

Living up to Life



# User Manual

Leica TCS SP8 SMD  
for FCS, FLIM and FLCS



Published by:

Leica Microsystems CMS GmbH  
Am Friedensplatz 3  
D-68165 Mannheim (Germany)

<http://www.leica-microsystems.com>  
<http://www.confocal-microscopy.com>

Responsible for contents:  
Leica Microsystems CMS GmbH

Copyright © Leica Microsystems CMS GmbH.  
All rights reserved.

This manual was created in cooperation with  
PicoQuant GmbH:

PicoQuant GmbH  
Rudower Chaussee 29  
12489 Berlin (Germany)

<http://www.picoquant.com>

## Copyright

All rights to this document are held by Leica Microsystems CMS GmbH. Adaptation, translation and reproduction of text or illustrations (in whole or in part) by print, photocopy, microfilm or other method (including electronic systems) is not allowed without express written permission from Leica Microsystems CMS GmbH.

Programs such as LAS and LAS AF are protected by copyright laws. All rights reserved. Reproduction, adaptation or translation of these programs is prohibited without prior written permission from Leica Microsystems CMS GmbH.

This User Manual specifies names of products or services that are trademarks or registered trademarks of the respective trademark owners. Rather than including a trademark (TM or ®) symbol at every occurrence of a trademarked name, we state that we are using the names only in an editorial fashion, and to the benefit of the trademark owner, with no intention of infringement.

Made in Germany.

© Copyright Leica Microsystems CMS GmbH.

All rights reserved.



# Contents

<b>Copyright</b> .....	<b>3</b>
<b>Contents</b> .....	<b>5</b>
<b>1 About this User Manual</b> .....	<b>15</b>
1.1 Additional Documentation .....	16
<b>2 Intended Use</b> .....	<b>17</b>
<b>3 Liability and Warranty</b> .....	<b>19</b>
3.1 Important Information for Operators and Users.....	19
<b>4 Meaning of the warning messages in the manual</b> .....	<b>21</b>
<b>5 General Safety Notes</b> .....	<b>23</b>
5.1 Commissioning and Use .....	23
5.2 Modifications to the System .....	24
5.3 Safety Devices and Safety Labels.....	24
5.4 Laser Safety .....	24
5.5 Electrical Safety .....	26
5.6 Contact with Liquids .....	26
5.7 Malfunction of the System .....	26
<b>6 Additional Notes on Handling the System</b> .....	<b>29</b>
6.1 Location.....	29
6.2 Using the Software .....	29
6.3 Protecting the System.....	30
6.3.1 Objectives .....	31
<b>7 System Overview and Properties</b> .....	<b>33</b>
7.1 TCS SP8 SMD System Variants .....	33
7.1.1 TCS SP8 SMD System Components .....	33
7.1.2 TCS SP8 SMD with Upright Microscope .....	34
7.1.3 TCS SP8 SMD with Inverted Microscope .....	34
7.2 TCS SP8 SMD System Variants with White Light Laser .....	35
7.2.1 TCS SP8 SMD System Components with White Light Laser.....	35
7.2.2 TCS SP8 SMD with White Light Laser and Upright Microscope .....	36
7.2.3 TCS SP8 SMD with White Light Laser and Inverted Microscope .....	37
7.3 TCS SP8 SMD System Variants with MP Configuration.....	38
7.4 Controls on the Supply Unit .....	40

7.4.1	Main Switch Board on the Flexible Supply Unit .....	40
7.4.2	Control Panel Field on the Compact Supply Unit (Only for FLIM) .....	40
7.5	Technical Data .....	41
7.5.1	Dimensions .....	41
7.5.2	Weight .....	41
7.5.3	Electrical Specifications .....	42
7.6	"Electromagnetic Compatibility" .....	42
7.7	Serial Number .....	43
<b>8</b>	<b>Ambient Conditions</b> .....	<b>45</b>
8.1	General Requirements Regarding Ambient Conditions .....	45
8.2	Vibrations .....	45
8.3	Room Dimensions .....	46
8.4	Electrical Connection Requirements .....	47
8.4.1	System with Flexible Supply Unit .....	47
8.4.2	System with Compact Supply Unit (Only with FLIM) .....	48
8.4.3	External Lasers .....	48
8.5	Load capacity of the multiple socket outlet on the flexible supply unit .....	49
8.6	Waste Heat and Cooling .....	49
8.6.1	System with Flexible Supply Unit .....	50
8.6.2	System with Compact Supply Unit (Only with FLIM) .....	50
8.6.3	External Lasers .....	50
<b>9</b>	<b>SMD Components</b> .....	<b>51</b>
9.1	Hardware Components and Software Licenses .....	51
9.1.1	FCS/FCCS Application Area .....	51
9.1.1.1	Special SMD Hardware .....	51
9.1.1.2	Software License .....	51
9.1.2	FLIM Application Area .....	52
9.1.2.1	Special SMD Hardware .....	52
9.1.2.2	Software License .....	52
9.1.3	Application area FCS/FCCS, FLIM, FLCS, gated FCS .....	53
9.1.3.1	Special SMD Hardware .....	53
9.1.3.2	Software License .....	53
9.2	Beam Path .....	53
9.3	Detection Units from PicoQuant .....	54
9.4	Leica APD Detector Unit .....	55
9.4.1	General Precautionary Measures for Using APD Detector Units .....	56
9.4.2	Changing the Fuse .....	56
9.4.3	Safety Shutoff .....	56

9.5	Trigger Unit	.56
9.6	Laser Coupling Unit (LCU)	.57
9.6.1	Attenuation Unit	.58
9.6.2	Other PicoQuant Components	.59
<b>10</b>	<b>Laser</b>	<b>.61</b>
10.1	Laser Classes	.61
10.2	Overview of Usable Lasers for Image Acquisition	.61
10.2.1	VIS/UV Lasers for TCS SP8	.61
10.2.2	VIS/UV Lasers for TCS SP8 X	.62
10.2.3	IR lasers for TCS SP8 MP	.62
10.2.3.1	Picosecond laser	.62
10.2.3.2	Femtosecond laser	.63
10.3	Overview of Usable Lasers for FCS	.63
10.3.1	VIS/UV Lasers for TCS SP8 SMD	.63
10.4	Overview of usable lasers for FLIM	.64
10.4.1	VIS/UV Lasers for TCS SP8 SMD	.64
10.4.2	Infrared Lasers for TCS SP8 SMD with MP Configuration	.64
10.4.2.1	Picosecond laser	.64
10.4.2.2	Femtosecond laser	.64
10.5	Overview of Usable Lasers for FLCS	.66
10.5.1	VIS/UV Lasers for TCS SP8 SMD	.66
<b>11</b>	<b>Safety Features</b>	<b>.67</b>
11.1	Main Circuit Breaker for Disconnecting the Power Supply	.67
11.1.1	Compact Supply Unit	.67
11.1.2	Flexible Supply Unit	.67
11.1.3	Other Components	.68
11.2	Key Switch	.68
11.2.1	Master Key Switch on the Compact Supply Unit	.68
11.2.2	Master Key Switch on the Flexible Supply Unit	.68
11.2.3	Key Switch for the White Light Laser	.69
11.2.4	Key Switch for UV Lasers	.69
11.2.5	Key Switches for Other External Lasers	.70
11.3	Emission Warning Indicators	.70
11.3.1	Emission Warning Indicator on the Supply Unit	.70
11.3.2	Emission Warning Indicator on the White Light Laser	.71
11.3.3	Emission Warning Indicator on UV Lasers	.71
11.3.4	Emission Warning Indicator on Other External Lasers	.72
11.3.5	Malfunction of Emission Warning Indicator	.72

11.4	Interlock Connectors	72
11.4.1	Interlock Connector on the Supply Unit	72
11.4.2	Interlock Connector on the White Light Laser	74
11.4.3	Interlock Connector on Other External Lasers	74
11.4.4	Interlock Connector on the Scan Head	75
11.5	Safety Switches on the Microscope	76
11.6	Warning Messages	76
11.7	Special Laser Safety Equipment	78
11.7.1	Laser Protection Tube and Laser Protection Shield	78
11.7.2	Safety Beam Guide on the MP System	79
<b>12</b>	<b>Safety Labels on the System</b>	<b>81</b>
12.1	Compact Supply Unit (Only for FLIM)	81
12.2	Flexible Supply Unit	82
12.3	Inverted Microscope	83
12.4	Upright Microscope	84
12.5	Mirror Housing	85
12.6	Cover for Replacement Flange	86
12.7	Transmitted Light Detector (TLD)/Reflected Light Detector (RLD)	87
12.8	Scan Head	87
12.9	White Light Laser	89
12.10	External UV Laser	89
12.11	MP Beam Coupling Unit	90
12.12	Other External Lasers	90
<b>13</b>	<b>Switching On the System</b>	<b>91</b>
13.1	Confocal System with Flexible Supply Unit	91
13.2	Confocal System with Compact Supply Unit (Only with FLIM)	96
13.3	HyD Reflected Light Detectors (HyD RLDs)	99
13.4	Starting the SMD Hardware and Software	100
<b>14</b>	<b>LAS AF</b>	<b>103</b>
14.1	Starting LAS AF	103
14.2	Structure of the Graphical User Interface	104
14.3	Design of the FLIM Wizard in LAS AF	107
14.4	Design of the FCS Wizard in LAS AF	110
14.5	LAS AF Online Help	113
14.5.1	Structure of Online Help	113
14.5.2	Accessing Online Help	113

14.5.3	Selecting the Language for Online Help	113
14.5.4	Using Online Help	114
14.5.5	Full-text Search with Logically Connected Search Terms	115
<b>15</b>	<b>Selecting the Laser</b>	<b>117</b>
15.1	Activate laser as the excitation source in the configuration menu	117
15.1.1	Using Continuous Wave VIS Lasers	118
15.1.2	Using MP lasers	119
15.1.3	Using Pulsed VIS Lasers	121
15.1.4	Using Pulsed UV Lasers	124
15.1.5	Using a Pulsed White Light Laser	124
<b>16</b>	<b>FLIM Data Acquisition</b>	<b>127</b>
16.1	Setup Imaging Step – Image Acquisition	127
16.1.1	Selecting Detectors for the Image Acquisition	127
16.1.1.1	Internal Photomultipliers (Including SP FLIM PMT)	127
16.1.1.2	External APDs	129
16.1.1.3	External FLIM Photomultiplier	130
16.1.2	Selecting Laser Lines as an Excitation Source for Image Acquisition	130
16.1.2.1	Using Continuous Wave Lasers	130
16.1.2.2	Using MP Lasers	131
16.1.2.3	Using Pulsed VIS Lasers	131
16.1.2.4	Using Pulsed UV Lasers	132
16.1.2.5	Using White Light Lasers	133
16.1.3	Adjusting the Pinhole for Image Acquisition	133
16.2	Setup FLIM Step – Optimizing the FLIM Measurement Conditions	134
16.2.1	Selecting FLIM Detectors	134
16.2.1.1	FLIM Data Acquisition with Internal SP FLIM Detectors	135
16.2.1.2	FLIM Data Acquisition with External MPD APDs	136
16.2.1.3	FLIM Data Acquisition with External Photomultiplier	137
16.2.1.4	FLIM Data Acquisition with Detectors at NDD Position (HyD RLD)	138
16.2.2	Selecting Laser Lines for FLIM	140
16.2.2.1	Do Not Use Continuous Wave VIS Lasers	140
16.2.2.2	Using Pulsed Diode Lasers (UV, VIS)	141
16.2.2.3	Using MP Lasers	141
16.2.2.4	Using White Light Lasers	142
16.2.3	Adjusting the Fluorifier Disc	142
16.2.3.1	Setting for SP FLIM	142
16.2.3.2	Setting for External FLIM or Intensity Image Acquisition	144
16.2.3.3	Setting for FLIM White Light Laser	144

16.2.4	Changing the Pulse Frequency for Pulsed Diode Lasers (405, 440, 470, 640 nm) .....	145
16.2.5	2-Laser PIE (405, 470, 640 nm) .....	146
16.2.6	Changing Pulse Frequency for White Light Lasers .....	147
16.2.7	Setting the Pinhole .....	148
16.2.8	Optimizing FLIM Settings .....	148
16.2.9	Count Rate Monitor .....	149
16.2.10	Loading and Saving FLIM-specific Instrument Parameter Settings .....	149
16.3	Measurements Step – Time Series for FLIM Measurement at Multiple Points .....	150
16.3.1	FLIM Network Connection .....	150
16.3.2	Definition of the FLIM Measurement File Names Transferred to SymPhoTime .....	150
16.3.3	Defining a Single FLIM Image .....	152
16.3.4	Defining an xyz or xzy FLIM Stack .....	153
16.3.5	Defining an FLIM Time Series .....	154
16.3.6	Defining a Time Series of xyz or xzy FLIM Stacks .....	155
16.3.7	Defining an xy or xz FLIM Stack .....	157
16.3.8	Defining a Time Series of xy or xz FLIM Stacks .....	158
16.3.9	Defining an xy or xz FLIM Stack .....	160
16.3.10	Control of FLIM Measurements .....	162
<b>17</b>	<b>Summarized Manual for FLIM Experiments .....</b>	<b>163</b>
17.1	Prerequisites .....	163
17.2	Selecting Position for the FLIM Measurement .....	163
17.3	Changing from Continuous to Pulsed Excitation .....	163
17.4	Changing from Internal Detection on the SP8 to External TCSPC Detectors .....	164
17.5	Using Internal SP FLIM Detection .....	164
17.6	Using FLIM Detectors at the NDD Position (HyD RLD) .....	164
17.7	Setting Suitable Scan Parameters .....	165
17.8	Optimizing the Photon Count Rate .....	165
17.9	Selecting the Correct Laser Repetition Rate .....	168
17.10	Starting FLIM Data Acquisition .....	170
17.11	Resulting Raw Data File and Documentation .....	170
17.12	Measuring the Instrument Response Function (IRF) .....	172
17.12.1	Preparing IRF Measurements .....	172
17.12.1.1	Estimating the IRF .....	172
17.12.1.2	With Reflection Mode .....	172
17.12.1.3	With Fluorescence Mode .....	173
17.12.1.4	With SHG (Second Harmonic Generation – Possible for MP Lasers Only) .....	173

17.12.2	Running IRF Measurement	174
17.13	Remarks	176
17.13.1	Ad-hoc-Inspection of a Specimen	176
17.13.2	Bidirectional Scanning	176
17.13.3	Setting the Laser Intensity of the Diode Lasers	176
17.13.4	Sensitivity of the Fluorescence Detection	176
17.13.5	Optimum Lifetime Information	176
<b>18</b>	<b>F(L)CS Data Acquisition</b>	<b>177</b>
18.1	Preparing the FCS Measurement	177
18.1.1	Selecting an Objective	177
18.1.2	Calibrating the Positioning Accuracy of the FCS Measuring Point	177
18.1.3	Testing the Positioning Accuracy	181
18.1.4	Adjusting the Correction Ring on the Objective	183
18.1.5	Setting the Reference Position	186
18.1.6	Acquiring a Reference Image	186
18.1.6.1	Image Acquisition Using Photomultipliers	187
18.1.6.2	Image Acquisition with PE APDs (AQR Type) or MPD APDs (PDM Type)	188
18.2	Setup Imaging Step – Image Acquisition	190
18.2.1	Selecting Detectors for the Image Acquisition	190
18.2.1.1	Photomultiplier (PMT) / Internal Hybrid Detector (HyD)	190
18.2.1.2	PE / MPD APDs	190
18.2.2	Selecting Laser Lines as an Excitation Source for the Image Acquisition	191
18.2.2.1	Using Continuous Wave Lasers	191
18.2.2.2	Using MP Lasers	192
18.2.2.3	Using Pulsed VIS Lasers	192
18.2.2.4	Using a Pulsed UV Laser	193
18.2.2.5	Using White Light Lasers	194
18.2.3	Adjusting the Pinhole for Image Acquisition	194
18.3	Setup FCS Step – Optimizing FCS Measurement Conditions	195
18.3.1	Selecting APDs	195
18.3.2	Selecting Laser Lines for FCS	195
18.3.2.1	Using Continuous Wave VIS Lasers	195
18.3.2.2	Using Pulsed VIS Diode Lasers	196
18.3.2.3	Using White Light Lasers	197
18.3.3	Fluorifier Disc	197
18.3.4	Setting the Pinhole	197
18.3.5	Optimizing FCS Settings	198
18.3.6	Count Rate Monitor	199
18.3.7	Loading and Saving FCS-specific Instrument Parameter Settings	200

18.4	Measurements Step – FCS Measurement Time Series at Multiple Points . . . . .	201
18.4.1	FCS Network Connection . . . . .	201
18.4.2	Definition of Multiple FCS Measuring Points in an Image or Stack. . . . .	202
18.4.3	FCS Time Series at Multiple Measuring Points. . . . .	204
18.4.4	Definition of the File Names Transferred to SymPhoTime during the FCS Measurement . . . . .	206
18.4.5	FCS z-Stack . . . . .	207
18.4.6	Operating the FCS Measurement Series . . . . .	208
<b>19</b>	<b>Summarized manual for FCS or other point measurements . . . . .</b>	<b>209</b>
19.1	Prerequisites. . . . .	209
19.1.1	Choosing the Location for the FCS Measurement . . . . .	209
19.2	Starting Point/ FCS Data Acquisition . . . . .	210
<b>20</b>	<b>Changing the Specimen . . . . .</b>	<b>213</b>
20.1	Changing the Specimen on an Upright Microscope . . . . .	213
20.2	Changing the Specimen on an Inverted Microscope . . . . .	213
<b>21</b>	<b>Changing the Objective . . . . .</b>	<b>215</b>
<b>22</b>	<b>Piezo Focus on Upright Microscope . . . . .</b>	<b>217</b>
<b>23</b>	<b>Changing the Filter Cube . . . . .</b>	<b>219</b>
<b>24</b>	<b>Changing Detector Cable Connections on the Scan Head and Router When Using HyD-RLD. . . . .</b>	<b>221</b>
24.1	Hardware Trees . . . . .	222
24.1.1	MP on FCS FLIM 2 APD . . . . .	223
24.1.2	MP off FCS FLIM 2 APD . . . . .	223
24.1.3	MP on HyD RLD FLIM . . . . .	223
24.2	Connect and Use Detectors . . . . .	224
24.2.1	Using SP FLIM PMT . . . . .	224
24.2.2	Using MPD APDs . . . . .	224
24.2.3	Using HyD-RLD . . . . .	225
<b>25</b>	<b>Switching Off the System . . . . .</b>	<b>229</b>
25.1	System with Flexible Supply Unit . . . . .	229
25.2	System with Compact Supply Unit (Only for FLIM). . . . .	233
<b>26</b>	<b>Care and Cleaning . . . . .</b>	<b>239</b>
26.1	Cleaning Surfaces . . . . .	239
26.2	Cleaning the Optical System . . . . .	239
26.3	Cleaning Immersion Lenses . . . . .	240

---

26.4 Care .....	240
<b>27 Repairs and Service Work.....</b>	<b>241</b>
<b>28 Maintenance .....</b>	<b>243</b>
28.1 Having Coolant Replaced .....	243
<b>29 Disassembly and Transport.....</b>	<b>245</b>
<b>30 Disposal .....</b>	<b>247</b>
<b>31 Troubleshooting.....</b>	<b>249</b>
31.1 Hardware Configuration Gets Lost or Software Needs to be Installed Again. .	249
31.2 The Instrument Is Losing Sensitivity.....	249
31.2.1 Causes for Decreased Performance .....	250
31.3 No FLIM Image is Displayed During Measurement.....	250
31.4 How to Handle PQ Error Codes in LAS AF .....	252
<b>32 Contact .....</b>	<b>253</b>
<b>33 Recommended literature .....</b>	<b>255</b>
<b>34 Abbreviations.....</b>	<b>257</b>
<b>35 Appendix.....</b>	<b>259</b>
35.1 Patents.....	259
35.2 Safety Data Sheets from Third-Party Manufacturers .....	259
35.3 Compliance .....	265
35.4 People's Republic of China.....	267



# 1 About this User Manual

Prior to commissioning the system, carefully read through this User Manual and be absolutely certain to follow the safety notes contained in it. So that you can operate the system safely and react quickly and correctly in the event of an emergency, you must familiarize yourself with the safety devices before using it for the first time. In this case, read **Chapter "Safety Features"** in this manual. Keep this User Manual and the included manuals for the microscope and other components in a safe place easily accessible for all users.

This Manual gives you important information about safe handling of the system. All information is intended for the safety of users and trouble-free operation of the system. Unless the information pertains specifically to certain system variants, the instructions always apply to the basic system described here.

This User Manual provides you with important information for using the system, the necessary ambient conditions and the usable lasers. It explains system startup. The system is assembled and disassembled by service technicians that have been authorized by Leica Microsystems CMS GmbH. This is why unpacking, assembly and installation of the system are not described in this manual. You can find an overview of the system and specifications in the **Chapter "System Overview and Properties"**. For information about special configurations, such as optional lasers or specific objectives, refer to the respective included manual. In **Chapter 34** you will find a list of abbreviations used in this manual.

This operating manual was created by PicoQuant GmbH and Leica Microsystems CMS GmbH and is concentrated on specialized knowledge about SMD (Single Molecule Detection). The basic procedures for acquiring FLIM images and point measurements for FCS using the TCS SMD system are described here.

This User Manual does not contain any information about basic optical principles or the operating principle of microscopes, confocal systems and the like. If you are interested in these topics or certain applications from the area of optics and confocal microscopy, you can read more about them at the Leica Microsystems CMS GmbH knowledge portal: <http://www.leica-microsystems.com/science-lab/>

The system is delivered with the latest version of the licensed "Leica Application Suite Advanced Fluorescence" (LAS AF) software. Within the Leica LAS AF software, FCS and FLIM experiments are designed and executed using special wizards. After data acquisition, the SMD data analysis is carried out within the "SymPhoTime" (SPT) software by PicoQuant. Read **Chapter "LAS AF"** in this User Manual in order to familiarize yourself with the design and basic operation of the software. Additional information about specific functions can be found in the online help.

The instructions contained in this documentation reflect state-of-the-art technology and knowledge standards at the time of publication. Leica Microsystems CMS GmbH reserves the right to revise this documentation and/or to further develop and improve the products described in this document at any time without prior notice or any other obligation.

If you have any suggestions or improvements for this User Manual, please contact the Leica branch office in your country.

## 1.1 Additional Documentation

The system is delivered with additional manuals. These manuals contain detailed information about the hardware components and the software-based analysis that absolutely must be observed. Manuals for the following components are provided with the system:

- **Detection unit:** This manual varies depending on the detection system. Here you can find basic information about alignment of the detection path and how to change filters. No separate manual is provided for the Leica APD detection unit. This detection unit is described in this User Manual in **Chapter 9.4**.
- **PicoHarp 300:** Provides all information about the TCSPC (Time Correlated Single Photon Counting) unit. This manual also includes an introduction about single photon counting.
- **Light sources:** The green folder contains detailed information about the features of your pulsed diode laser.
- **Router (PHR800):** The router is required in systems with multiple detectors.
- **Laser driver (PDL):** The manual for the laser driver varies depending on the laser driver used and includes information for configuring different intensities.
- **Software (SymPhoTime):** Contains all information about the software, including data acquisition and analysis. The SymPhoTime software also contains a detailed help function, which can be accessed by pressing the F1 button.

Aside from this, there is one more important document that must be observed:

- **System specifications:** The System Specifications appendix contains information about your specific FLIM/FCS system, including a description of the included parts, information about filter handling, and a wiring diagram that enables you to restore the configuration more easily after disassembly.

## 2 Intended Use

This system is intended for use in a lab. The system was designed for confocal scanning (laser scanning images) of fluorescence-marked living and fixed specimens as well as for quantitative measurements in the area of life science.

Applications of in-vitro diagnostics in accordance with MPG (German Medical Devices Act) are excluded from proper intended use.

This system must not be used together with life-support systems such as those found in intensive-care wards.

The owner/operator and user of this product are responsible for proper and safe operation and safe maintenance of the system and for following all applicable safety regulations. The owner/operator and user are fully liable for all consequences resulting from the use of the system for any purposes other than those listed in the User Manual or the online help.

The manufacturer assumes no liability for damage caused by, or any risks arising from, use of the microscopes for purposes other than those for which they are intended, or not using the microscopes within the specifications of Leica Microsystems CMS GmbH. In such cases, the Declaration of Conformity shall be invalid.



## 3 Liability and Warranty

Leica Microsystems CMS GmbH shall not be liable for damages resulting from failure to observe the information in this User Manual. The information here does not in any way modify the warranty and liability clauses contained in the general terms and conditions of Leica Microsystems CMS GmbH.

Repairs and servicing may be performed only by service technicians authorized by Leica Microsystems CMS GmbH. Opening or working on the system in any way shall void any and all warranty claims.

The manufacturer assumes no liability for damage caused by, or any risks arising from, use of the microscopes for purposes other than those for which they are intended, or not using the microscopes within the specifications of Leica Microsystems CMS GmbH. In such cases, the Declaration of Conformity shall be invalid.

Leica Microsystems CMS GmbH shall not be liable for any damage caused by incorrect storage, improper transport or an unsuitable installation location.

Figures are for illustration purposes. The system you purchased can deviate from the illustrations without Leica Microsystems CMS GmbH explicitly specifying such.

Leica Microsystems CMS GmbH shall not be liable for any injury or property damage caused by untrained or unauthorized persons.

### 3.1 Important Information for Operators and Users

- The owner/operator is required to designate a Laser Safety Officer or a Laser Protection Advisor according to the applicable legal requirements in each country.
- The owner/operator and user of this product are responsible for proper and safe operation and safe maintenance of the system and for following all applicable safety regulations.
- The owner/operator and user are fully liable for all consequences resulting from the use of the system for any purposes other than those listed in the User Manual or the online help.
- The owner/operator and user are obligated to perform and monitor suitable safety measures (according to national regulations).
- The owner/operator and user are responsible for observing the laser safety regulations according to applicable country-specific regulations.
- The owner/operator and user must ensure that this laser product is commissioned and operated only by persons who have been trained in the use of the system and the potential dangers of laser radiation.
- The owner/operator and user are fully liable for all consequences resulting from the use of the system if it is opened, improperly serviced or repaired by persons other than authorized Leica service representatives.



## 4 Meaning of the warning messages in the manual

**WARNING Electric shock**



This warns you of hazardous electrical voltage. Following the instructions is mandatory, since otherwise there is a risk of severe or fatal injury.

**WARNING Severe injuries from ...**



This note warns you of hazards that can cause severe or fatal injuries.

**WARNING Permanent eye and skin damage from laser radiation**



This note warns you of eye and skin damage that can occur when using lasers if safety precautions are not taken.

**WARNING Risk of injuries due to harmful or irritating substances**



This note warns you of substances that pose a health hazard.

**WARNING Risk of injuries due to biological substances**



This note warns you of biological substances that pose a health hazard.

**WARNING Risk of burns on hot surfaces**



This note warns you of hot surfaces that can cause burns.

**CAUTION**    **Injuries from...**



This note warns you of minor to moderate injuries that can be prevented by following instructions.

**NOTICE**    **Risk of damage to the system**

This note describes possible material damage that can occur in case of misuse.

**NOTICE**    **Loss of data**



This note warns you of the potential for losing data.



**Observe user manual**

This mandatory sign indicates that an additional user manual must be followed.



**Wear laser safety glasses**

This mandatory sign indicates that laser safety glasses must be worn to prevent eye injuries.



**Additional note**

This note serves to emphasize important instructions for handling the product or contains special instructions about a certain topic.

## 5 General Safety Notes

You have to follow the instructions listed below to work with the instrument safely and without disturbance. If you do not follow these or other instructions in this User Manual or the included manual, Leica Microsystems CMS GmbH shall not be liable for any resulting injury or property damage.

As it is impossible to anticipate every potential hazard, please be careful and apply common sense when using the system.

### 5.1 Commissioning and Use

- The system components have been packaged securely for transport in multiple crates. Do not open these crates. The crates may be opened and unpacked by Leica service technicians or by people who are authorized by Leica Microsystems CMS GmbH only.
- The system may only be set up by Leica service technicians or by people who are authorized by Leica Microsystems CMS GmbH.
- This laser equipment may be operated only by persons who have been trained in the use of the system and about the potential hazards of laser radiation.
- Have your laser safety officer instruct you about the dangers of laser radiation and about suitable laser safety precautions, such as wearing suitable laser safety glasses. This applies to all persons present in the room where the system is set up and operated.
- Each user must have read the instructions included and follow the instructions it contains.
- Specimens must always be securely fixed in place.
- Do not introduce any flammable objects, such as paper, into the specimen area when you are working with a laser.
- Do not place any flammable or combustible objects on or near the system and do not put it near hot surfaces.
- During start up and during operation, you have to keep your hands and fingers away from the specimen area, as otherwise there is a risk of crushing hazards or injury from rotating objectives and the motorized specimen stage.
- Set up the workplace (for example, chair and monitor) on the system so that it corresponds to your requirements. Observe the national regulations for occupational safety.
- Before each service call by a service technician or whenever you relocate the instrument, you have to clean it thoroughly. This is necessary to remove any possible contamination, thereby preventing the transfer of dangerous substances and pathogens and avoiding hazards and dangers. The same also applies to the removal of components. This applies in particular to systems that are located in biomedical research labs.
- You must not deviate from the operating and maintenance instructions provided herein.

## 5.2 Modifications to the System

- The system is installed by service technicians from Leica Microsystems CMS GmbH. You must not change the position of the system components.
- The supply unit must always be set up and operated in an upright position.
- Under no circumstances may you open housing parts.
- Never disconnect a fiber optic cable.
- The cable and fiber optic cable may not be folded, stretched, pinched or rolled up tightly or damaged in any other way.
- The product has a closed liquid coolant circuit. The cooling liquid hoses may not be folded, stretched, pinched or rolled up tightly or damaged in any other way.
- Do not connect any external equipment or other components. If you have questions, please directly contact the Leica branch office in your country.

## 5.3 Safety Devices and Safety Labels

- So that you can operate the system safely and react quickly and correctly in the event of an emergency, you must familiarize yourself with the safety devices before using it for the first time. Read **Chapter "Safety Features"** of this User Manual carefully.
- Never remove the safety devices on the system.
- Never deactivate the laser protection devices.
- All safety devices must be ready to operate. Do not carry out any procedures that modify, disable or damage the functionality of safety features. Unauthorized procedures could result in serious injuries or property damage.
- Safety labels on the system may not be removed. Missing or damaged safety labels must be attached immediately and at the described location. Observe **Chapter "Safety Labels on the System"**.

## 5.4 Laser Safety

- The instrument is a Class 3B/IIIb (VIS and UV lasers) or a Class 4/IV (IR lasers) laser product.
- You must observe all suitable safety measures applicable for this laser class.
- When using an MP system, you must wear laser safety glasses (Order No.: 158002570). Appropriate laser safety glasses for IR laser radiation are provided with the system when delivered. During the scanning operation, all persons present in the room must wear such laser safety glasses. These laser safety glasses do not provide any protection against visible laser radiation (visible spectrum)!
- It is not necessary to wear protective eyewear when using VIS and UV lasers. When used as intended and safety notes have been followed, laser radiation is kept within the limit value that eliminates the chance for eye injuries.
- Never look directly into a laser beam or a reflection of the laser beam. Avoid all contact with the laser beam.

- Never expose your eyes or skin to direct or indirect laser radiation. The radiation can cause irreparable eye and skin injuries.
- During the scanning operation, the laser radiation is accessible in the microscope's specimen area without obstruction after coming out of the objective. Always maintain a nominal ocular hazard distance of at least 20 cm (8") between your eyes and the opening of the objective.

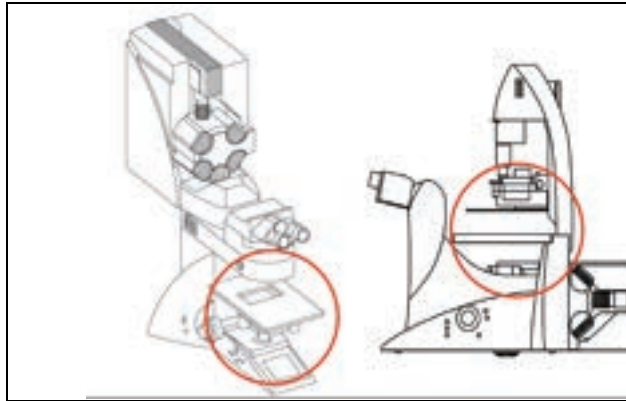

**Figure 1: Specimen area of upright and inverted microscope**

- Make sure that the fiber optic cables are not damaged. The system may not be turned on with damaged fiber optic cables, as laser radiation can escape and lead to irreparable eye and skin injuries.
- It is not necessary to wear protective eyewear when using VIS and UV systems. When used as intended and safety notes have been followed, laser radiation is kept within the limit value that eliminates the chance for eye injuries.
- Do not use an S70 microscope condenser. The large working distance and the low numerical aperture of the S70 microscope condenser could result in a hazard from laser radiation.
- Only use S1 and S28 Leica microscope condensers.
- Do not look into the eyepieces during the scanning operation.
- Never change samples during a scanning operation.
- Never change objectives, filter cubes, beam splitters, condensers or other components during a scanning operation.
- Do not look into the eyepieces when switching the beam path in the microscope.
- Do not introduce any reflective objects or mirrors into the laser beam path or into the specimen area.
- If there is no lamp housing or mirror housing connected to the microscope, attach the cover to the replacement flange.
- All unoccupied positions in the objective nosepiece must be closed using the supplied caps.
- For MP systems, dry objectives (air objectives) may not be used with a numerical aperture (NA) larger than 0.85. This does not apply to immersion objectives (oil, water).

## 5.5 Electrical Safety

- This system is designed for connection to grounded (earthed) outlets. The grounding plug performs an important safety function. To avoid the risk of electrical shock or damage to the instrument, do not disable this feature. Operation without grounded sockets is not permitted.
- Make sure that the supply voltage at the system remains in an approved tolerance range (100 V~ - 240 V~  $\pm 10\%$ ).
- The system may be connected to a power supply with ground protection conductor only! Do not interfere with the grounding function by using an extension cord without a ground wire. Any interruption of the ground wire inside or outside of the system, or release of the ground wire connection, can cause the system to become hazardous. Intentionally disconnecting the ground protection conductor is not permitted.
- Before any cleaning or servicing, de-energize the entire system. To do so, use the power switches of all components and disconnect all power cables from the power supply.
- Only use the power cable included or provided by your local Leica service technicians for connecting individual peripheral devices to the power supply.
- Fuses inside the system may be replaced only by authorized Leica service employees. If you have any further questions, please directly contact the Leica branch office in your country.
- Check that the actual line voltage corresponds to the value configured on the PDL-800-B or D laser driver.

## 5.6 Contact with Liquids

- To avoid the risk of electrical shock and fire hazards, never expose the system to rain or moisture.
- Do not allow any liquid to enter the system housing or come into contact with any electrical components.
- Avoid condensation.
- The system must be completely dry before connecting it to the power supply or turning it on.
- Do not operate the system if coolant is leaking or has leaked.

## 5.7 Malfunction of the System

You must immediately disconnect the system from the power supply if any of the following occur:

- The emission warning indicator is not lit after being switched on using the detachable-key switch.
- The indicator continues to be lit after being switched off using the keyswitch
- Scanning of the specimen is not activated after being switched on properly (laser radiation in the specimen area).

If any of these occur, immediately notify the Leica branch office in your country or your local contact person.



## 6 Additional Notes on Handling the System

Follow these instructions to ensure that you handle the system without interference to avoid damage to the instrument and loss of data.

### 6.1 Location

- You need sufficient space for temporary storage and for unpacking the delivered components. Always protect the transport crates and their contents from moisture and condensation and store them facing upwards (see the indication on the crate).
- Upon receiving the crates, make sure they are intact. If you find that the crates or seals have been damaged, have the supplier confirm this; inform your contact person at Leica Microsystems about this immediately.
- Keep the packaging material in case you need to return a defective component.
- Be absolutely certain to observe the ambient conditions applicable for this system.
- You may use the system indoors only.
- The room must be free of dust, oil and chemical vapors.
- After installing the system, you may carry out interior finish work on the room only if the system is stored in a dust-free location while this work is underway.
- Avoid direct sunlight and vibrations, since these can distort measurements and micrographic scans.
- We recommend using a room that can be completely darkened.
- Do not expose the system to drafts.
- If the system has to be moved to a new location for any reason, contact the Leica branch office in your country.

### 6.2 Using the Software

- Before carrying out operating steps with the system, first read the corresponding description of the function in LAS AF Online Help. For an overview of the individual functions, refer to the table of contents of the online help.
- Back up your data regularly to a suitable data carrier.
- Do not install any hardware or software on the workstation, as otherwise serious damage to the system or loss of data can result.

- Do not switch the workstation off after a software crash, but restart the LAS AF software after 15 seconds. No image data are lost in case of a software crash. If the LAS AF software is restarted without restarting the workstation, the data are automatically restored. If the software crash is caused by a crash of the workstation, the image data will be lost.

## 6.3 Protecting the System

- Observe the maintenance instructions and intervals prescribed in the **Chapter "Maintenance"**.
- During the update of the firmware, a continuous tone sounds. After the updated component is automatically restarted, the signal stops. During the automatic update and the automatic restart of the component, you may not switch off or restart the system, since otherwise this can lead to damage to the system.
- Protect the system from dust and grease.
- Make sure to use only one small drop of immersion fluid. The immersion fluid may not contaminate or enter the microscope.
- Make sure that the specimen carrier is not against the objective and cannot be damaged by it or cause broken glass.
- Be absolutely certain to prevent the optics and mechanical parts from coming into direct contact with acids, bases and other aggressive chemicals.
- Never use abrasive products to clean the system and its components. Abrasives can scratch the surface and thus have a negative effect on the protection of the parts.
- Protect the microscope from excessive temperature fluctuations. Such fluctuations can lead to the accumulation of condensation, which can damage the electrical and optical components.
- Allow the entire system to cool down to room temperature before covering the system with a dust cover. This prevents condensation from forming below it, which can enter the system and damage it.
- When used as intended, the HyD reflected light detectors are sufficiently protected from destruction due to overexposure by measures in LAS AF and by an electronic protective circuit. An audible signal (beep) warns the user if the detector is being operated near the maximum permitted signal level. If the maximum permitted signal level is exceeded, the detector automatically switches off and the red status LED on the detector module (see **Chapter 13.3, Figure 81, item 2**) lights up.
- APDs are extremely sensitive detectors which can be damaged irreparably by light that is too intense (such as room lighting). For this reason, APDs are protected by an automatic shut-off. If the light that falls on the APDs is too intense, they are switched off for a few seconds and an audible warning signal is emitted. The APDs are automatically reactivated after a few seconds. Either switch off the APDs or reduce the light intensity (e.g. by reducing the light intensity of the laser).
- To protect the counting units, never connect or disconnect any cable while the data acquisition and control electronics are activated. Charged signal cables can destroy the instruments.
- Protect the photodetectors (APD or photomultiplier), particularly from excessive light intensity, such as that from the microscope illumination, unattenuated backscatter

excitation etc.

- If you have any further questions, please directly contact the Leica branch office in your country (see **Chapter "Contact"**).

### **6.3.1 Objectives**

- Only use immersion fluids that are intended for the objective. Unsuitable immersion fluid can contaminate or destroy the objective.
- When changing over from an oil or water objective to a dry objective, you have to remove the immersion medium from the specimen slide in order not to damage the dry objective.
- Never open the objectives for cleaning.
- If there is a piezo focus installed on your system, be absolutely certain to observe the corresponding notes in **Chapter "Piezo Focus on Upright Microscope"**.



## 7 System Overview and Properties

### 7.1 TCS SP8 SMD System Variants

#### 7.1.1 TCS SP8 SMD System Components

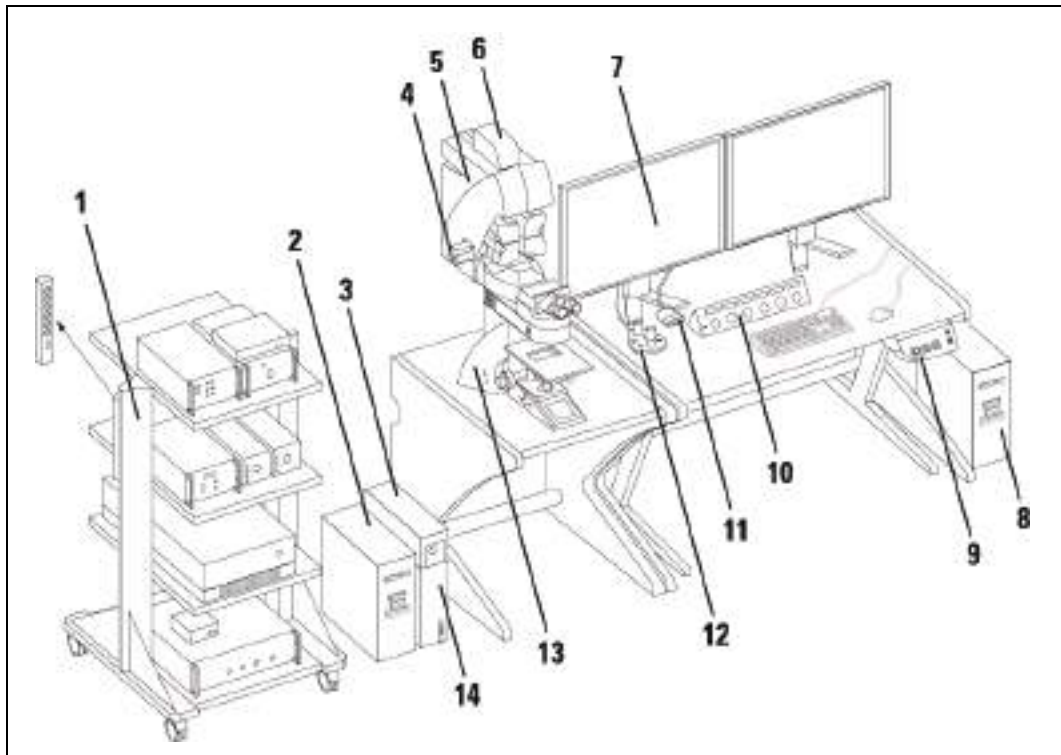

**Figure 2:** System components using the TCS SP8 SMD with upright microscope and flexible supply unit as an example

- |   |  |
|---|--|
| 1 Trolley with external lasers, detectors and their controllers | 8 TCS SP8 workstation                    |
| 2 SMD workstation   | 9 Main switch board on the supply unit   |
| 3 Fluorescence lamp EL6000                                      | 10 Control panel                         |
| 4 Multifunction port (MFP) on the scan head                     | 11 KVM switch                            |
| 5 Scan head   | 12 SmartMove (only with motorized table) |
| 6 X1 port on the scan head                                      | 13 Upright microscope                    |
| 7 Monitors  | 14 Microscope electronics box            |

### 7.1.2 TCS SP8 SMD with Upright Microscope

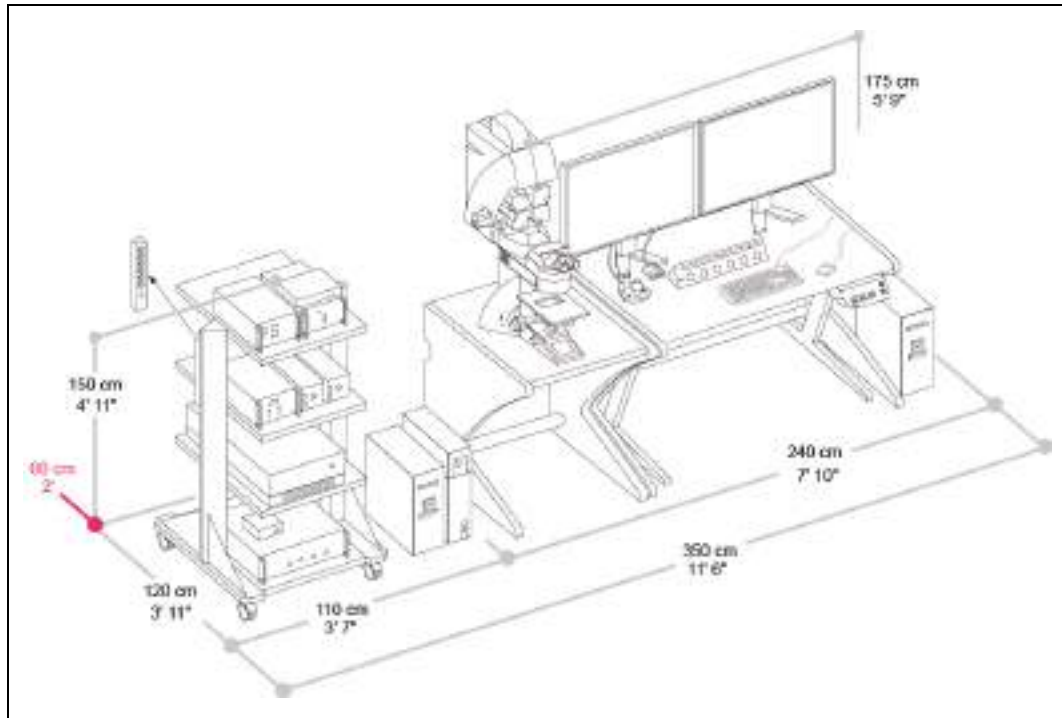

Figure 3: Dimensions of TCS SP8 SMD with upright microscope and flexible supply unit

### 7.1.3 TCS SP8 SMD with Inverted Microscope

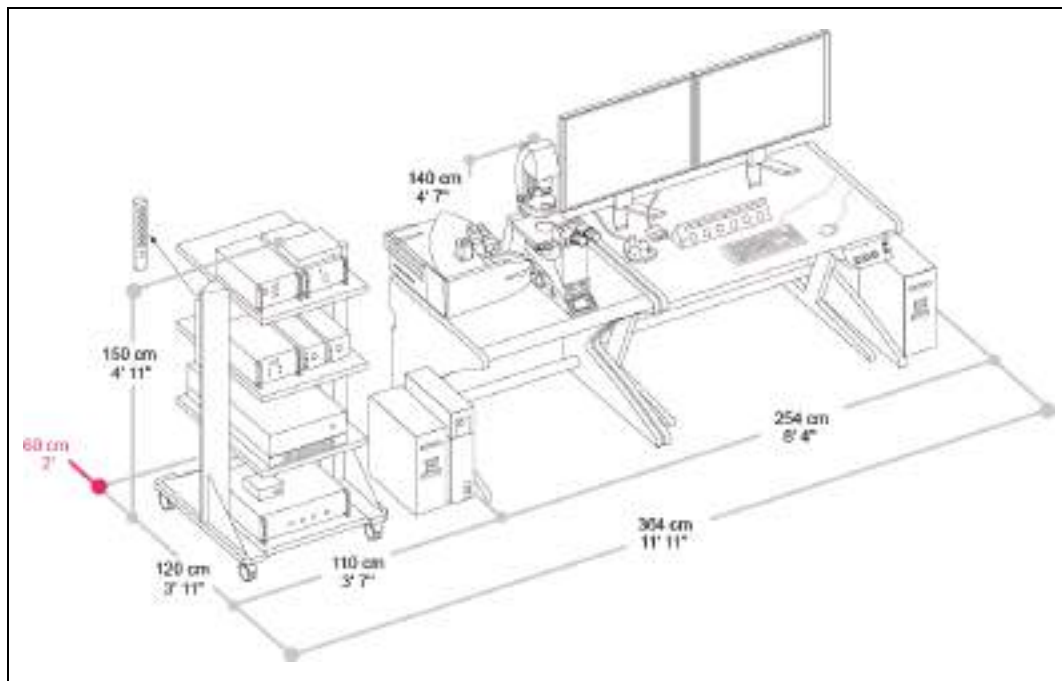
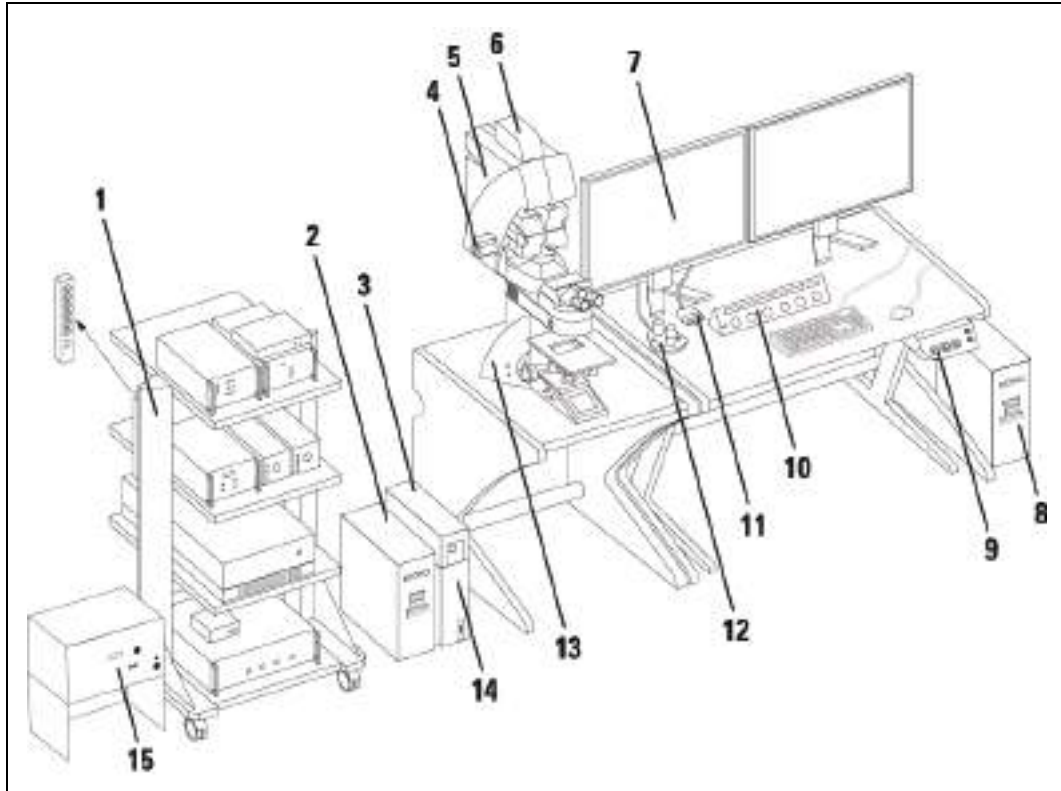

Figure 4: TCS SP8 SMD dimensions with inverted microscope and flexible supply unit

## 7.2 TCS SP8 SMD System Variants with White Light Laser

### 7.2.1 TCS SP8 SMD System Components with White Light Laser



**Figure 5:** System components using the TCS SP8 SMD with white light laser, upright microscope and PicoQuant laser as an example

- |   |  |
|---|--|
| 1 Trolley with external lasers, detectors and their controllers | 8 TCS SP8 workstation                    |
| 2 SMD workstation   | 9 Main switch board on the supply unit   |
| 3 Fluorescence lamp EL6000                                      | 10 Control panel                         |
| 4 Multifunction port (MFP) on the scan head                     | 11 KVM switch                            |
| 5 Scan head   | 12 SmartMove (only with motorized table) |
| 6 X1 port on the scan head                                      | 13 Upright microscope                    |
| 7 Monitors  | 14 Microscope electronics box            |
|   | 15 White light laser                     |

## 7.2.2 TCS SP8 SMD with White Light Laser and Upright Microscope

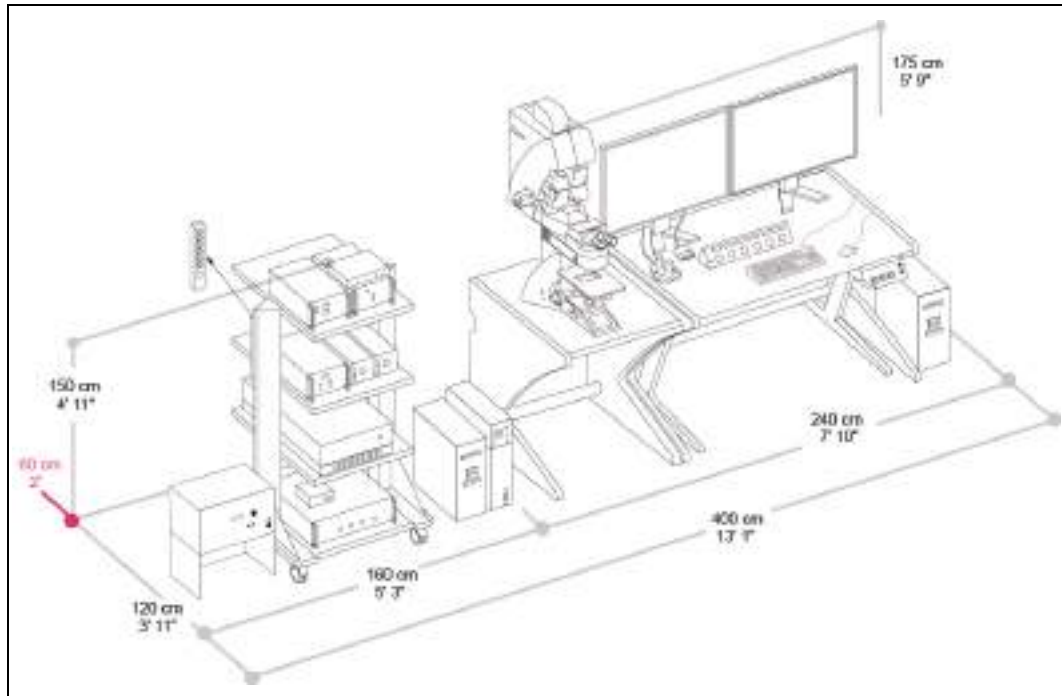

Figure 6: Dimensions of TCS SP8 SMD with white light laser, upright microscope, and PicoQuant laser

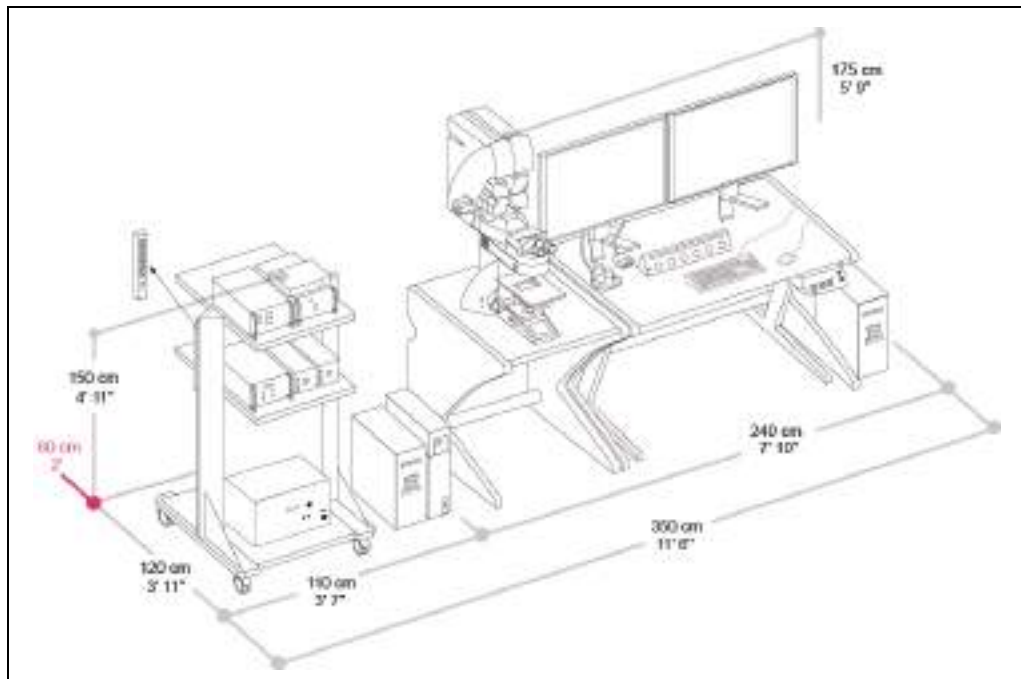

Figure 7: Dimensions of TCS SP8 SMD with white light laser and upright microscope, without PicoQuant laser

### 7.2.3 TCS SP8 SMD with White Light Laser and Inverted Microscope

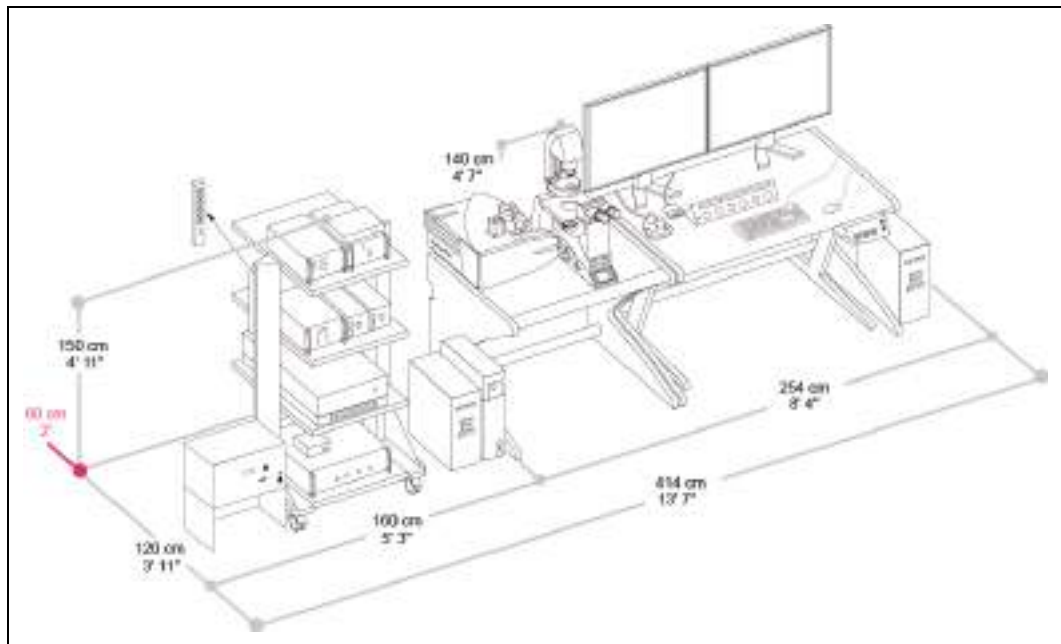

Figure 8: Dimensions of TCS SP8 SMD with white light laser, inverted microscope and PicoQuant laser

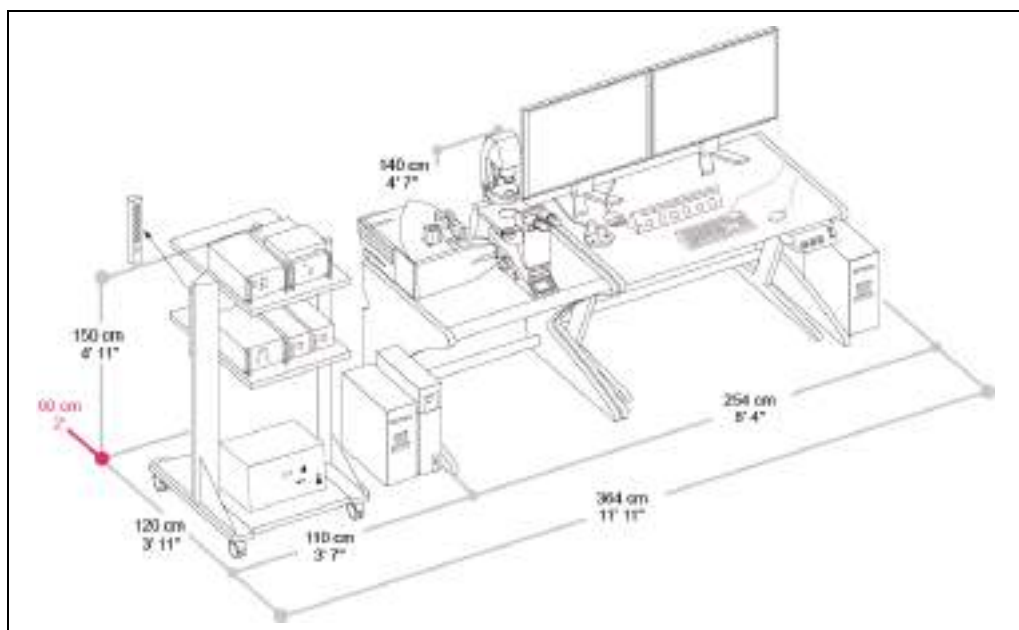
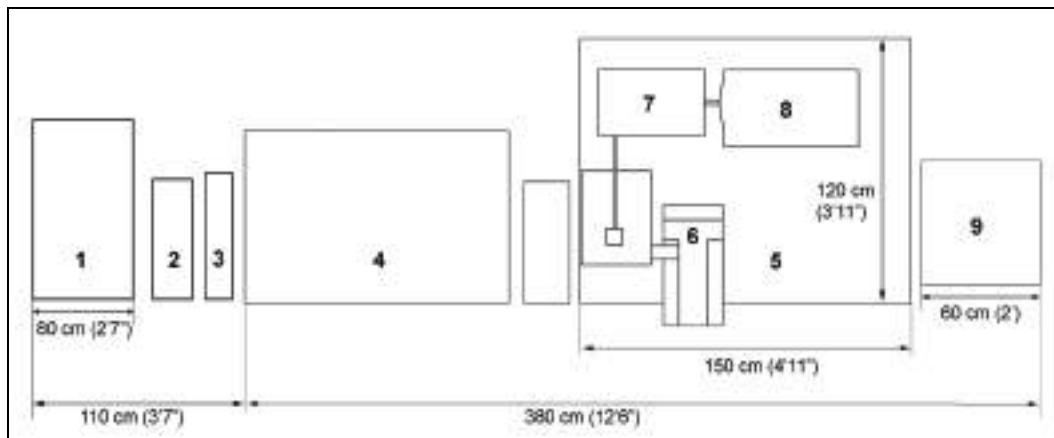

Figure 9: Dimensions of TCS SP8 SMD with white light laser and inverted microscope, without PicoQuant laser

### 7.3 TCS SP8 SMD System Variants with MP Configuration

The system is available with an infrared laser as well. Here, you see the example dimensions for the MP variant with 150 x 120 cm (4'11" x 3'11") optical table. If you should need the dimensions for using a larger table or additional accessories, please look at the Leica TCS SP8 MP Room Requirements.



**Figure 10:** System overview of TCS SP8 SMD with MP configuration upright and inverted microscope possible

- |   |   |
|---|---|
| 1 Trolley with external lasers, detectors and their controllers | 5 Optical table, 150 x 120 cm (4'11" x 3'11") |
| 2 SMD workstation   | 6 Upright or inverted microscope              |
| 3 Microscope electronics box + EL6000 fluorescence lamp         | 7 Beam coupling unit                          |
| 4 Stage with supply unit (compact or flexible)                  | 8 Infrared (IR) laser                         |
|   | 9 Power supply and cooling of the IR laser    |

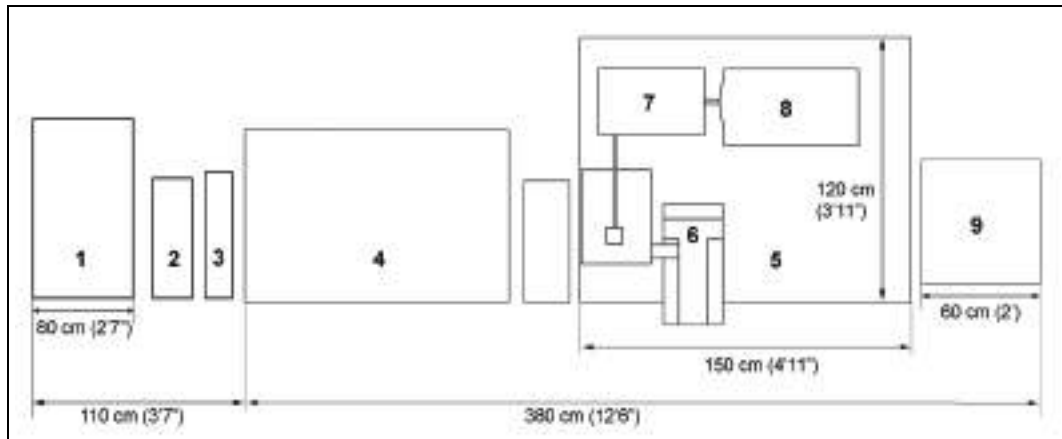

**Figure 11:** System overview of TCS SP8 SMD with MP configuration and white light laser, without PicoQuant laser; upright and inverted microscope possible

- |  |   |
|--|---|
| 1 Trolley with detectors, their controllers and white light lasers | 5 Optical table, 150 x 120 cm (4'11" x 3'11") |
| 2 SMD workstation  | 6 Upright or inverted microscope              |
| 3 Microscope electronics box + EL6000                              | 7 Beam coupling unit                          |
| 4 Stage with supply unit   | 8 Infrared (IR) laser                         |
|  | 9 Power supply and cooling of the IR laser    |

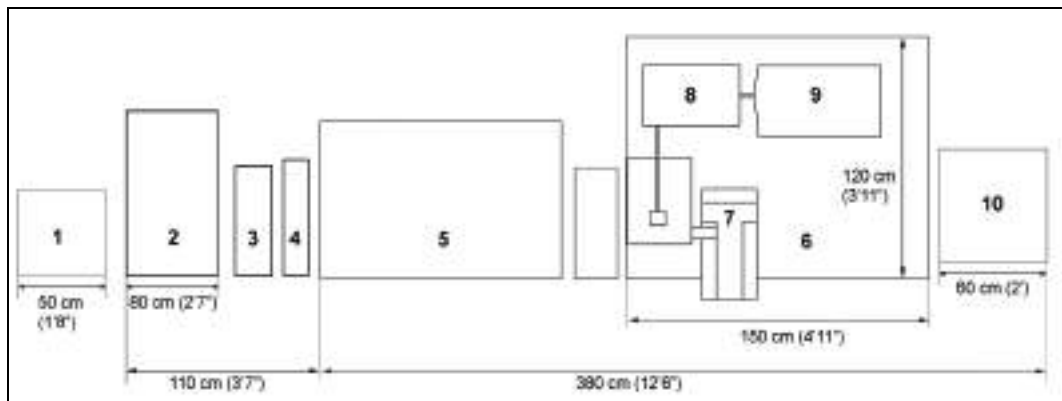

**Figure 12:** System overview of TCS SP8 SMD with MP configuration, white light laser and PicoQuant laser; upright and inverted microscope possible

- |  |   |
|--|---|
| 1 White light laser  | 6 Optical table, 150 x 120 cm (4'11" x 3'11") |
| 2 Trolley with detectors, their controllers and PicoQuant lasers | 7 Upright or inverted microscope              |
| 3 SMD workstation  | 8 Beam coupling unit                          |
| 4 Microscope electronics box + EL6000                            | 9 Infrared (IR) laser                         |
| 5 Stage with supply unit   | 10 Power supply and cooling of the IR laser   |

## 7.4 Controls on the Supply Unit

### 7.4.1 Main Switch Board on the Flexible Supply Unit

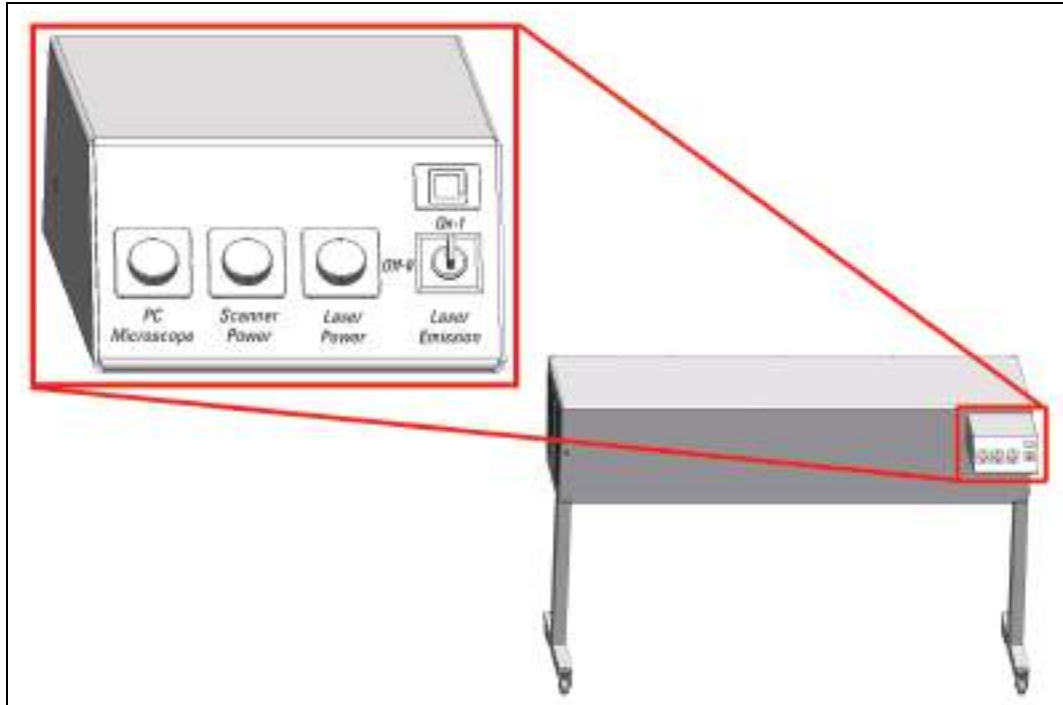

Figure 13: Overview of the main switch board on the flexible supply unit

### 7.4.2 Control Panel Field on the Compact Supply Unit (Only for FLIM)

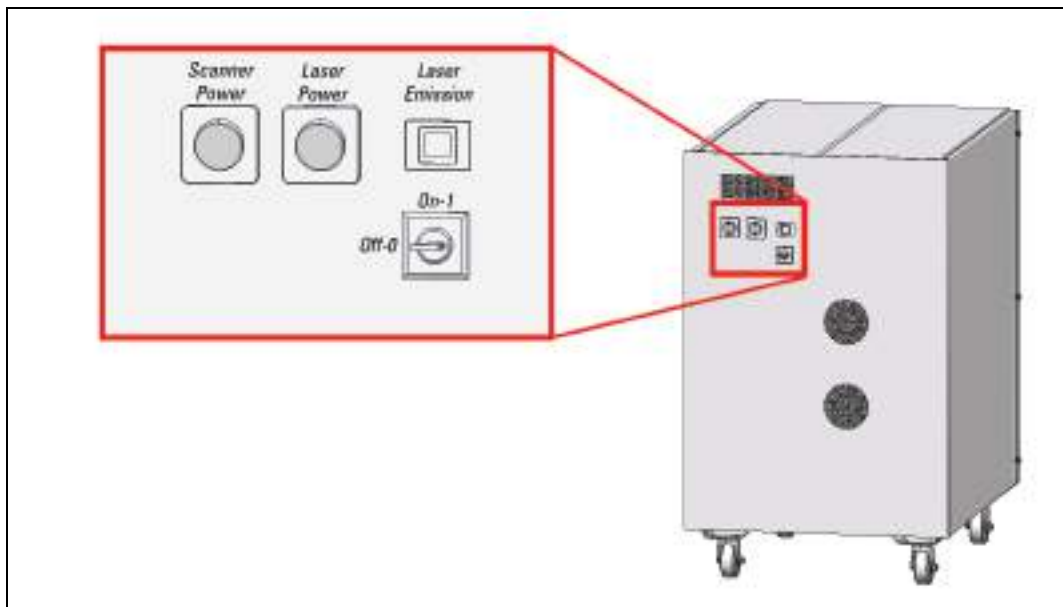

Figure 14: Overview of the control panel field on the Compact supply unit

## 7.5 Technical Data

### 7.5.1 Dimensions

	<b>Dimensions of the system (length x depth x height)</b>
TCS SMD for TCS SP8 with upright microscope, compact and flexible supply unit possible	350 x 120 x 175 cm (11'6" x 3'11" x 5'9")
TCS SMD for TCS SP8 with inverted microscope, compact and flexible supply unit possible	364 x 120 x 150 cm (11'11" x 3'11" x 4'11")
TCS SMD for TCS SP8 X with upright microscope and PicoQuant laser	400 x 120 x 175 cm (13'1" x 3'11" x 5'9")
TCS SMD for TCS SP8 X with upright microscope without PicoQuant laser	350 x 120 x 175 cm (11'6" x 3'11" x 5'9")
TCS SMD for TCS SP8 X with inverted microscope and PicoQuant laser	414 x 120 x 150 cm (13'7" x 3'11" x 4'11")
TCS SMD for TCS SP8 X with inverted microscope without PicoQuant laser	364 x 120 x 150 cm (11'11" x 3'11" x 4'11")
TCS SMD for TCS SP8 MP	max. 490 x 120 x 175 cm (16'1" x 3'11" x 5'9")
TCS SMD for TCS SP8 X with MP configuration without PicoQuant laser	max. 490 x 120 x 175 cm (16'1" x 3'11" x 5'9")
TCS SMD for TCS SP8 X with MP configuration and PicoQuant laser	max. 540 x 120 x 175 cm (17'9" x 3'11" x 5'9")

	<b>Dimensions of the supply unit (length x depth x height)</b>
Compact Supply Unit	38 x 54 x 50 cm (1'3" x 1'9" x 1'8")
Flexible Supply Unit	110 x 70 x 90 cm (3'7" x 2'4" x 2'11")

### 7.5.2 Weight

Weight of the basic TCS SP8 system	330 kg (728 lbs) maximum
Weight of the MP components	Approx. 380 kg (838 lbs)
Weight of the SMD components	160 kg (353 lbs) maximum
Weight of the white light laser	35 kg (77 lbs)

### 7.5.3 Electrical Specifications

	Flexible supply unit	Compact supply unit	White light laser
Supply voltage	100 V~ to 240 V~ ± 10%, grounded		
Power consumption	2x 1600 VA (Including peripheral devices connected to the flexible supply unit's multiple socket outlet, see <b>Chapter 8.5</b> )	700 VA	400 VA
Fuse	LS automated process	2x T8AH, 250 V AC	LS automated process for TCS SP8. 2x T4AH, 250 V AC for white light laser
Protection class	I		
Type of protection	Covered design		
Overvoltage category	II		
Frequency	50/60 Hz		

You can find more information on electrical connection requirements in **Chapter 8.4** and in **Chapter 8.5**.



**Observe the user manuals for external lasers**

Please refer to the information from the documents provided by the laser manufacturer for the external lasers. Pay particular attention to the laser manufacturer's notes!

### 7.6 "Electromagnetic Compatibility"

In regards to emitted interference, this is a class A system (CISPR 11). This system is suitable for use in buildings that do not include domestic premises and buildings not directly connected to a low-voltage power supply network that supplies buildings used for domestic purposes.

The system can cause radio interference in a household environment. In these cases, the operator may have to take measures to eliminate the interference.

When using internal and external HyDs, it is recommended that the system only be operated in a controlled electromagnetic environment. This is because the use of cell phones or other radio transmitting devices such as DECT phones can cause picture interference if used in the immediate vicinity of the system.

## 7.7 Serial Number

The serial number for your system is located on the rear side of the scan head:

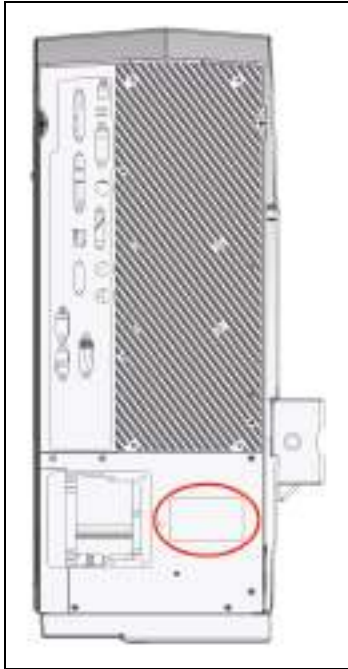

**Figure 15:** Rear side of the scan head – label with serial number



## 8 Ambient Conditions

Here you can find a summary of the information regarding the size and design of the room and the general requirements regarding ambient conditions. Be absolutely sure to comply with the ambient conditions.

### 8.1 General Requirements Regarding Ambient Conditions

- You may use the system only in indoor areas that are dust-free. The room must be free of dust, oil and chemical vapors.
- Avoid direct sunlight and vibrations, since these can distort measurements and micrographic scans. We also recommend using a room that can be completely darkened.
- The room must meet national safety regulations for laser safety areas.
- Never expose the system to rain, fluids, or humidity. Do not set up the system under water pipes, air-conditioning systems, or other piping. Otherwise, this could cause fire and electrical shocks to the system and the electrical components.
- The room should be equipped with a telephone connection to contact Leica Microsystems CMS GmbH for phone support. For RemoteCare, an Internet connection is also needed.
- The system should be set up in a separate room, in order to be able to provide a constant temperature and appropriate ambient lighting without having to address needs of other systems, instruments, and room users.

Temperature range for operation	18 to 25 °C (64 to 77 °F)
optimum optical behavior	22 °C ± 1 °C (72 °F ± 1.8 °F)
Pollution degree	2 (protect system against dust)
Permitted relative humidity	20 to 60% (non-condensing)
Maximum location elevation	2000 m above sea level

- HyD RLDs are cooled. To ensure optimal performance from the detectors, the humidity of the surrounding air must not exceed 60% at 25°C. To prevent potential damage due to condensation, the cooling shuts off automatically if its value is exceeded.

### 8.2 Vibrations

Vibrations must be reduced to a minimum; for that reason, do not set up the system near any of the following sources of vibration: shakers, ultracentrifuges, pumps, compressors, refrigerators, vending machines, elevators.

Maximum tolerable vibrations:

Frequency range [5 Hz – 30 Hz]	less than 30 µm/s root mean square
Frequency range [> 30 Hz]	less than 60 µm/s root mean square

## 8.3 Room Dimensions

The room should be as large as possible so that multiple operators can find room around the system. The free space to the right, left and rear of the system should be 60 cm. In front of the system there must be 110 cm of free space so that the service technicians can access the system as necessary.

### **WARNING** Fire or overheating of the system possible



Electrical peripheral devices must be placed at least 10 cm (4") away from the wall and from flammable substances to prevent overheating or fire of the system.

Also make sure that doors and passages are at least 100 cm wide in order to be able to safely transport the system.

The following minimum size should be planned for the space:

	<b>Room dimensions (length x depth)</b>
TCS SP8 SMD with upright microscope, compact and flexible supply unit possible	470 x 290 cm (15'5" x 9'6")
TCS SP8 SMD with inverted microscope, compact and flexible supply unit possible	484 x 290 cm (15'11" x 9'6")
TCS SP8 SMD with white light laser, upright microscope and PicoQuant laser	520 x 290 cm (17'1" x 9'6")
TCS SP8 SMD with white light laser, upright microscope without PicoQuant laser	470 x 290 cm (15'5" x 9'6")
TCS SP8 SMD with white light laser, inverted microscope and PicoQuant laser	534 x 290 cm (17'6" x 9'6")
TCS SP8 SMD with white light laser, inverted microscope without PicoQuant laser	484 x 290 cm (15'11" x 9'6")
TCS SP8 SMD with MP configuration	610 x 290 cm (20' x 9'6")
TCS SP8 SMD with white light laser and MP configuration, without PicoQuant laser	610 x 290 cm (20' x 9'6")
TCS SP8 SMD with white light laser, MP configuration and PicoQuant laser	660 x 290 cm (21'8" x 9'6")

## 8.4 Electrical Connection Requirements

### **WARNING** Electric shock is possible when using ungrounded sockets



This system is designed for connection to grounded (earthed) outlets. The grounding plug performs an important safety function. To avoid the risk of electrical shock or damage to the instrument, do not disable this feature. Operation without grounded sockets is not permitted.

### 8.4.1 System with Flexible Supply Unit

Supply voltage	100 V~ to 240 V~ $\pm$ 10%, grounded
Frequency	50/60 Hz
Power connection	<p>Three separate electric circuits with            Power supply voltage: 100 V - 120 V, fuse protection: 20 A  <u>or:</u>            Power supply voltage: 200 V - 240 V, fuse protection: 12 - 16 A            (Two for the flexible supply unit's power supply and one for supplying peripheral devices)</p> <p>To prevent damage to the instrument, the two types of voltage (200 to 240 V~ and 100 to 120 V~) must not be combined. Depending on the system configuration, further electrical circuits may be required.</p>
Power supply for USA	Two terminals of the NEMA 5-20 type for the supply unit Terminals of the NEMA 5-15 type for the remaining instruments
for the SMD rack	a separate electric circuit with Power supply voltage: 100 V~ to 240 V~, fuse protection: 16 - 20 A, dependent on local regulations
for the infrared laser and its cooling system (MP configuration)	a separate electric circuit with Power supply voltage: 100 V~ to 240 V~, fuse protection: 12 - 16 A, dependent on local regulations
When using HyD RLDs	An additional power supply

### 8.4.2 System with Compact Supply Unit (Only with FLIM)

Supply voltage	100 V~ to 240 V~ ± 10%, grounded
Frequency	50/60 Hz
Power connection	<p>Two separate electric circuits with                      Power supply voltage: 100 V - 120 V, fuse protection: 20 A  <u>or:</u>                      Power supply voltage: 200 V - 240 V, fuse protection: 12 - 16 A                      (One for the compact supply unit's power supply and one for supplying peripheral devices)</p> <p>To prevent damage to the instrument, the two types of voltage (200 to 240 V~ and 100 to 120 V~) must not be combined. Depending on the system configuration, further electrical circuits may be required.</p>
Power supply for USA	Terminals of type NEMA 5-15
for the SMD rack	a separate electric circuit with Power supply voltage: 100 V~ to 240 V~, fuse protection: 16 - 20 A, dependent on local regulations
for the infrared laser and its cooling system (MP configuration)	a separate electric circuit with Power supply voltage: 100 V~ to 240 V~, fuse protection: 12 - 16 A, dependent on local regulations
When using HyD RLDs	An additional power supply

### 8.4.3 External Lasers

	<p><b>Observe the user manuals for external lasers</b></p> <p>Please refer to the information from the documents provided by the laser manufacturer for the external lasers. Pay particular attention to the laser manufacturer's notes!</p>
---	--

## 8.5 Load capacity of the multiple socket outlet on the flexible supply unit

The total power consumption of all loads connected to the multiple socket outlet (see **Figure 16**) must not exceed 800 VA.

The terminals are intended for:

- Workstation
- Monitor
- Microscope

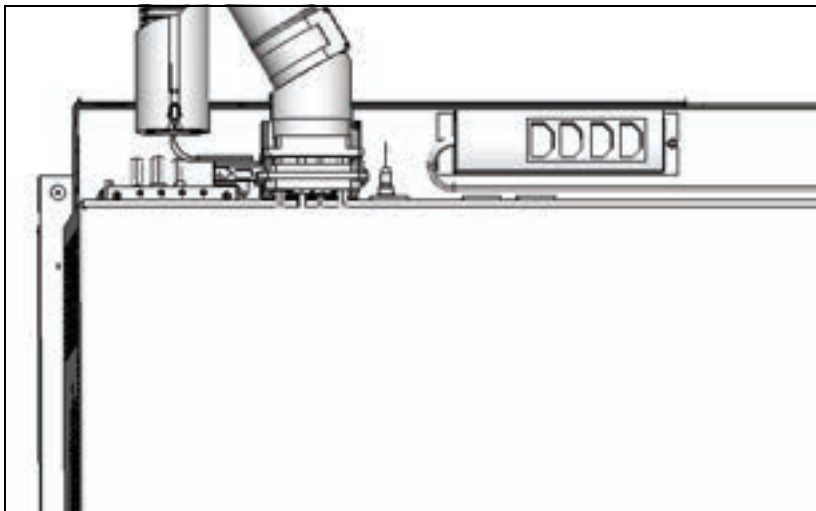

Figure 16: Load capacity on the rear side of the multiple socket outlet on the flexible supply unit

## 8.6 Waste Heat and Cooling

### **NOTICE** Instruments may sustain damage

Never install the system close to air conditioners or other ventilation systems. Air from air-conditioning systems or other ventilation equipment should not blow directly on the microscope.



### **Use a high-performance air-conditioning system**

We recommend a high-performance air-conditioning system for operating the system to prevent large temperature fluctuations in the room.

### 8.6.1 System with Flexible Supply Unit

Waste heat of the complete system, including the argon laser	Max. of 3.9 kW (VIS system with SMD components) Max. of 6.9 kW (MP system with SMD components) Max. 4.3 kW (WLL and VIS system with SMD components) Max. 7.3 kW (WLL and MP system with SMD components)
Waste heat of the argon laser	1.6 kW

For cooling, the argon laser must be connected to the provided argon laser fan. The following space is required:

Standard fan	about 30 x 30 cm (1' x 1')
Noise-reduced laser fan	50 x 60 cm (1'8" x 2')

In addition, it is possible to connect the argon laser exhaust to an in-house exhaust system:

Hose length	400 cm (13'1"), provided by default
Diameter of adapter piece	15 cm (6")
Air flow rate	400 m <sup>3</sup> /h (14,126 ft <sup>3</sup> /h)

The remaining waste heat must be extracted; otherwise the room temperature will rise.

### 8.6.2 System with Compact Supply Unit (Only with FLIM)

Waste heat of the complete system with a compact supply unit	Max. of 2.4 kW (VIS system with SMD components) Max. of 5.4 kW (MP system with SMD components)
--	---

### 8.6.3 External Lasers



**Observe the user manuals for external lasers**

Please refer to the information from the documents provided by the laser manufacturer for the external lasers. Pay particular attention to the laser manufacturer's notes!

## 9 SMD Components

The TCS SMD system combines technologies for individual molecule detection and analysis (SMD = Single Molecule Detection analysis), such as FCS/FCCS, FLIM, FLCS, etc., with confocal imaging. It is a bundle of a confocal or multiphoton microscope from Leica Microsystems CMS GmbH and SMD equipment from PicoQuant GmbH (PQ). The SMD equipment is connected closely to the confocal system via a standard network connection, so that the entire configuration of the workflow of an experiment and the entire control of data acquisition take place on the confocal system only.

### 9.1 Hardware Components and Software Licenses

Depending on the field of application, different hardware and software configurations are possible.

During single photon counting detection for time-resolved measurements, avalanche photodiodes (APD) or photomultipliers (PMTs) can be used.

#### 9.1.1 FCS/FCCS Application Area

##### 9.1.1.1 Special SMD Hardware

Pulsed lasers + laser driver + laser coupling unit (LCU) + coupling	Not necessary. Excitation takes place using the continuous wave lasers (cw lasers) of the TCS SP8.
Detectors for SMD	Only for external detection using APDs: Either: PDM APD from MPD ("MPD"/"SPAD") or: APD of type AQR from Perkin Elmer ("AQR")
Counting unit	TCSPC unit PH300 + Router PHR800

**Table 1: Special SMD hardware for FCS/FCCS**

##### 9.1.1.2 Software License

Leica LAS AF	SMD FCS Wizard
PQ SPT	SPT1

**Table 2: Software license for FCS/FCCS**

## 9.1.2 FLIM Application Area

### 9.1.2.1 Special SMD Hardware

Pulsed lasers	Laser driver	Laser coupling unit (LCU)	Coupling
405 nm	PDL800-B or -D		via UV port in scan head
440 nm	PDL800-B		via MFP in scan head
440 nm + 470 nm	Sepia I	LCU II	via MFP in scan head
470 nm	PDL800-B		via MFP in scan head
470 nm + 640 nm	Sepia I	LCU II	via MFP in scan head
405 nm + 470 nm + 640 nm	Sepia II	LCU II	via UV port and MFP in scan head
WLL			via AOBs
MP (with TDA - trigger diode assembly)			via MFP

**Table 3: Pulsed lasers, laser driver, laser coupling units and coupling for FLIM**

Detectors for SMD	<p>External detection on the X1 port: Either: PDM APD from MPD ("MPD") + DSN102 or: PMA photomultiplier</p> <p>And/or internal detection: SP FLIM photomultiplier (within spectral module) Or external detection at the NDD position with MP FLIM excitation: HyD RLD</p>
Counting unit	TCSPC unit PH300 + with multiple detectors: Router PHR800

**Table 4: Special SMD hardware for FLIM**

### 9.1.2.2 Software License

Leica LAS AF	SMD FLIM Wizard
PQ SPT	SPT2

**Table 5: Software license for FLIM**

## 9.1.3 Application area FCS/FCCS, FLIM, FLCS, gated FCS

### 9.1.3.1 Special SMD Hardware

Pulsed lasers + laser driver + laser coupling unit (LCU) + coupling	as with MP-FLIM
Detectors for SMD	External detection: PDM APD from MPD ("MPD") + DSN102 And/or internal detection: SP FLIM photomultiplier (within spectral module, used for spectral FLIM)
Counting unit	TCSPC unit PH300 + Router PHR800

**Table 6: Special SMD hardware for FCS/FCCS, FLIM, FLCS, gated FCS**

### 9.1.3.2 Software License

Leica LAS AF	FCS Wizard + FLIM Wizard
PQ SPT	SPT1+2

**Table 7: Software license for FCS/FCCS, FLIM, FLCS, gated FCS**

## 9.2 Beam Path

The fluorescence necessary for SMD measurement is excited by means of lasers, which are coupled into the scan head. For FCS and FCCS, continuous wave (cw) lasers are normally used. However, pulsed lasers can also be used. For FLIM, FLCS or gated FCS, only pulsed lasers can be used.

The excitation light reaches the specimen through the scan head. The light is collected by the objective and passes through the scan head to the SMD detectors that can be either within the spectral module in the scan head or outside the scan head.

For SMD, special detectors are needed that work in single photon counting mode and have a low background signal. For FLIM, additionally, a high time resolution is necessary, whereas for FCS a high quantum efficiency is crucial. Therefore, different detectors can be used, depending on the field of application (see **Table 1**, **Table 4** and **Table 6**).

When confocal, external detectors are used, light is split off to optical fibers at the external interface X1 ("X1 port") with the aid of the X1 adapter, then guided to the photodetectors via multimode waveguides (**Figure 17**). These waveguide fibers enable the scan head to be mechanically decoupled from the detectors. If two external detectors are used, light is split by a beam splitter into the two detection channels. The beam splitter is situated in the SMD filter cube that is placed in the X1 port adapter on the X1 port.

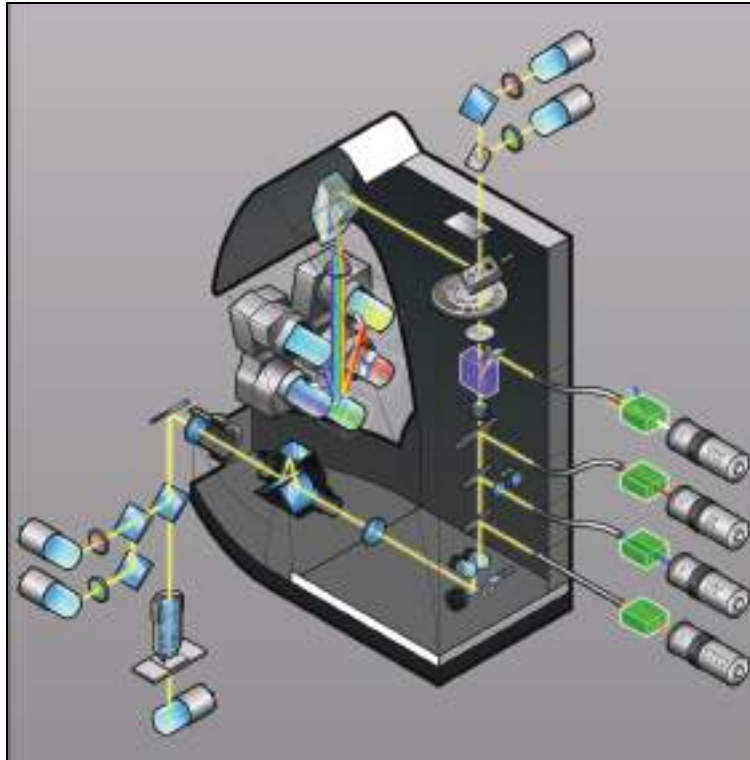

Figure 17: SP8 scan head with APD detection at the external X1 port

### 9.3 Detection Units from PicoQuant

The following detection units are available for SMD upgrades:



Figure 18: Single-channel PMT detection unit



Figure 19: Double-channel PMT detection unit



Figure 20: Single-channel APD detection unit



Figure 21: Double-channel APD detection unit

**Chapter 23** includes instructions for replacing the filter cube in the X1 port adapter that splits the emission light onto the two APDs.

## 9.4 Leica APD Detector Unit

Two APDs (of type AQR from Perkin Elmer) are located in the Leica APD detector unit (**Figure 22**). They are linked to the X1 port adapter on the scan head using optical fibers. At the APD detector unit, the APDs can be switched on independently of one another (**Figure 22, item 1 and 2**). In addition to the switches for the APDs, the front side of the control unit also includes indicators for the power supply (**Figure 22, item 3**). The power switch itself is on the rear of the APD detector unit (**Figure 22, item 5**).



Figure 22: Leica APD detector unit

The photon counting signal generated by the APDs is recorded by the PicoHarp 300 and analyzed by a second workstation using SymPhoTime software.

**Chapter 23** includes instructions for replacing the filter cube in the X1 port adapter that splits the emission light onto the two APDs.

## 9.4.1 General Precautionary Measures for Using APD Detector Units

- Never switch the APDs on with a light source switched on. To prevent inadvertent illumination of the APDs, in the Leica LASAF software, place the external port (**X1 Port**) in **Beam Path Settings** in the LAS AF software in the **mirror** position (see **Chapter 16.1.1** and **Chapter 18.2.1**) before you switch on the APDs.
- Do not switch the APDs on until just before they are to be used. They require about 30-60 seconds before they are ready for operation. Always switch the APDs off again after use.
- The APDs can be switched on independently of one another. Only switch on the APD(s) that you really need.
- As far as possible, avoid working in reflection. In order to work in fluorescence mode, switch the AOBs to fluorescence. For the excitation, select laser lines that are outside the detection zones defined by the filter cube. Switch the APDs off before you change the filter cube.

## 9.4.2 Changing the Fuse

The fuse is in the device connector on the back of the APD detector unit. When replacing the fuse, there must be no voltage at the APD detector unit (disconnect the mains plug).

## 9.4.3 Safety Shutoff

<b>NOTICE</b>	<b>Light that is too intense may damage the APDs</b>
---------------	--

Prevent a light intensity that is too high (due to too high laser intensity or room illumination) on the APDs. Otherwise, the detectors can be damaged irreparably.

APDs are extremely sensitive detectors which can be damaged irreparably by light that is too intense (such as room lighting). For this reason, APDs are protected by an automatic shut-off. If the light that falls on the APDs is too intense, they are switched off for a few seconds and an audible warning signal is emitted. The APDs are automatically reactivated after a few seconds.

If you hear the audible warning signal, either switch off the APDs or reduce the light intensity that reaches the APDs (e.g. by reducing the light intensity of the laser).

## 9.5 Trigger Unit

The trigger unit transfers electronic signals (like frame and line clocks for FLIM images) from the SP8 scan head to the TCSPC counting device.



Figure 23: Front side of the trigger unit



Figure 24: Rear side of the trigger unit

## 9.6 Laser Coupling Unit (LCU)

**WARNING** Risk of permanent eye and skin damage from laser radiation



The laser coupling unit must not be opened. The adjustment of the laser beam and the coupling must be carried out by a service technician.

In the laser coupling unit (LCU), there are up to four pulsed lasers. It combines and couples one or more pulsed VIS laser beams (e.g. 440 nm up to 640 nm) into a polarization-maintaining single mode (PM-SM) laser (**Figure 25**). This laser is coupled into the multifunction port (MFP) of the SP8 scan head.

In the UV range (e.g. 405 nm) a separate laser output is used that is coupled to the UV port of the SP8 scan head.



Figure 25: Laser Coupling Unit (LCU)

## 9.6.1 Attenuation Unit

The laser coupling module contains an attenuation unit which enables a graduated and continuous intensity attenuation via two different elements: a filter wheel and a scaffold (**Figure 26**).

Using the filter wheel, the attenuation is adjustable in three steps (between four positions) by replacing the filter in the beam paths:

- 0 = 100% transmission
- 1 = 10% transmission
- 2 = 1% transmission
- 3 = 0.1% transmission

The additional scaffold allows a continuous attenuation (100% to 0%) by clipping the laser beams. The scaffold is controlled by a micrometer screw and enables precision control of the intensity.

Note that the attenuation unit is placed in a position where all laser beams come through. This ensures that the attenuation of the ND filters (neutral density filters) is equal for all beams. However, the attenuation achieved with the scaffold can be different profile for the specific laser beams due to differences in the shape and orientation of the beam profile.

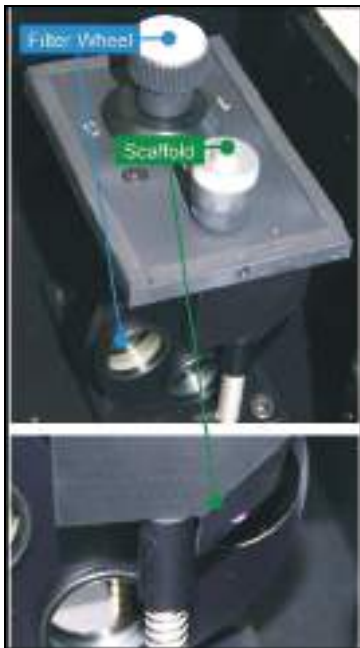

**Figure 26:** Attenuation unit with filter wheel and scaffold.

## 9.6.2 Other PicoQuant Components



Figure 27: PicoHarp 300 TCSPC unit



Figure 28: Router PHR 800. A multi-photomultiplier configuration is shown here.



Figure 29: Laser drivers for pulsed diode lasers: PDL 828 Sepia II



Figure 30: Laser drivers for pulsed diode lasers: PDL 800-B



Figure 31: DSN 102 Dual SPAD Power Supply

## 10 Laser

It is mandatory to observe the laser safety measures for laser class 3B / IIIb (VIS and UV lasers) or for laser class 4 / IV (MP systems) in accordance with applicable national and federal regulations.

You may only use the laser listed here, as the laser safety devices are only designed for the laser variants listed here.

### 10.1 Laser Classes

System variant	System variant laser class	Usable lasers	Wavelength range
TCS SP8 SMD	3B / IIIb	VIS	400 - 700 nm (visible laser radiation)
		UV	350 - 400 nm (invisible laser radiation)
TCS SP8 SMD with WLL	3B / IIIb	VIS	400 - 700 nm (visible laser radiation)
		UV	350 - 400 nm (invisible laser radiation)
TCS SP8 SMD with MP configuration	4 / IV	VIS	400 - 700 nm (visible laser radiation)
		UV	350 - 400 nm (invisible laser radiation)
		IR	680 - 1600 nm (invisible laser radiation)

### 10.2 Overview of Usable Lasers for Image Acquisition

#### 10.2.1 VIS/UV Lasers for TCS SP8

The TCS SP8 features a combination of the lasers listed below:

Laser type	Wavelength (nm)	Maximum light output at laser output (mW)	Maximum light output in focal plane (mW)	Pulse duration
UV, external	355	< 500	< 18	Continuous wave (cw)
Diode 405	405	< 120	< 7	Continuous wave (cw)
Diode 405 p	405	< 5 (mean power)	< 0.3 (mean power)	pulsed, 60 ps
Diode 442	442	< 75	< 7	Continuous wave (cw)
Diode 448	448	100	10	Continuous wave (cw)
Ar	458, 476, 488, 496, 514	< 200	< 50	Continuous wave (cw)
OPSL 488	488	350	10	Continuous wave (cw)

OPSL 514	514	350	10	Continuous wave (cw)
OPSL 552	552	350	10	Continuous wave (cw)
DPSS 561	561	< 100	< 12	Continuous wave (cw)
HeNe	594	< 4	< 1	Continuous wave (cw)
HeNe	633	< 15	< 5	Continuous wave (cw)
Diode 638	638	350	10	Continuous wave (cw)

## 10.2.2 VIS/UV Lasers for TCS SP8 X

The TCS SP8 X features a combination of the lasers listed below:

Laser type	Wavelength (nm)	Maximum light output at laser output (mW)	Maximum light output in focal plane (mW)	Pulse duration
Diode 405	405	< 120	< 7	Continuous wave (cw)
Diode 405 p	405	< 5 (mean power)	< 0.3 (mean power)	pulsed, 60 ps
UV, external	355	< 500	< 18	Continuous wave (cw)
Ar	458, 476, 488, 496, 514	< 200	< 50	Continuous wave (cw)
White light laser	470 – 670	< 500	< 50	Pulsed

## 10.2.3 IR lasers for TCS SP8 MP

The TCS SP8 MP can include a combination of all of the lasers listed in **Chapter 10.2.1** and **Chapter 10.2.2** - except for the external UV laser (355 nm) - and the following IR lasers:

### 10.2.3.1 Picosecond laser

Laser type	Wavelength (nm)	Maximum light output at laser output (W)	Maximum light output in focal plane (W)	Pulse duration
MaiTai HP ps	690 - 1040	< 3,5	< 1,9	pulsed, 1.0 - 1.5 ps
Chameleon Ultra II ps	680 - 1080	< 4	< 1,9	pulsed, 1.0 - 1.5 ps

### 10.2.3.2 Femtosecond laser

Laser type	Wavelength (nm)	Maximum light output at laser output (W)	Maximum light output in focal plane (W)	Pulse duration
MaiTai fs	780 - 920	< 1,2	< 0,6	pulsed ~ 80 fs
MaiTai HP fs	690 - 1040	< 3,5	< 1,9	pulsed ~ 100 fs
MaiTai HP Deep See	690 - 1040	< 3,5	< 1,9	pulsed ~ 100 fs
MaiTai eHP Deep See	690 - 1040	< 3,5	< 1,9	pulsed ~ 70 fs
Chameleon Ultra I fs	690 - 1040	< 4	< 1,9	pulsed ~ 140 fs
Chameleon Ultra II fs	680 - 1080	< 4	< 1,9	pulsed ~ 140 fs
Chameleon Vision II	680 - 1080	< 4,0	< 1,9	pulsed ~ 140 fs
Chameleon Vision S	690 - 1050	< 3,5	< 1,9	pulsed ~ 75 fs
Chameleon Ultra II Compact OPO	680 - 1080	< 4,0	< 1,9	pulsed ~ 140 fs
	1000 - 1300	< 1,6	< 0,8	pulsed > 100 fs
Chameleon Vision II Compact OPO	680 - 1080	< 4,0	< 1,9	pulsed ~ 140 fs
	1000-1280	< 1,6	< 0,8	pulsed > 100 fs

## 10.3 Overview of Usable Lasers for FCS

### 10.3.1 VIS/UV Lasers for TCS SP8 SMD

The TCS SP8 SMD (for FCS) features a combination of the lasers listed below:

Laser type	Wavelength (nm)	Maximum light output at laser output (mW)	Maximum light output in focal plane (mW)	Pulse duration
Ar	458, 476, 488, 496, 514	< 200	< 50	Continuous wave (cw)
DPSS 561	561	< 100	< 12	Continuous wave (cw)
HeNe	594	< 4	< 1	Continuous wave (cw)
HeNe	633	< 15	< 5	Continuous wave (cw)
Diode 638	638	350	10	Continuous wave (cw)
White light laser	470 – 670	< 500	< 50	Pulsed

## 10.4 Overview of usable lasers for FLIM

### 10.4.1 VIS/UV Lasers for TCS SP8 SMD

The TCS SP8 SMD (for FLIM) features a combination of the lasers listed below:

Laser type	Wavelength (nm)	Maximum light output at laser output (mW)	Maximum light output in focal plane (mW)	Pulse duration
405 pulsed	405	3 @ 40 MHz	0.1 @ 40 MHz	pulsed, >80 ps
405 dual-voltage	405	3 @ 40 MHz	0.1 @ 40 MHz	Pulsed + continuous wave (cw) >80 ps
440	440	3 @ 40 MHz	0.1 @ 40 MHz	pulsed, >80 ps
470	470	3 @ 40 MHz	0.3 @ 40 MHz	pulsed, >80 ps
640	640	4.5 @ 40 MHz	0.5 @ 40 MHz	pulsed, >80 ps
White light laser	470 – 670	< 500	< 50	Pulsed

### 10.4.2 Infrared Lasers for TCS SP8 SMD with MP Configuration

The TCS SP8 SMD with MP configuration (for FLIM) can contain a combination of all the infrared lasers in **Chapter 10.4.1** and the following infrared lasers:

#### 10.4.2.1 Picosecond laser

Laser type	Wavelength (nm)	Maximum light output at laser output (W)	Maximum light output in focal plane (W)	Pulse duration
MaiTai HP ps	690 - 1040	< 3,5	< 1,9	pulsed, 1.0 - 1.5 ps
Chameleon Ultra II ps	680 - 1080	< 4	< 1,9	pulsed, 1.0 - 1.5 ps

#### 10.4.2.2 Femtosecond laser

Laser type	Wavelength (nm)	Maximum light output at laser output (W)	Maximum light output in focal plane (W)	Pulse duration
MaiTai fs	780 - 920	< 1,2	< 0,6	pulsed ~ 80 fs
MaiTai HP fs	690 - 1040	< 3,5	< 1,9	pulsed ~ 100 fs
MaiTai HP Deep See	690 - 1040	< 3,5	< 1,9	pulsed ~ 100 fs
MaiTai eHP Deep See	690 - 1040	< 3,5	< 1,9	pulsed ~ 70 fs
Chameleon Ultra I fs	690 - 1040	< 4	< 1,9	pulsed ~ 140 fs
Chameleon Ultra II fs	680 - 1080	< 4	< 1,9	pulsed ~ 140 fs

Chameleon Vision II	680 - 1080	< 4,0	< 1,9	pulsed ~ 140 fs
Chameleon Vision S	690 - 1050	< 3,5	< 1,9	pulsed ~ 75 fs
Chameleon Ultra II Compact OPO	680 - 1080	< 4,0	< 1,9	pulsed ~ 140 fs
	1000 - 1300	< 1,6	< 0,8	pulsed > 100 fs
Chameleon Vision II Compact OPO	680 - 1080	< 4,0	< 1,9	pulsed ~ 140 fs
	1000-1280	< 1,6	< 0,8	pulsed > 100 fs

## 10.5 Overview of Usable Lasers for FLCS

### 10.5.1 VIS/UV Lasers for TCS SP8 SMD

The TCS SP8 SMD (for FLCS) features a combination of the lasers listed below:

Laser type	Wavelength (nm)	Maximum light output at laser output (mW)	Maximum light output in focal plane (mW)	Pulse duration
405 pulsed	405	3 @ 40 MHz	0.1 @ 40 MHz	pulsed, >80 ps
405 dual-voltage	405	3 @ 40 MHz	0.1 @ 40 MHz	Pulsed + continuous wave (cw) >80 ps
440	440	3 @ 40 MHz	0.1 @ 40 MHz	pulsed, >80 ps
470	470	3 @ 40 MHz	0.3 @ 40 MHz	pulsed, >80 ps
640	640	4.5 @ 40 MHz	0.5 @ 40 MHz	pulsed, >80 ps
White light laser	470 – 670	< 500	< 50	Pulsed

# 11 Safety Features

The Leica TCS SP8 SMD system is available with a flexible or a compact supply unit (only for FLIM). Note the safety features described here that apply to your supply unit.

## 11.1 Main Circuit Breaker for Disconnecting the Power Supply

### 11.1.1 Compact Supply Unit

In order to switch the power off on the compact supply unit, the power plug must be disconnected.

### 11.1.2 Flexible Supply Unit

The main circuit breaker is located on the right rear side of the flexible supply unit. It is used to de-energize the complete system using a single switch (see **Figure 32**).

The main circuit breaker functions as a switch and as an overcurrent fuse. The main circuit breaker is not to be used as the regular on/off switch for the system.

The supply unit must be set up so that the main circuit breaker is freely accessible at all times.

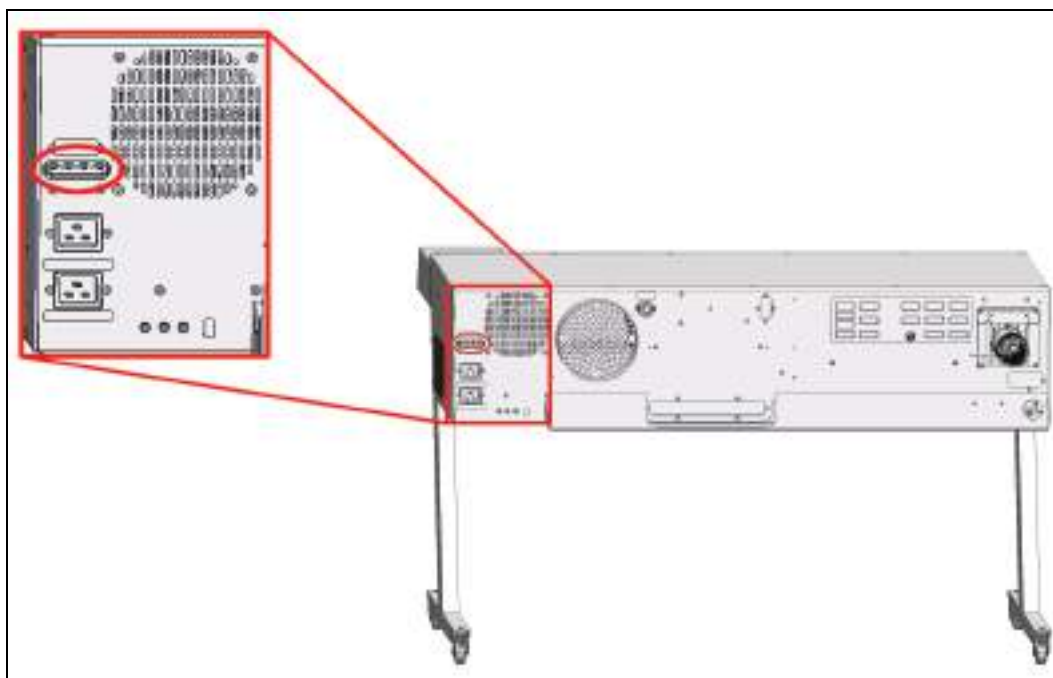

**Figure 32:** Rear side of the flexible supply unit with the main circuit breaker

### 11.1.3 Other Components



#### Observe the user manuals for other components

You can find information on the network equipment for additional components from the respective documents provided by the manufacturer.

## 11.2 Key Switch

### 11.2.1 Master Key Switch on the Compact Supply Unit

There is a master key switch on the compact supply unit for protection against unauthorized use of the laser products. This master key switch is integrated in the interlock circuit. If the master key switch is in the "off" position, all laser beam paths are interrupted. Then no radiation from lasers integrated in the supply unit or the external lasers can reach the specimen area, even if the key switches of the external lasers are in the "on" position.

The master key switch for the compact supply unit is located on the front side of the unit (see **Figure 33**).

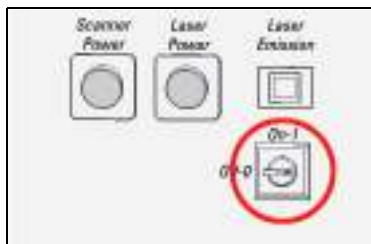

**Figure 33:** Master key switch on the compact supply unit

### 11.2.2 Master Key Switch on the Flexible Supply Unit

There is a master key switch on the flexible supply unit for protection against unauthorized use of the laser products. This master key switch is integrated in the interlock circuit. If the master key switch is in the "off" position, all laser beam paths are interrupted. Then no radiation from lasers integrated in the supply unit or the external lasers can reach the specimen area, even if the key switches of the external lasers are in the "on" position.

The master key switch for the flexible supply unit is located on the front side of the main switch board (see **Figure 34**).

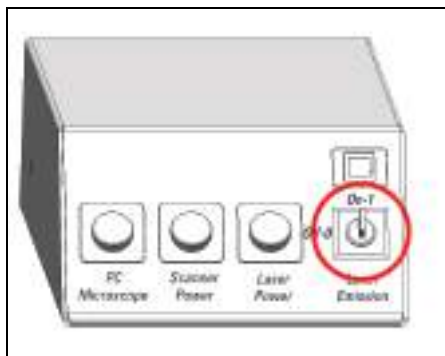

Figure 34: Master key switch on the main switch board of the flexible supply unit

### 11.2.3 Key Switch for the White Light Laser

The external lasers can also be turned off individually. The detachable key switch for protection against unauthorized use of the external white light laser is located on the front of the white light laser (see **Figure 35**).

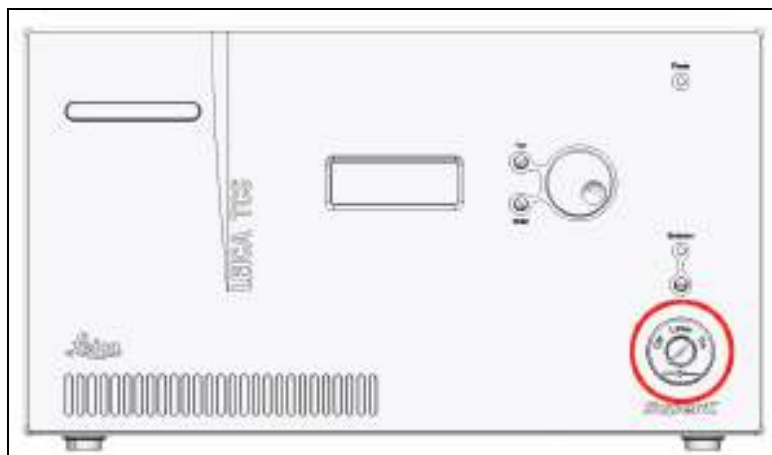

Figure 35: Key switch for the white light laser

### 11.2.4 Key Switch for UV Lasers



Figure 36: Key switch on the power supply of external UV laser 355

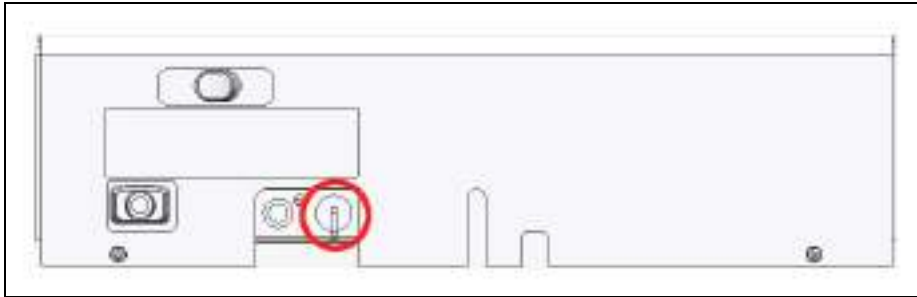

Figure 37: Key switch on external UV laser 405

### 11.2.5 Key Switches for Other External Lasers



**Observe the user manuals for external lasers**

Please refer to the information from the documents provided by the laser manufacturer for the external lasers. Pay particular attention to the laser manufacturer's notes!

## 11.3 Emission Warning Indicators

The operational readiness of lasers is signaled by an emission warning indicator.

**WARNING Risk of permanent eye and skin damage from laser radiation**



From this time on, laser radiation may be present in the specimen area of the laser scanning microscope. Make sure to follow the safety notes for operation of the system.

### 11.3.1 Emission Warning Indicator on the Supply Unit

The emission warning indicator on the supply unit is connected to the master key switch. If this is illuminated, there is the possibility of laser radiation in the specimen plane. If the master key switch is in the "off" position, the emission warning indicator on the supply unit goes out.

The emission warning indicator is located on the supply unit above the key switch, and it lights up in yellow (for compact supply units, see **Figure 38**, for flexible supply units see **Figure 39**).

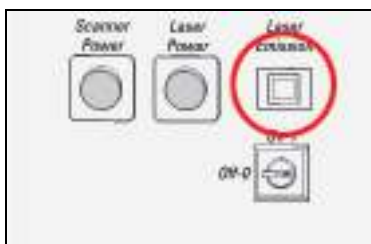

Figure 38: Emission warning indicator on the compact supply unit

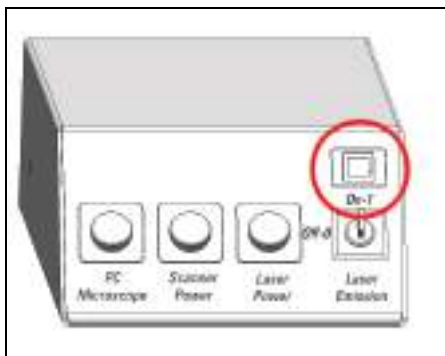

Figure 39: Emission warning indicator on the main switch board of the flexible supply unit

### 11.3.2 Emission Warning Indicator on the White Light Laser

The emission warning indicator of the achromatic light laser is located on the front of the achromatic light laser (see **Figure 40**) and is red when lit.

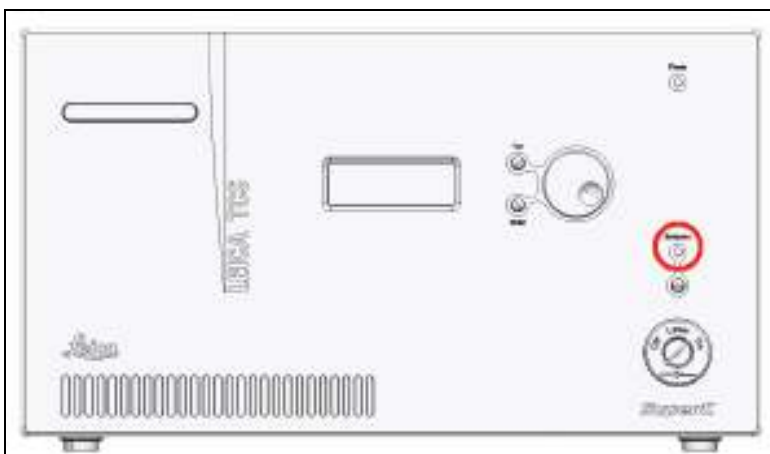

Figure 40: Emission warning indicator on the white light laser

### 11.3.3 Emission Warning Indicator on UV Lasers

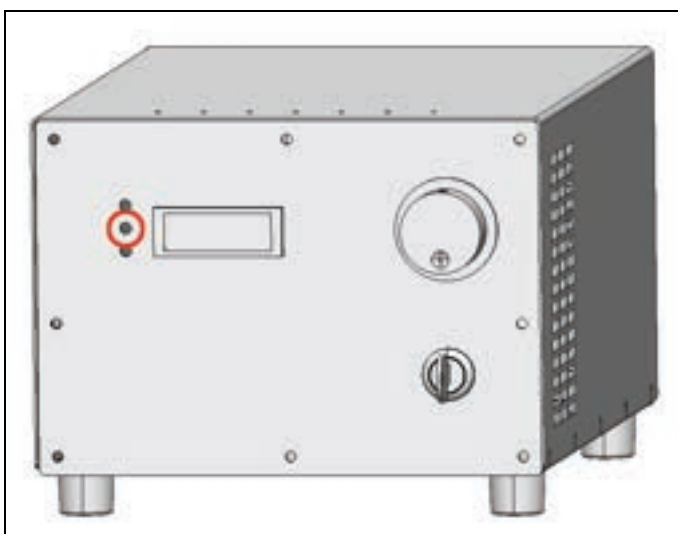



Figure 41: Emission Warning Indicator on Power Supply of External UV Laser 355



Figure 42: Emission Warning Indicator on External UV Laser 405

### 11.3.4 Emission Warning Indicator on Other External Lasers



**Observe the user manuals for external lasers**

Please refer to the information from the documents provided by the laser manufacturer for the external lasers. Pay particular attention to the laser manufacturer's notes!

### 11.3.5 Malfunction of Emission Warning Indicator

**WARNING** **Malfunction of emission warning indicator**

You must immediately disconnect the system from the power supply if any of the following occur:

- The emission warning indicator is not lit after being switched on using the detachable-key switch.
- The indicator continues to be lit after being switched off using the keyswitch
- Scanning of the specimen is not activated after being switched on properly (laser radiation in the specimen area).

If any of these occur, immediately notify the Leica branch office in your country or your local contact person.



## 11.4 Interlock Connectors

### 11.4.1 Interlock Connector on the Supply Unit

The interlock connector (plug connection for the remote-controlled safety "interlock") is on the rear side of the supply unit. Operating voltage is 12 V DC (for the flexible supply unit see **Figure 44**; for the compact supply unit see **Figure 43**).

The interlock connector on the supply unit has a shorting plug in its factory condition. The shorting plug is removable in order to connect a remote-controlled safety interlock (cable and safety switch). The laser beam path is interrupted if the contact is open. The safety interlock can, for example, be connected to a door contact. When the door is opened, the laser beam is then interrupted automatically.

The total length of the cable must not exceed 10 m. If a large amount of electromagnetic interference (EMC) is expected in the environment, use a shielded cable with a shielded plug.



**Figure 43:** Interlock connector on the compact supply unit

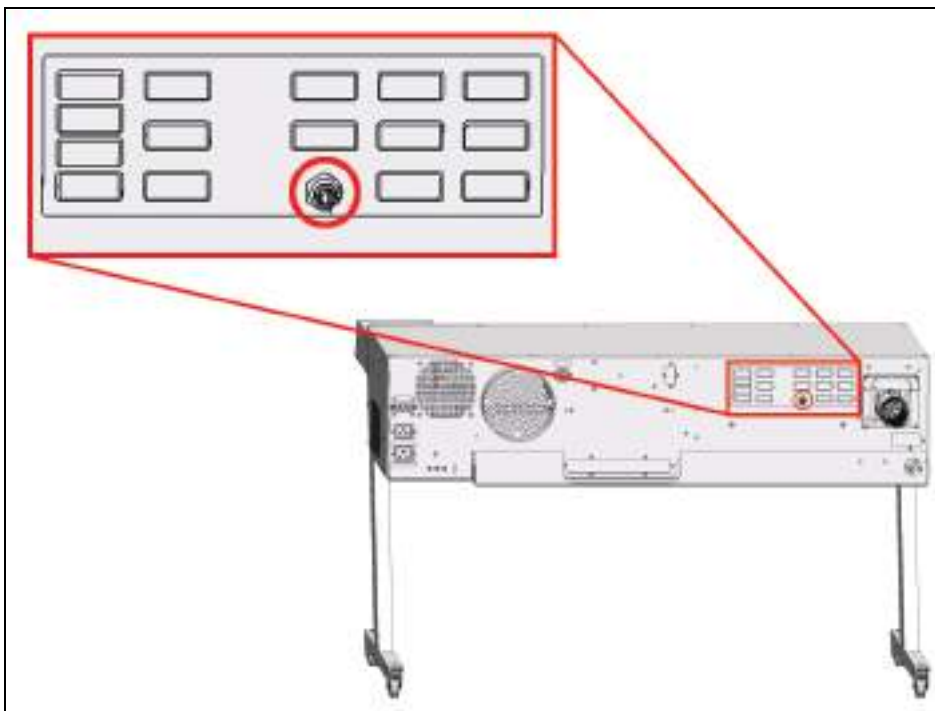

**Figure 44:** Interlock connector on the rear side of the flexible supply unit

## 11.4.2 Interlock Connector on the White Light Laser

The interlock connector is located on the rear side of the white light laser (12 V DC operating voltage, see **Figure 45**).

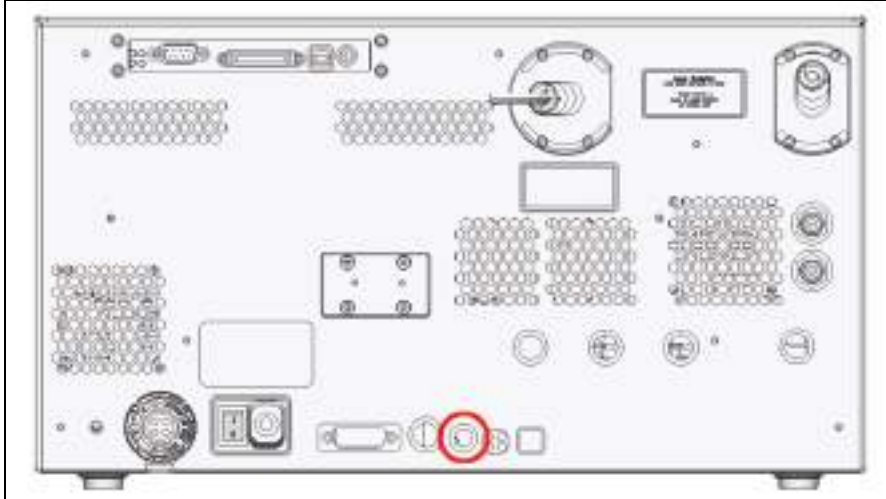

**Figure 45:** Interlock Connector on the White Light Laser

### Interlock connector when using the white light laser



If the white light laser is operated as a component of the TCS SP8 X system, you have to use the interlock connector on the supply unit! The shorting plug must be connected to the interlock connector of the white light laser.

If you operate the white light laser separately (without connecting it to the TCS SP8 system), you have to use the interlock connector on the white light laser for connecting remote interlocks.

Remote interlock devices such as those connected to the room, the door or other onsite safety interlock systems can also be connected to the remote interlock connector. The laser beam path is interrupted if the contact is open.

## 11.4.3 Interlock Connector on Other External Lasers



### Observe the user manuals for external lasers

Please refer to the information from the documents provided by the laser manufacturer for the external lasers. Pay particular attention to the laser manufacturer's notes!

#### 11.4.4 Interlock Connector on the Scan Head

The interlock connector is located on the rear side of the scan head (operating voltage: 12 V DC, see **Figure 46**).

For laser safety reasons, the inverted microscope must be connected to this connection or, if an upright microscope is used, to the mirror housing. This ensures that the microscope safety switch is integrated in the interlock circuit.

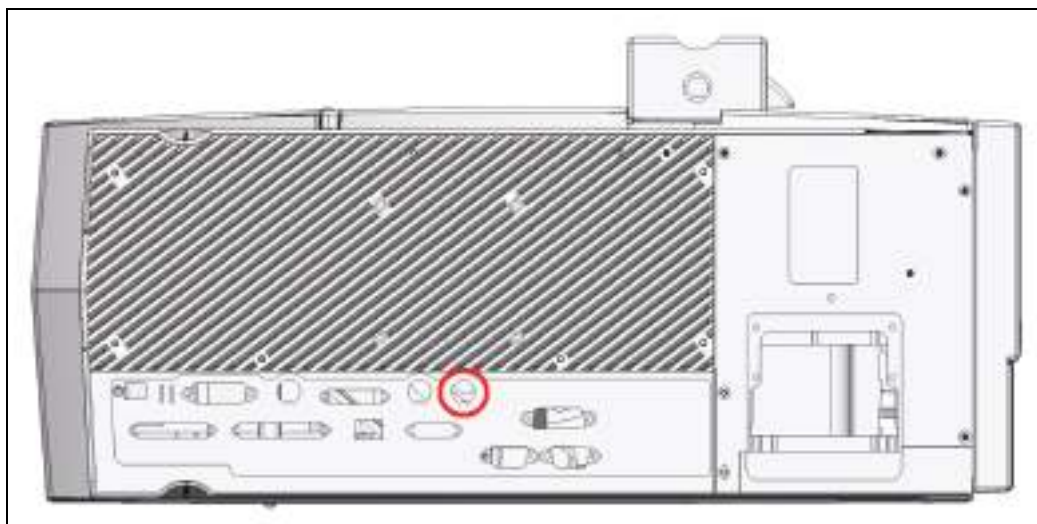

**Figure 46:** Position of the interlock connector on the scan head

## 11.5 Safety Switches on the Microscope

When the safety switches are triggered, the light path of the laser beam is interrupted.

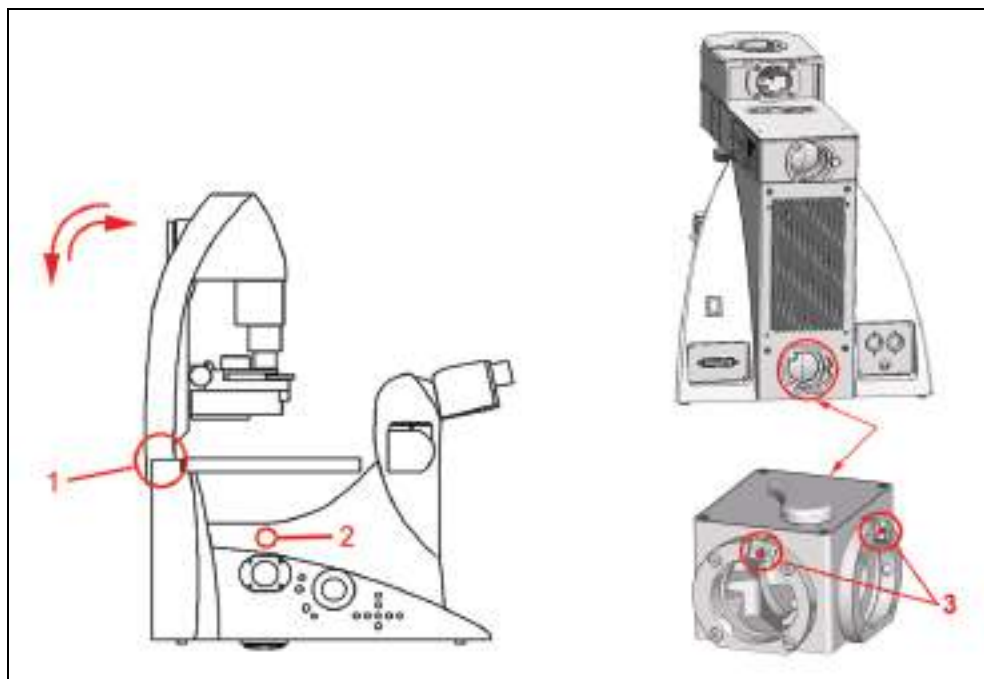

Figure 47: Safety switches (1) and (2) on the inverted microscope (left); Safety switches (3) on the mirror housing for the upright microscope (right)

Position of the safety switch	Is triggered by	Is triggered if	Function
1	Transmitted-light illuminator arm	The illuminator arm is tilted (e.g. for working on the specimen)	Prevents laser light while working on the specimen
2	Motorized changeover from eyepiece mode to scan mode	The path-folding mirror for the scan head is swung out by motor	Prevents stray light in the eyepiece if the user switches from eyepiece observation to confocal observation
3	Pushbutton in the port apertures of the mirror housing	One of the two apertures on the mirror housing is free (no external detector, no halogen lamps, no cover)	Prevents the escape of laser light if the user removes components from the mirror housing.

## 11.6 Warning Messages

- Warning messages in the event of a defective shutter:** The shutters are monitored for safety. If one of the shutters is defective or not functioning properly, a warning message is shown on the monitor within the LAS AF. For safety reasons, the shutters remain closed. No further use of the laser is possible. In this situation, the system must not be operated. Contact the Leica branch office in your country or your contact person.

- **Audible warning signal in the case of defective parts in the shutter safety circuit:** If a part in the shutter safety circuit is defective, a tone **sounds at intervals**. For safety reasons, the shutters remain closed. No further use of the laser is possible. In this situation, the system must not be operated. Contact the Leica branch office in your country or your contact person.
- **Audible warning signal in case of defective laser emission indicator port:** The relay contact for the laser emission indicator port is safety monitored. If the relay fails, an **audible warning signal sounds at regular intervals**. Notify Leica Service immediately. If a laser emission indicator is connected to the laser emission indicator port, the system may not be operated.
- **Audible warning signal during automatic firmware update:** During the update of the firmware, a **continuous tone sounds**. After the updated component is automatically restarted, the signal stops. During the automatic update and the automatic restart of the component, you may not switch off or restart the system, since otherwise this can lead to damage to the system.
- **Warning signal in the case of light that is too intense reaching the APDs:** APDs are extremely sensitive detectors which can be damaged irreparably by light that is too intense (such as room lighting). For this reason, APDs are protected by an automatic shut-off. If the light that falls on the APDs is too intense, they are switched off for a few seconds and an audible **warning signal** is emitted. The APDs are automatically reactivated after a few seconds. Either switch off the APDs or reduce the light intensity (e.g. by reducing the light intensity of the laser).

## 11.7 Special Laser Safety Equipment

### 11.7.1 Laser Protection Tube and Laser Protection Shield

The laser protection tube and the laser protection shield are used in inverted microscopes for protection from laser radiation (see **Figure 48**).

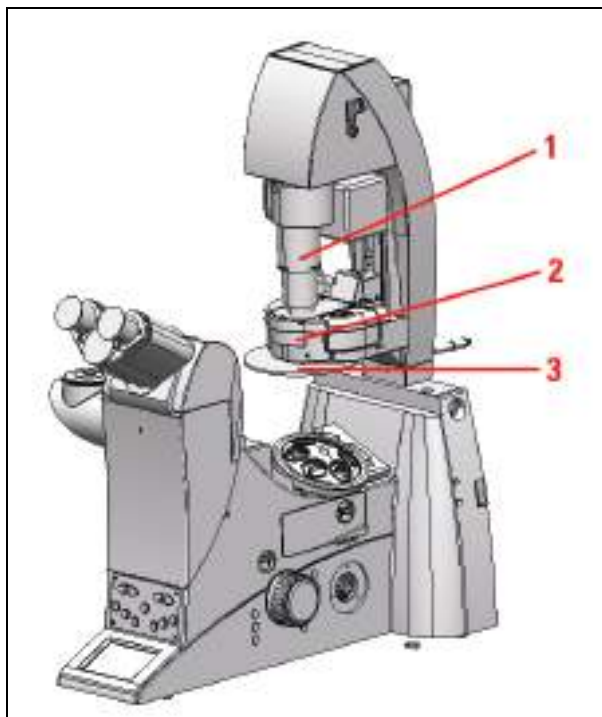

**Figure 48:** Inverted microscope

- 1 Laser Protection Tube
- 2 Condenser Base
- 3 Laser Protection Shield

#### **Reordering a Condenser Base:**

When reordering a condenser base (see **Figure 48, item 2**), be sure to note that the condenser base is supplied without a laser protection shield (see **Figure 48, item 3**).

The existing laser protection shield (see **Figure 48, item 3**) must always be reinstalled. Please consult the microscope's user manual provided.

#### **Condenser Base with Filter Holder:**

When using a condenser base with filter holder, always make sure that unused filter holders are swung out of the beam path, and that the laser protection tube covers the beam path.

When equipping multiple filter holders with filters, do so from bottom to top so that the laser protection tube can cover the beam path to the greatest possible extent. Do not swing in the filters during the scanning operation.

## 11.7.2 Safety Beam Guide on the MP System

The light of all employed VIS lasers (wavelength range 400 - 700 nm, visible spectrum) and UV lasers (wavelength range < 400 nm, invisible) is fed through a fiber optic cable and, therefore, completely shielded until it leaves the microscope objective and reaches the specimen.

For systems with infrared laser (wavelength range > 700 nm), the beam is passed through a safety beam guide and, if necessary, also passed through a fiber optic cable (see **Figure 49**). This completely shields the laser beam until it leaves the microscope objective and reaches the specimen.

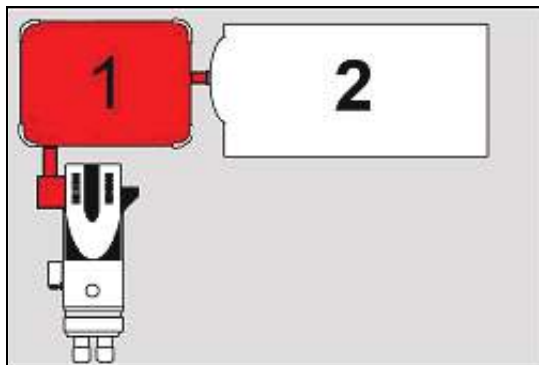

Figure 49: Safety beam guide (1) and IR laser (2)



## 12 Safety Labels on the System

The corresponding safety labels depend on the laser configuration (VIS, UV, MP); they are attached in either English or German at the following locations.

**WARNING Permanent eye and skin damage from failure to observe the safety labels on the system**

Make sure that the safety labels shown in the User Manual are attached to the system.



Safety labels may not be removed.

Missing or damaged safety labels must be attached immediately and at the described location. Operation without the safety labels shown is not permitted. If you have any further questions, contact your laser safety officer or the Leica branch office in your country immediately.

### 12.1 Compact Supply Unit (Only for FLIM)

View of the compact supply unit:

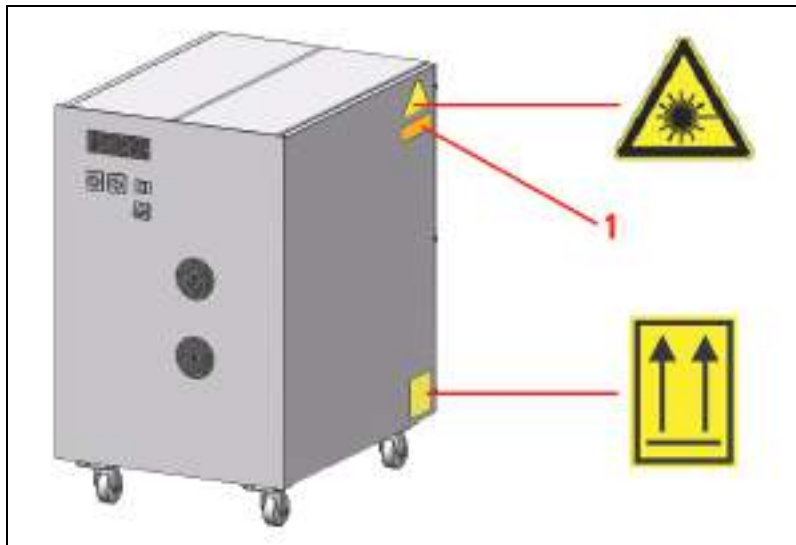

Figure 50: Safety labels on the compact supply unit

Position	Safety label in English	Translation of the safety label
1	DANGER LASER RADIATION CLASS 3B WHEN OPEN AVOID EXPOSURE TO BEAM	VORSICHT LASERSTRAHLUNG KLASSE 3B WENN ABDECKUNG GEÖFFNET NICHT DEM STRAHL AUSSETZEN

Table 8: Safety Labels on the Compact Supply Unit (see Figure 50)

## 12.2 Flexible Supply Unit

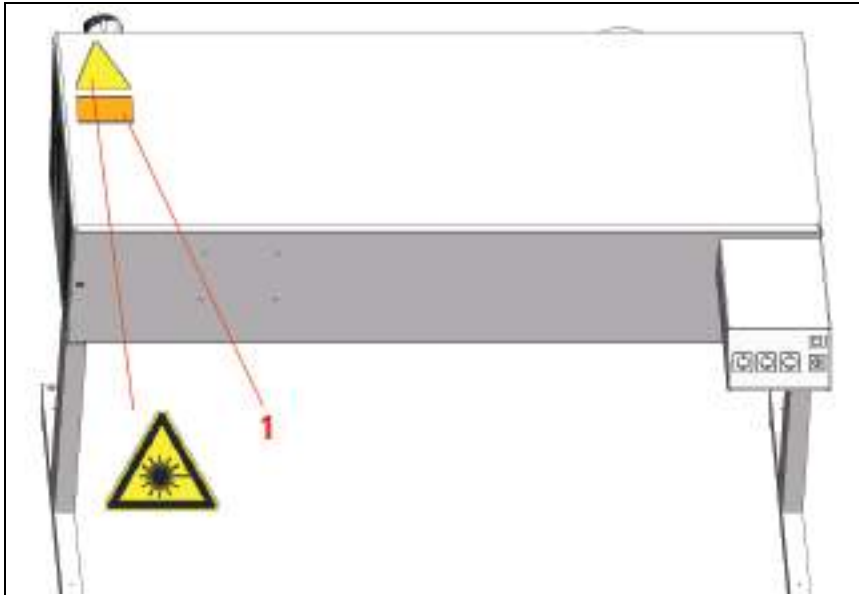

Figure 51: Safety labels on the flexible supply unit

Position	Safety label in English	Translation of the safety label
1	DANGER LASER RADIATION CLASS 3B WHEN OPEN AVOID EXPOSURE TO BEAM	VORSICHT LASERSTRAHLUNG KLASSE 3B WENN ABDECKUNG GEÖFFNET NICHT DEM STRAHL AUSSETZEN

Table 9: Safety Labels on the Flexible Supply Unit (see Figure 51)

## 12.3 Inverted Microscope

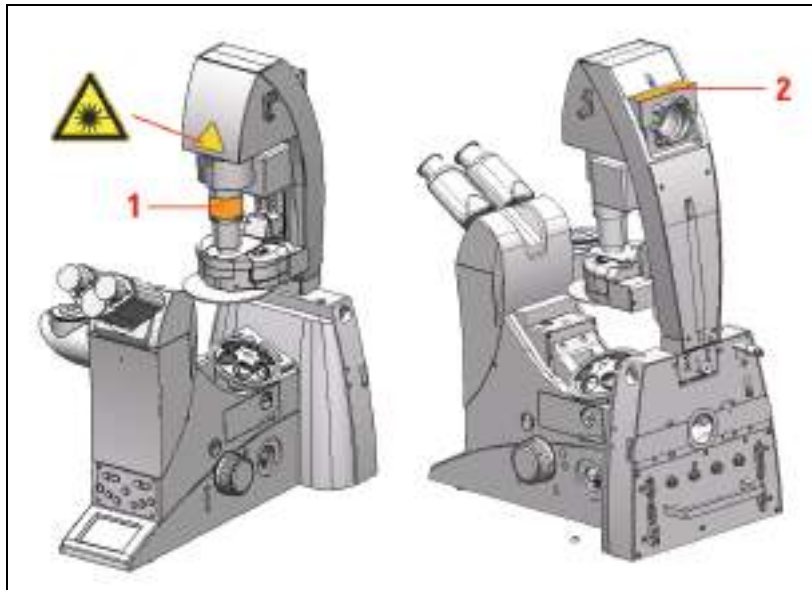

Figure 52: Safety labels for the inverted microscope

Position	System	Safety label in English	Translation of the safety label
1	VIS	LASER RADIATION IS EMITTED FROM THIS APERTURE AVOID EXPOSURE	AUSTRITT VON LASERSTRAHLUNG BESTRAHLUNG VERMEIDEN
	UV/MP	VISIBLE AND INVISIBLE LASER RADIATION IS EMITTED FROM THIS APERTURE AVOID EXPOSURE	AUSTRITT VON SICHTBARER UND UNSICHTBARER LASERSTRAHLUNG BESTRAHLUNG VERMEIDEN
2	VIS	DANGER LASER RADIATION CLASS 3B WHEN OPEN AVOID EXPOSURE TO BEAM	VORSICHT LASERSTRAHLUNG KLASSE 3B WENN ABDECKUNG GEÖFFNET NICHT DEM STRAHL AUSSETZEN
	UV	DANGER VISIBLE AND INVISIBLE LASER RADIATION CLASS 3B WHEN OPEN AVOID EXPOSURE TO BEAM	VORSICHT SICHTBARE UND UNSICHTBARE LASERSTRAHLUNG KLASSE 3B WENN ABDECKUNG GEÖFFNET NICHT DEM STRAHL AUSSETZEN
	MP	DANGER VISIBLE AND INVISIBLE LASER RADIATION CLASS 4 WHEN OPEN AVOID EYE OR SKIN EXPOSURE TO DIRECT OR SCATTERED RADIATION	VORSICHT SICHTBARE UND UNSICHTBARE LASERSTRAHLUNG KLASSE 4 WENN ABDECKUNG GEÖFFNET BESTRAHLUNG VON AUGE ODER HAUT DURCH DIREKTE ODER STREUSTRALUNG VERMEIDEN

Table 10: Safety labels for the inverted microscope (see Figure 52)

## 12.4 Upright Microscope

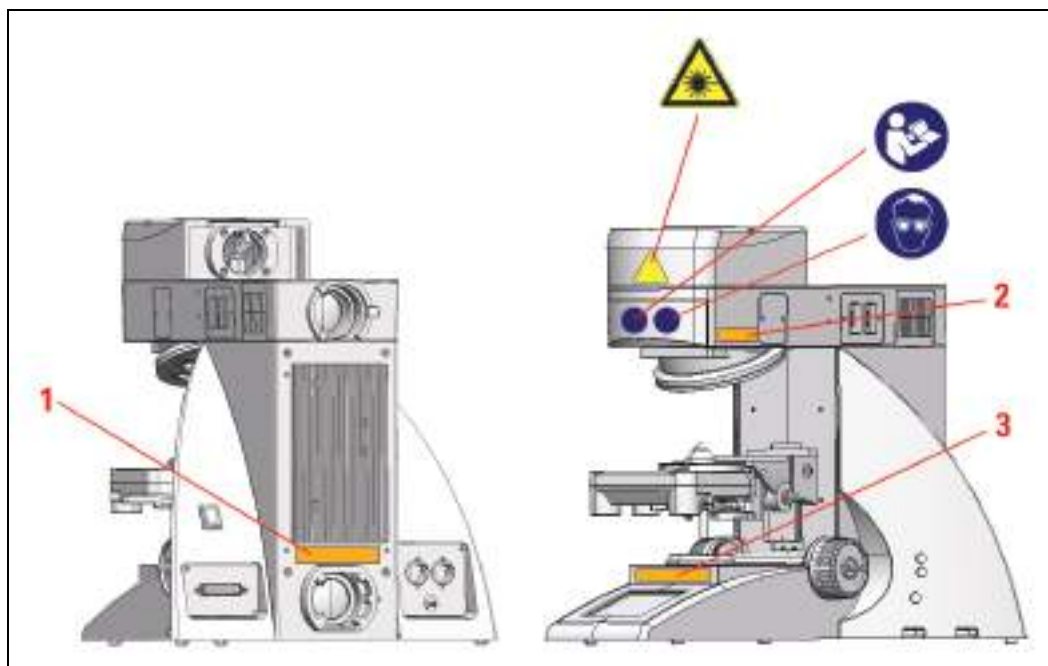

Figure 53: Safety labels for the upright microscope

Position	System	Safety label in English	Translation of the safety label
1	VIS	DANGER LASER RADIATION CLASS 3B WHEN OPEN AVOID EXPOSURE TO BEAM	VORSICHT LASERSTRAHLUNG KLASSE 3B WENN ABDECKUNG GEÖFFNET NICHT DEM STRAHL AUSSETZEN
	UV	DANGER VISIBLE AND INVISIBLE LASER RADIATION CLASS 3B WHEN OPEN AVOID EXPOSURE TO BEAM	VORSICHT SICHTBARE UND UNSICHTBARE LASERSTRAHLUNG KLASSE 3B WENN ABDECKUNG GEÖFFNET NICHT DEM STRAHL AUSSETZEN
	MP	DANGER VISIBLE AND INVISIBLE LASER RADIATION CLASS 4 WHEN OPEN AVOID EYE OR SKIN EXPOSURE TO DIRECT OR SCATTERED RADIATION	VORSICHT SICHTBARE UND UNSICHTBARE LASERSTRAHLUNG KLASSE 4 WENN ABDECKUNG GEÖFFNET BESTRAHLUNG VON AUGEN ODER HAUT DURCH DIREKTE ODER STREUSTRALUNG VERMEIDEN
2 and 3	VIS	LASER RADIATION IS EMITTED FROM THIS APERTURE AVOID EXPOSURE	AUSTRITT VON LASERSTRAHLUNG BESTRAHLUNG VERMEIDEN
	UV/MP	VISIBLE AND INVISIBLE LASER RADIATION IS EMITTED FROM THIS APERTURE AVOID EXPOSURE	AUSTRITT VON SICHTBARER UND UNSICHTBARER LASERSTRAHLUNG BESTRAHLUNG VERMEIDEN

Table 11: Safety labels for the upright microscope (see Figure 53)

## 12.5 Mirror Housing

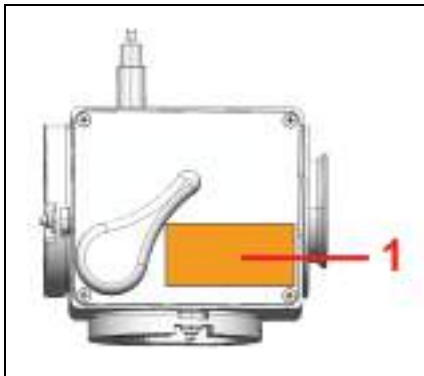

Figure 54: Safety label on the mirror housing (top)

Position	System	Safety label in English	Translation of the safety label
1	VIS	DANGER LASER RADIATION CLASS 3B WHEN OPEN AVOID EXPOSURE TO BEAM	VORSICHT LASERSTRAHLUNG KLASSE 3B WENN ABDECKUNG GEÖFFNET NICHT DEM STRAHL AUSSETZEN
	UV	DANGER VISIBLE AND INVISIBLE LASER RADIATION CLASS 3B WHEN OPEN AVOID EXPOSURE TO BEAM	VORSICHT SICHTBARE UND UNSICHTBARE LASERSTRAHLUNG KLASSE 3B WENN ABDECKUNG GEÖFFNET NICHT DEM STRAHL AUSSETZEN
	MP	DANGER VISIBLE AND INVISIBLE LASER RADIATION CLASS 4 WHEN OPEN AVOID EYE OR SKIN EXPOSURE TO DIRECT OR SCATTERED RADIATION	VORSICHT SICHTBARE UND UNSICHTBARE LASERSTRAHLUNG KLASSE 4 WENN ABDECKUNG GEÖFFNET BESTRAHLUNG VON AUGE ODER HAUT DURCH DIREKTE ODER STREUSTRABLUNG VERMEIDEN

Table 12: Safety label on the mirror housing (see Figure 54)

## 12.6 Cover for Replacement Flange

Front view of the cover:

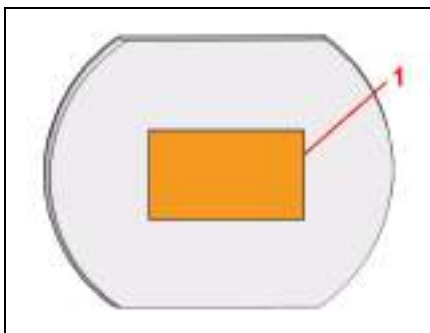

Figure 55: Safety labels on the cover

Position	System	Safety label in English	Translation of the safety label
1	VIS	DANGER LASER RADIATION CLASS 3B WHEN OPEN AVOID EXPOSURE TO BEAM	VORSICHT LASERSTRAHLUNG KLASSE 3B WENN ABDECKUNG GEÖFFNET NICHT DEM STRAHL AUSSETZEN
	UV	DANGER VISIBLE AND INVISIBLE LASER RADIATION CLASS 3B WHEN OPEN AVOID EXPOSURE TO BEAM	VORSICHT SICHTBARE UND UNSICHTBARE LASERSTRAHLUNG KLASSE 3B WENN ABDECKUNG GEÖFFNET NICHT DEM STRAHL AUSSETZEN
	MP	DANGER VISIBLE AND INVISIBLE LASER RADIATION CLASS 4 WHEN OPEN AVOID EYE OR SKIN EXPOSURE TO DIRECT OR SCATTERED RADIATION	VORSICHT SICHTBARE UND UNSICHTBARE LASERSTRAHLUNG KLASSE 4 WENN ABDECKUNG GEÖFFNET BESTRAHLUNG VON AUGEN ODER HAUT DURCH DIREKTE ODER STREUSTRAHLUNG VERMEIDEN

Table 13: Safety Labels on the Cover (see Figure 55)

If the replacement flange for transmitted light is not equipped with a functional module, such as a lamp housing, a cover must be placed over the opening for laser safety reasons.

## 12.7 Transmitted Light Detector (TLD)/Reflected Light Detector (RLD)

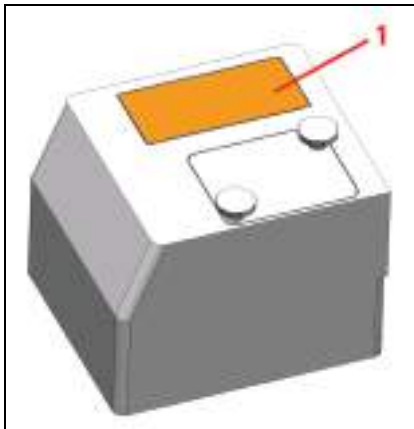

Figure 56: Safety labels on the transmitted light detector or reflection detector with MP systems

Position	Safety label in English	Translation of the safety label
1	DANGER VISIBLE AND INVISIBLE LASER RADIATION CLASS 4 WHEN OPEN AVOID EYE OR SKIN EXPOSURE TO DIRECT OR SCATTERED RADIATION	VORSICHT SICHTBARE UND UNSICHTBARE LASERSTRAHLUNG KLASSE 4 WENN ABDECKUNG GEÖFFNET BESTRAHLUNG VON AUGEN ODER HAUT DURCH DIREKTE ODER STREUSTRAHLUNG VERMEIDEN

Table 14: Safety labels on the transmitted light detector or reflection detector (see Figure 56)

## 12.8 Scan Head

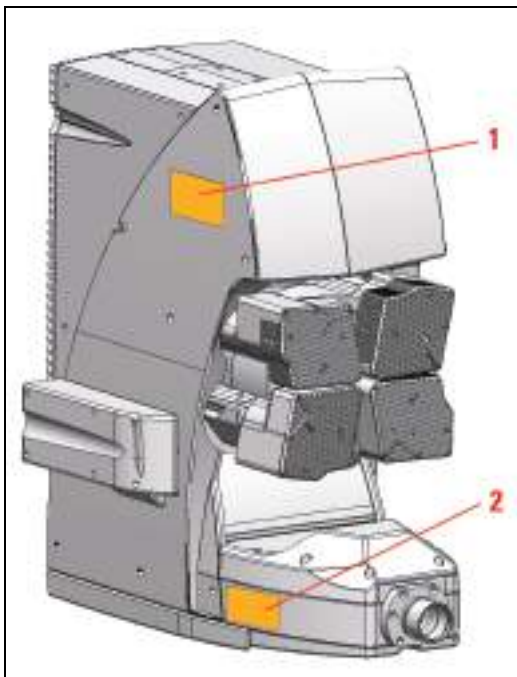

Figure 57: Safety labels on the scan head

Position	System	Safety label in English	Translation of the safety label
1	VIS	DANGER LASER RADIATION CLASS 3B WHEN OPEN AVOID EXPOSURE TO BEAM	VORSICHT LASERSTRAHLUNG KLASSE 3B WENN ABDECKUNG GEÖFFNET NICHT DEM STRAHL AUSSETZEN
	UV	DANGER VISIBLE AND INVISIBLE LASER RADIATION CLASS 3B WHEN OPEN AVOID EXPOSURE TO BEAM	VORSICHT SICHTBARE UND UNSICHTBARE LASERSTRAHLUNG KLASSE 3B WENN ABDECKUNG GEÖFFNET NICHT DEM STRAHL AUSSETZEN
	MP	DANGER VISIBLE AND INVISIBLE LASER RADIATION CLASS 4 WHEN OPEN AVOID EYE OR SKIN EXPOSURE TO DIRECT OR SCATTERED RADIATION	VORSICHT SICHTBARE UND UNSICHTBARE LASERSTRAHLUNG KLASSE 4 WENN ABDECKUNG GEÖFFNET BESTRAHLUNG VON AUGE ODER HAUT DURCH DIREKTE ODER STREUSTRAHLUNG VERMEIDEN
2	VIS	LASER RADIATION AVOID DIRECT EXPOSURE TO BEAM < 500mW 400-700nm CLASS 3B LASER PRODUCT IEC 60825-1: 2007	LASERSTRAHLUNG NICHT DEM STRAHL AUSSETZEN < 500mW 400-700nm LASER KLASSE 3B IEC 60825-1: 2007
	UV	LASER RADIATION VISIBLE AND INVISIBLE - CLASS 3B AVOID DIRECT EXPOSURE TO BEAM < 500mW 350-700nm IEC 60825-1: 2007	LASERSTRAHLUNG SICHTBAR UND UNSICHTBAR - KLASSE 3B NICHT DEM STRAHL AUSSETZEN < 500mW 350-700nm IEC 60825-1: 2007
	MP	LASER RADIATION VISIBLE AND INVISIBLE - CLASS 4 AVOID EYE OR SKIN EXPOSURE TO DIRECT OR SCATTERED RADIATION P< 4W 350-1600nm >80fs IEC 60825-1:2007	LASERSTRAHLUNG SICHTBAR UND UNSICHTBAR - KLASSE 4 BESTRAHLUNG VON AUGE ODER HAUT DURCH DIREKTE ODER STREUSTRAHLUNG VERMEIDEN P< 4W 350-1600nm >80fs IEC 60825-1:2007

Table 15: Safety labels on the scan head (see Figure 57)

## 12.9 White Light Laser

Rear side of white light laser:

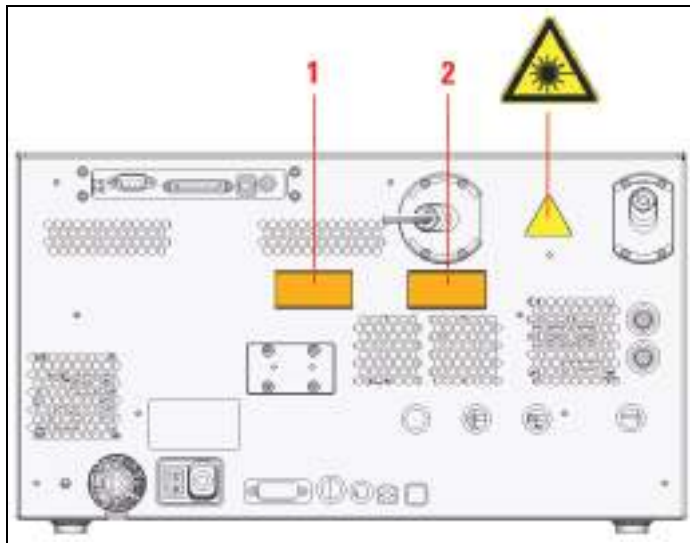

Figure 58: Safety labels on the rear side of the white light laser

Position	Safety label in English	Translation of the safety label
1	DANGER LASER RADIATION CLASS 3B WHEN OPEN AVOID EXPOSURE TO BEAM	VORSICHT LASERSTRAHLUNG KLASSE 3B WENN ABDECKUNG GEÖFFNET NICHT DEM STRAHL AUSSETZEN
2	LASER RADIATION AVOID DIRECT EXPOSURE TO BEAM < 500mW 400-700nm CLASS 3B LASER PRODUCT IEC 60825-1: 2007	LASERSTRAHLUNG NICHT DEM STRAHL AUSSETZEN < 500mW 400-700nm LASER KLASSE 3B IEC 60825-1: 2007

Table 16: Safety labels on the rear side of the white light laser (see Figure 58)

## 12.10 External UV Laser

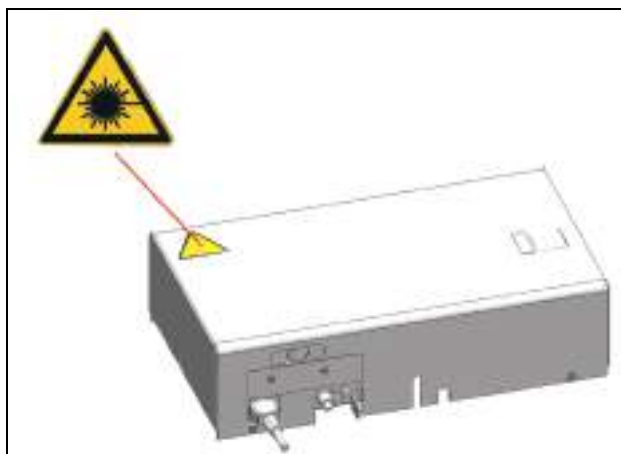

Figure 59: Safety Label on External UV Laser 405

## 12.11 MP Beam Coupling Unit

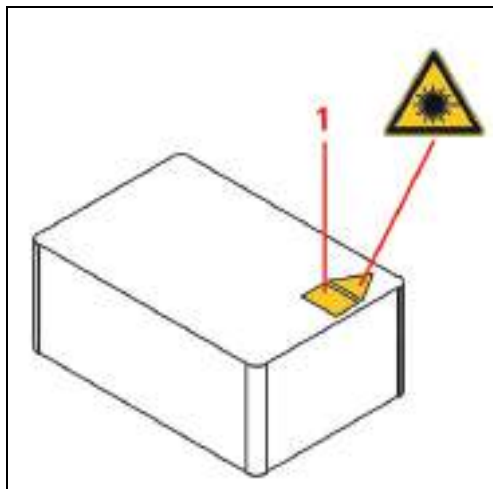

Figure 60: Safety label for the MP beam coupling unit (top side)

Position	Safety label in English	Translation of the safety label
1	DANGER VISIBLE AND INVISIBLE LASER RADIATION CLASS 4 WHEN OPEN AVOID EYE OR SKIN EXPOSURE TO DIRECT OR SCATTERED RADIATION	VORSICHT SICHTBARE UND UNSICHTBARE LASERSTRAHLUNG KLASSE 4 WENN ABDECKUNG GEÖFFNET BESTRAHLUNG VON AUGEN ODER HAUT DURCH DIREKTE ODER STREUSTRABLUNG VERMEIDEN

Table 17: Safety label for the MP beam coupling unit (top) (see Figure 60)

## 12.12 Other External Lasers



### Observe the user manuals for external lasers

Please refer to the information from the documents provided by the laser manufacturer for the external lasers. Pay particular attention to the laser manufacturer's notes!

## 13 Switching On the System

The TCS SP8 SMD is available in different versions. You must precisely follow the switch-on sequence that applies to your system variant. During FLIM experiments, it is also possible to operate the system with a compact supply unit.

### 13.1 Confocal System with Flexible Supply Unit

**NOTICE**    **Damage is possible when contacting the specimen stage**

When using an inverted microscope, the illuminator arm must be swung back before the system start and LAS AF start because the stage can damage the condenser, the objective or the specimen during initialization.

**NOTICE**    **Objective damage is possible when contacting the specimen stage**

When using an upright microscope, the specimen stage must be moved down before the system start and LAS AF start because it could come into contact with the objective during initialization and damage the objective.

1. If you are using a fluorescence lamp EL6000, switch it on first.



Figure 61: EL6000

2. If you are using a HyD RLD, switch it on at its supply unit (see **Figure 80**). You can find additional information on the HyD RLD in **Chapter 13.3**.
3. Switch on the workstation and the microscope on the main switch board of the flexible supply unit (see **Figure 62, item 1**). You do not have to start the operating system—it starts automatically when you switch on the workstation. Wait until the startup process has concluded.

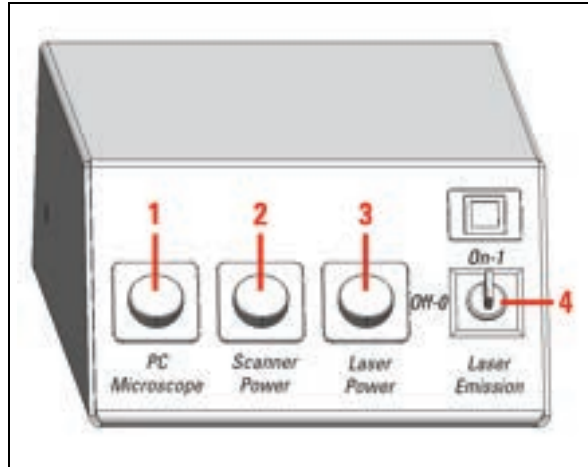

Figure 62: Overview of the main switch board on the flexible supply unit

4. Switch off the multiple socket outlet on the trolley. Switch on the SMD workstation if it does not start up automatically.
5. Check whether the microscope is switched on. The microscope is operational once the readiness indicator (**Figure 63, item 1**) on the toggle switch is lit up. If the readiness indicator is not lit, activate the electronics box toggle switch (**Figure 63, item 2**).

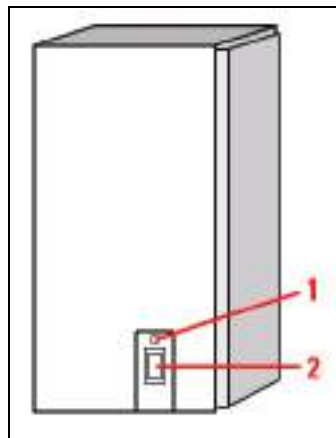

Figure 63: Microscope electronics box

6. If your system has an infrared laser (MP) or an optical parametric oscillator (OPO), switch on the NDD detection unit.

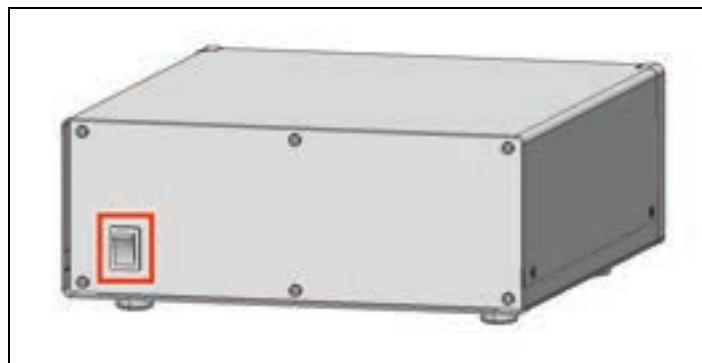
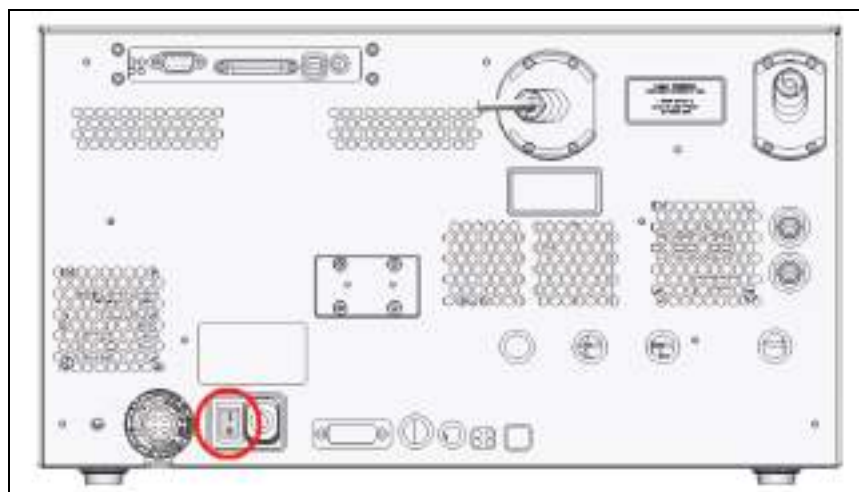

Figure 64: Switch on the NDD detection unit

7. Switch on the scan head on the flexible supply unit's main switch board (see **Figure 62, item 2**).
8. Switch on the lasers on the main switch board of the flexible supply unit (see **Figure 62, item 3**).

The power supplies and fan of the system have now been started.

9. If your system has an infrared laser (MP) or an optical parametric oscillator (OPO), switch on these components as described in the manufacturer's respective user manual.
10. If your system has a white light laser, check whether the white light laser's power supply is switched on: The white light laser's power supply is switched on if the power switch on the rear side of the white light laser is at "On".



**Figure 65:** Power switch on the rear side of the white light laser

11. To switch on the laser in the supply unit, press the key switch on the main switch board of the flexible supply unit (see **Figure 62, item 4**).

**WARNING Risk of permanent eye and skin damage from laser radiation**



From this time on, laser radiation may be present in the specimen area of the laser scanning microscope. Make sure to follow the safety notes for operation of the system.

12. To switch on the white light laser, activate the detachable key switch on the front side of the white light laser:

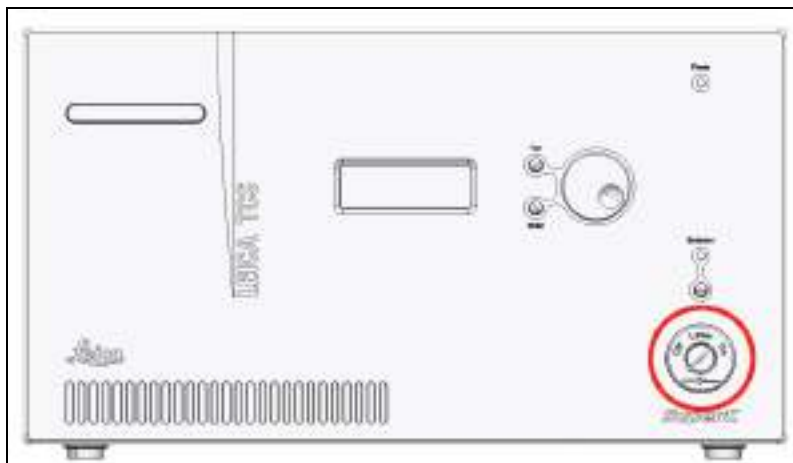

Figure 66: Key Switch for the White Light Laser

### White Light Laser Error Messages



An error report appears in the display of the white light laser.

- if the room temperature exceeds 40°C -> the white light laser switches itself off and can only be turned back on after the room cools off.
- In case of mechanical shock or vibrations -> switch off the white light laser and turn it back on after 10 seconds.

13. If you are using an external 355 and 405 (inclusive) UV laser, make sure that the power switch is in the "On" position (not possible for FLIM, FCS and FLCS images).

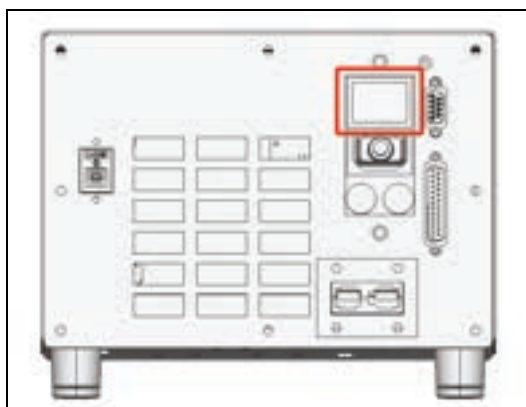

Figure 67: Power switch on external UV laser 355

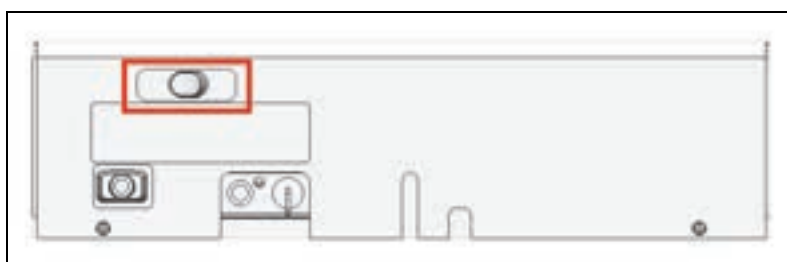

Figure 68: Power switch on external UV laser 405

14. Press the following key switches to switch on the external UV laser 355 including 405:



Figure 69: Key switch on the power supply of external UV laser 355

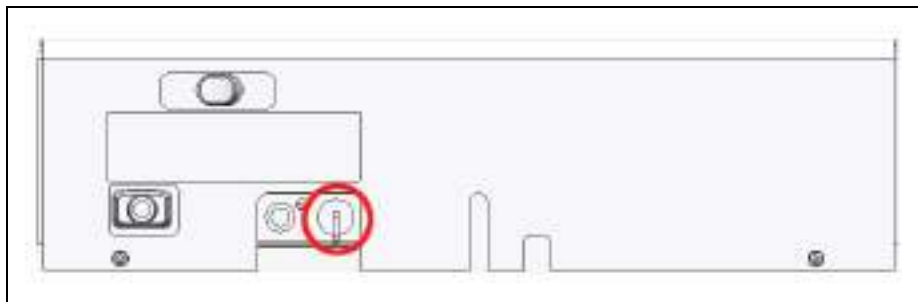

Figure 70: Key switch on external UV laser 405

15. After the workstation has started, log on to the operating system.

#### Using a personalized user ID



Use your personal user ID if one has been set up. This ensures that user-specific settings are saved and maintained for this user only. If the system administrator has not yet assigned a personal user ID, log on as "TCS\_User". The default password is "True!Confocal55".

#### Change password



After logging on with your own user ID, you may change your password. To do so, press the **Ctrl**, **Alt** and **Del** keys at the same time. Then, click **Change password**. The **Change password** dialog box opens.

Now you can start the LAS AF software.

## 13.2 Confocal System with Compact Supply Unit (Only with FLIM)

1. If you are using a fluorescence lamp EL6000, switch it on first.



Figure 71: EL6000

2. If you are using a HyD RLD, switch it on at its supply unit. You can find additional information on the HyD RLD in **Chapter 13.3**.



Figure 72: HyD RLD supply unit

3. Switch on the workstation. The operating system starts automatically. Wait until the startup process has concluded.
4. Switch off the multiple socket outlet on the trolley. Switch on the SMD workstation if it does not start up automatically.
5. Turn on the microscope by actuating the electronics box toggle switch (**Figure 73, item 2**). The microscope is operational once the readiness indicator (**Figure 73, item 1**) on the toggle switch is lit up.

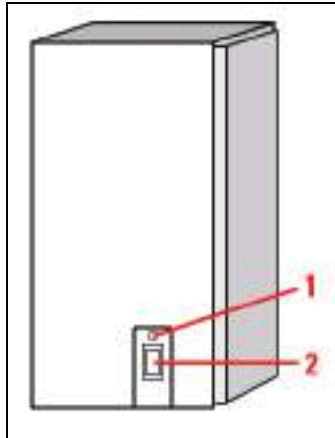

**Figure 73: Microscope electronics box**

6. If your system has an infrared laser (MP) or an optical parametric oscillator (OPO), switch on the NDD detection unit:

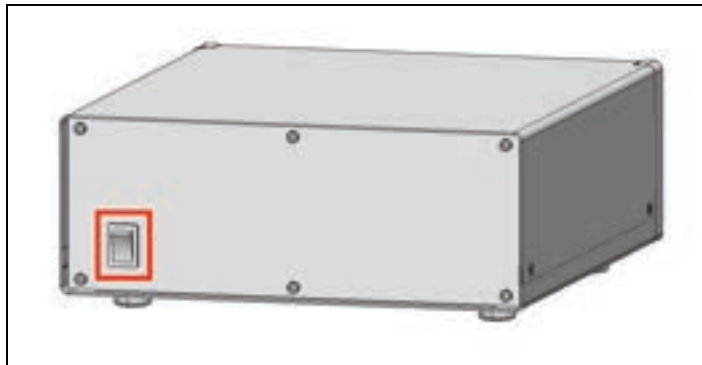

**Figure 74: Switch on the NDD detection unit**

7. Switch on the scan head on the front side of the compact supply unit (see **Figure 75, item 1**).

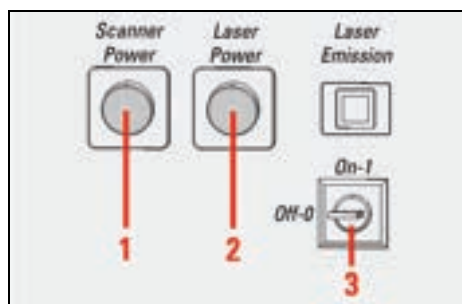

**Figure 75: Overview of the Control Panel Field on the Compact Supply Unit**

8. Switch on the lasers on the front side of the compact supply unit (see **Figure 75, item 2**).

The system's power supplies and fans are started.

9. If your system has an infrared laser (MP) or an optical parametric oscillator (OPO), switch on these components as described in the manufacturer's respective user manual.

10. To switch on the laser in the supply unit, press the key switch on the front side of the compact supply unit (see **Figure 75, item 3**).

**WARNING Risk of permanent eye and skin damage from laser radiation**



From this time on, laser radiation may be present in the specimen area of the laser scanning microscope. Make sure to follow the safety notes for operation of the system.

11. If you are using an external 355 and 405 (inclusive) UV laser, make sure that the power switch is in the "On" position (not possible for FLIM, FCS and FLCS images).

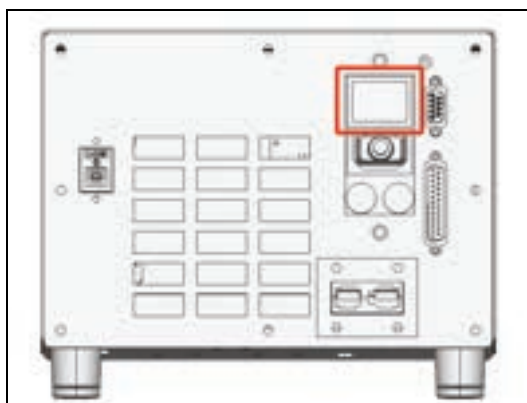

**Figure 76: Power switch on external UV laser 355**

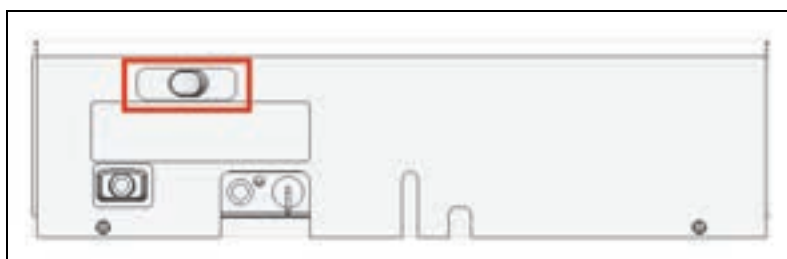

**Figure 77: Power switch on external UV laser 405**

12. Press the following key switches to switch on the external UV laser 355 including 405:



**Figure 78: Key switch on the power supply of external UV laser 355**

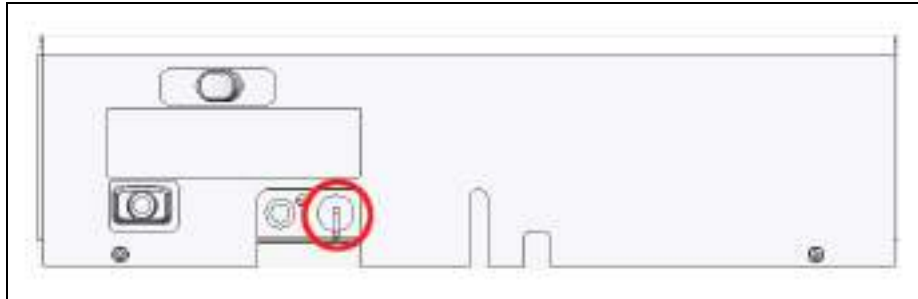

Figure 79: Key switch on external UV laser 405

13. After the workstation has started, log on to the operating system.

#### Using a personalized user ID



Use your personal user ID if one has been set up. This ensures that user-specific settings are saved and maintained for this user only. If the system administrator has not yet assigned a personal user ID, log on as "TCS\_User". The default password is "True!Confocal55".

#### Change password



After logging on with your own user ID, you may change your password. To do so, press the **Ctrl**, **Alt** and **Del** keys at the same time. Then, click **Change password**. The **Change password** dialog box opens.

Now you can start the LAS AF software.

## 13.3 HyD Reflected Light Detectors (HyD RLDs)

- Never change or remove the filter cube or short pass filter during operation.
- The filter cube cover (see **Figure 81, item 1**) ensures the housing's EMC stability and prevents light from entering or exiting.
- Replacement of the short pass filter is only allowed starting from LAS AF Version 2.7 or later.

If you are using HyD RLDs, you have to switch them on before LAS AF starts. Otherwise, the LAS AF software cannot initialize the detectors. The HyD RLDs consist of a supply unit (see **Figure 80**) and a detector module (see **Figure 81**).

The power switch for switching on and off the power supply and the cooling for the detector module is located on the front side of the supply unit (see **Figure 80**).

For image acquisition, activate the detectors in LAS AF. The yellow status LED (see **Figure 81, item 2**) flashes if photons are being detected.



Figure 80: HyD RLD supply unit

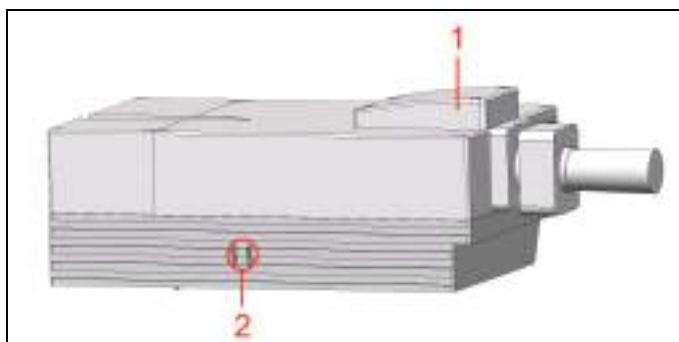

Figure 81: HyD Reflected Light Detectors (HyD RLDs)

Status LED color (see Figure 81, item 2)	Meaning
Green	Operational readiness
Red	The maximum permitted signal level was exceeded. The detector was shutoff.
Yellow	Flashes if photons are being detected.
Blue	Cooling is active.

## 13.4 Starting the SMD Hardware and Software



### Observe the user manuals provided

Always observe all of the user manuals provided for the individual components and peripheral devices.

In the following we assume a running confocal system with the specimen already in place and in focus. The target region for FLIM or FCS measurements has already been determined (**Chapter 15**, **Chapter 18.1.5**, **Chapter 18.1.6** and **Chapter 18.2**). The SMD upgrade can be started completely independently from the Leica TCS SP8.

Start the SMD upgrade hardware and software in the following sequence:

1. Check whether the SMD workstation is started.
2. Make sure that all devices in the trolley are started. If the instruments are not supplied with electricity despite multiple socket outlets being switched on, check whether the

power switch is in the "ON" position.

3. Start the laser driver and switch the laser on. If you are using the PDL 828 Sepia II laser driver, set the key switch to the "ON" position. Prior to data acquisition, the laser head should be operated for a few minutes to stabilize. If you use a PDL 828 Sepia II, start the specific Sepia software on the SMD workstation and set the laser settings there (refer to corresponding manuals).
4. Start the SymPhoTime software on the SMD workstation.
5. Open an existing workspace by selecting **Load Workspace** in the **File** menu or create a new workspace by selecting **New Workspace** in the **File** menu (see SymPhoTime manual).
6. Set the correct fluorescence filter on the corresponding filter holder position of the external PicoQuant detector unit or on the Leica TCS SP8. Select the correct SMD filter cube in the X1 port adapter (**Chapter 23, Figure 188**). If you have a dual-channel APD detector unit, set the variable beam splitter unit to the correct position (see dual channel detector unit manual for details).
7. Be sure that no light falls on the detectors. Either switch on the power supply or, if using a DSN 102 power supply, start the respective detector by selecting the corresponding channel button on the DSN 102.

The SMD upgrade is now ready to use. The communication between the SP8 confocal system itself and the SMD upgrade electronics starts at the beginning of the data acquisition.



## 14 LAS AF

The LAS AF software is used to control all system functions and acts as the link to the individual hardware components. Image acquisition, image analysis and image processing are carried out using LAS AF.

Within the Leica LAS AF software, FCS and FLIM experiments are designed and executed using special Wizards. After data acquisition, the SMD data analysis is carried out within the SymPhoTime (SPT) software by PicoQuant.

### 14.1 Starting LAS AF

**NOTICE**    **Damage is possible when contacting the specimen stage**

When using an inverted microscope, the illuminator arm must be swung back before the system start and LAS AF start because the stage can damage the condenser, the objective or the specimen during initialization.

**NOTICE**    **Objective damage is possible when contacting the specimen stage**

When using an upright microscope, the specimen stage must be moved down before the system start and LAS AF start because it could come into contact with the objective during initialization and damage the objective.

1. Click the LAS AF symbol on the desktop to start the software.
2. Select whether the system is to be operated in resonant (**Resonant: On**) or conventional mode (**Resonant: Off**).



**Figure 82:**    **Selection of resonant or conventional mode**

LAS AF saves the settings for **Configuration**, **Microscope** and **Resonant** as they were set the last time the software was started.

3. Now start LAS AF by clicking the **OK** button.

You are now in the main LAS AF view.

## 14.2 Structure of the Graphical User Interface



**Figure 83: Structure of the Graphical User Interface**

- |   |                          |    |   |
|---|--------------------------|----|---|
| 1 | Scaling range            | 7  | Image display                               |
| 2 | Operating mode selection | 7a | Image display settings                      |
| 3 | Steps                    | 7b | Image processing and image analysis options |
| 4 | Menu                     | 7c | Channel display                             |
| 5 | Tab area                 | 8  | Image acquisition buttons                   |
| 6 | Working area             |    |   |

### Scaling range:

Using the slider, you can modify the (size) display of the user interface. On the right next to the slider, there is a reset button which you can use to reset the scaling to the default setting.

### Operating mode selection:

Here you can set the operating mode you would like to use for image acquisition and analysis independently of your system configuration.

### Steps:

Various steps are available depending on the selected operating mode. The TCS SP8 base module has the following four steps: **Configuration, Acquire, Process, Quantify.**

### Menu:

The **File** and **Help** dropdown menus are located here.

### Tab area:

The displayed tabs depend on the selected step. In the TCS SP8's basic operating mode, the following tabs are assigned to the steps:

- **Acquire** step:  
**Experiments** tab: Directory tree for opened files  
**Acquisition** tab: Hardware settings for the current experiment and parameter settings for image acquisition
- **Process** step:  
**Experiments** tab: Directory tree for opened files  
**Process Tools** tab: Overview of the functions available in this step
- **Quantify** step:  
**Experiments** tab: Directory tree for opened files  
**Tools** tab: Overview of the functions available in this step

#### **Working area:**

Depending on the step and tab selected, different dialogs are available in the working area:

- **Acquire** step:  
**Beam Path Settings:** In this dialog, the beam path is shown schematically. You can select and adjust the lasers and the system components along the beam path and the detectors for image acquisition.
- **Process** step:  
Appropriate processing options and a preview image appear in the working area based on which function you have selected in the **Process Tools** tab.
- **Quantify** step:  
The working area is divided into two tabs:  
**Graphs:** Graphic representation of values that were measured in the entire image or in regions of interest (ROI)  
**Statistics:** Display of statistical values that were determined in the entire image or in plotted regions of interest (ROI)

#### **Image display:**

Acquired images can be displayed and regions of interest (ROI) and additional information can be plotted here.

#### **Image display settings:**

This area contains buttons used to change the display options for acquired images (such as color).

#### **Image processing and image analysis options:**

This area contains buttons that can be used to add information to the image, such as text, arrows or dimensions. In addition, there is a button that enables regions of interest (ROI) to be plotted in the image display.

#### **Channel display:**

Here, you can select how the acquired image is to be displayed. If you have excited your specimen with multiple laser lines, you can use the buttons to select whether the different channels are displayed individually, next to each other or in one image.

#### **Image acquisition buttons:**

These buttons are available to you during the **Acquire** and **Quantify** steps. Here you can

select how the acquisition is to be started:

- **Autofocus:** Focusing using the selected settings
- **Live:** Acquisition of a live image
- **Capture Image:** Acquisition of an individual image
- **Start:** Series of acquisitions using the selected settings

The software's "experiment concept" allows logically interconnected data to be managed together. The **Experiments** tab is displayed in a tree structure in different steps. Experiments are managed there:



Figure 84: View of the Experiments tab

Experiments have an export function for opening images and animations in an external application. The following selection of export formats is available if you select an experiment by right-clicking it:

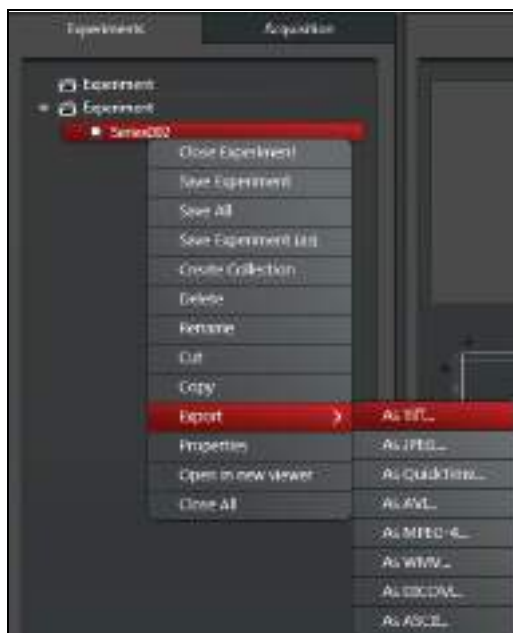

Figure 85: Possible export formats

## 14.3 Design of the FLIM Wizard in LAS AF

The LAS AF software includes a FLIM wizard with operating steps for capturing and optimizing image data as well as a function that enables FLIM measurements to be carried out.

To start the FLIM Wizard, open the operating mode selector and select **FLIM** (Figure 86).



Figure 86: Starting the SMD FLIM Wizard in LAS AF

When the Wizard is opened, the settings for the beam path configured are transferred to the Wizard. They can be further modified within the Wizard.

The basic structure of the FLIM Wizard corresponds to the structure of the LAS AF user interface (see Figure 83). Special features of the Wizard are represented on the following pages.

The Wizard is organized into five steps:

- **Overview** workstep: Here, you can get an overview of the steps additionally contained in the Wizard.



Figure 87: Overview of the FLIM Wizard steps

- **"Setup Corr-ring"** step Some immersion objectives have a correction ring to optimally correct for differences in the refractive index between immersion and specimen and temperature effects. An optimum adjustment of the correction ring correlates with the best possible optical resolution of the system. In the **Setup Corr-ring** step, the beam path is preconfigured for a fast and efficient adjustment of the correction ring.
- **Setup Imaging** workstep: Here, you can establish and optimize the conditions for the acquisition of a reference image. In the **Setup Imaging** step, the FLIM data acquisition cannot be started.
- Step **Setup FLIM**: Here, you can define and optimize instrument parameters for the FLIM measurement. The FLIM measurement instrument parameters (such as selection of the laser line and intensity, image size, pinhole size, etc.) are managed independently of the parameters for image acquisition in the **Setup Imaging** step. The optimal laser intensity can be determined with a FLIM test measurement (selecting the **FLIM Test** button).
- Step **Measurements**: Here, you can define the FLIM experiment (exposure time of the individual FLIM images, definition of FLIM volume stacks, FLIM time series or, for internal SP FLIM, FLIM lambda stacks).

In each step, two to three different tabs are shown in the tab area:

- On the **Experiments** tab, the intensity image data shown on the image display (LAS AF Viewer) is saved. The FLIM data is only saved in the PicoQuant software SymPhoTime.
- On the **Acquisition** tab, you configure the settings for image acquisition such as scan speed, zoom, or pinhole diameter or you can define a stack or time series for FLIM measurements.
- On the **Setup** tab, you can select external or internal detectors for FLIM, run FLIM test measurements, and edit file names and comments.

After completing the FLIM measurements, you can close the Wizard by selecting the **TCS SP8** operating mode (**Figure 88**).



**Figure 88:** Closing the Wizard

## 14.4 Design of the FCS Wizard in LAS AF

The LAS AF software includes an FCS Wizard with steps for capturing and optimizing image data as well as a function that enables FCS measurements to be carried out on previously defined points.

To start the FCS Wizard, open the operating mode selector and select **FCS**(**Figure 89**). The system must not be in resonant mode. If it is, you must restart the software. While doing so, disable the "**Resonant Scanner**" check box after starting LAS AF.



**Figure 89:** Starting the FCS Wizard in LAS AF

When the Wizard is opened, the settings for the beam path already configured are transferred to the Wizard. They can be further modified within the Wizard.

The basic structure of the FCS Wizard corresponds to the structure of the LAS AF user interface (see **Figure 83**). Special features of the Wizard are represented on the following pages.

The Wizard is organized into five steps:

- **Overview** workstep: Here, you can get an overview of the different steps within the Wizard (**Figure 90**).

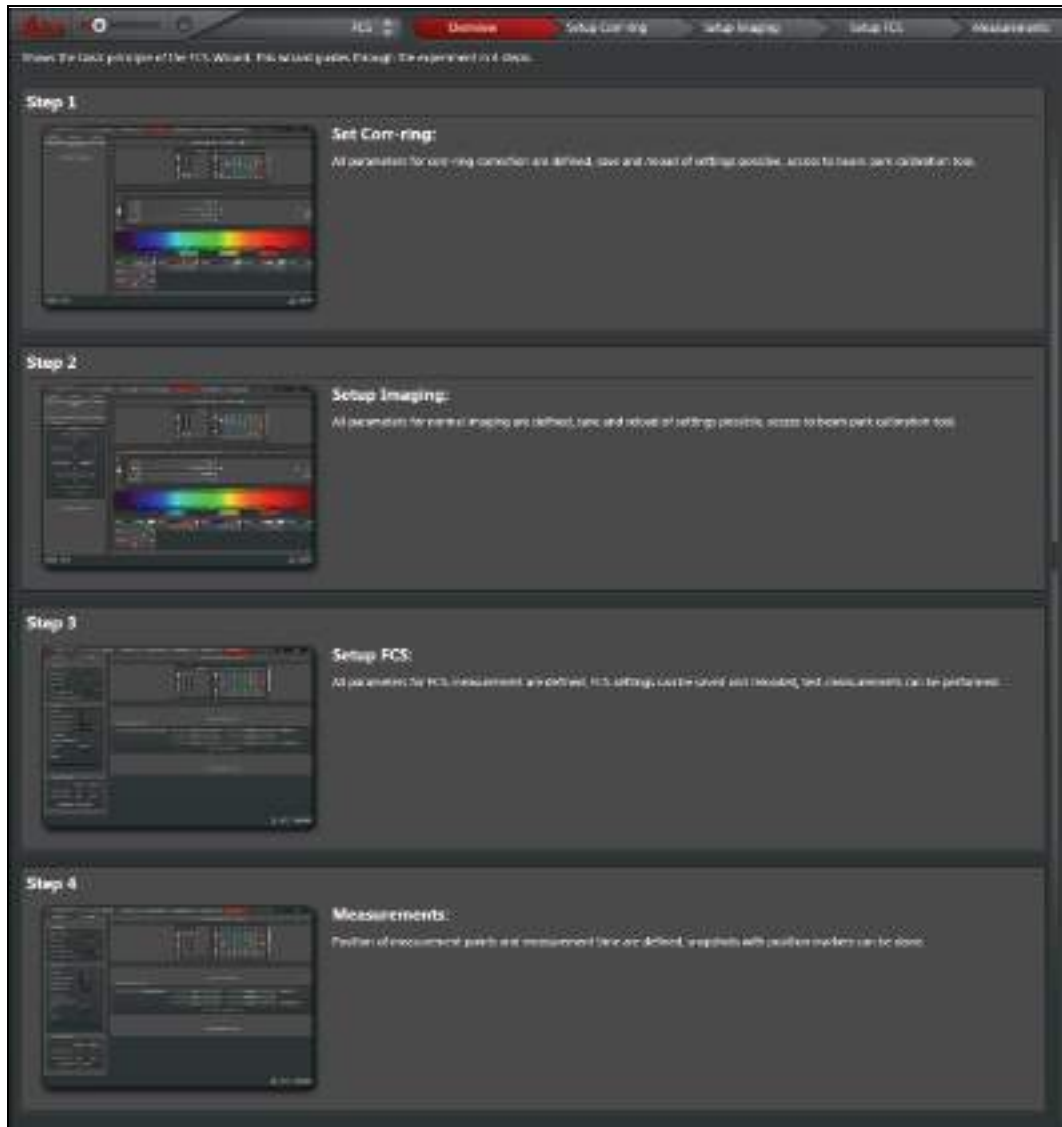

Figure 90: Overview of the SMD FCS Wizard steps

- **"Setup Corr-ring"** step The recommended FCS objective (63x Plan Apo 1.2 W) has a correction ring to optimally correct for differences in the refractive index between immersion and specimen and temperature effects. An optimum adjustment of the correction ring correlates with the best possible optical resolution of the system – a basic requirement for FCS measurements. In the **Setup Corr-ring** step, the beam path is preconfigured for a fast and efficient adjustment of the correction ring.
- **Setup Imaging** workstep: Here, you can establish and optimize the parameters for scan acquisition. This step also includes a semi-automated routine for fine-tuning the park position of the scanner (**Chapter 18.1.2**).
- **Setup FCS** step: Here, you can define and optimize instrument parameters for the FCS measurement. The FCS measurement instrument parameters (such as selection of the laser line and intensity, pinhole size, etc.) are managed independently of the parameters for image acquisition. The FCS settings can also be saved and edited. To optimize the measurement conditions, you can use the crosshair to define an FCS measurement point in the previously acquired xy or xz image or an xyz or xzy stack, and carry out a test measurement there.

- Step **Measurements**: Here, you can define multiple FCS measuring points in the previously acquired xy or xz image or xyz or xzy stack, then carry out consecutive and automatic FCS measurements defined in the **Setup FCS** step. The list of measuring points can be saved and reloaded.

In each step, different tabs are shown in the tab area:

- On the **"Workflow"** tab you will find a suggested workflow and the functions associated with it.
- On the **"Experiments"** tab, the image data are stored.
- On the **Acquisition** tab, you can configure the settings for image acquisition, such as scan speed, zoom or pinhole diameter, or you can define a series of FCS measurements.

In all steps of the Wizard, you can access continuous scanning or acquire a single image or z or y-stack at any time with **"Live"**, **Capture image** and **Start**. The conditions for image acquisition that you defined in **Setup Imaging** are used for this.

### FCS Measurements in Solutions



Even when carrying out FCS measurements in solutions, you have to acquire an xy image before the first FCS measurement. This is necessary so that the scanner can become oriented in the scan field. The information content of this image is not relevant here.

Then, if you carry out the FCS measurement in step **Setup FCS** and do not move the crosshair, the scanner is simply parked in the center of the image.

After the completion of the FCS measurements, you can close the Wizard by selecting the operating mode **TCS SP8 (Figure 91)**.



**Figure 91:** Closing the Wizard

## 14.5 LAS AF Online Help

### 14.5.1 Structure of Online Help

Online Help is divided into seven main chapters:

- **General Information:**  
Contains legal notices and general information on LAS AF.
- **About LAS AF Online Help:**  
Contains general information for the LAS AF Online Help.
- **LAS AF Steps:**  
Contains detailed dialog descriptions for the user interface in LAS AF steps.
- **LAS AF Application Wizards:**  
Contains detailed dialog descriptions for the user interface in LAS AF application wizards and extensive documentation for the MatrixScreener wizard.
- **LAS AF Advanced Time Lapse Modes:**  
Contains detailed dialog descriptions for the user interface in live data mode and in ElectroPhysiology operating mode.
- **LAS AF Express View:**  
Contains a detailed description of the LAS AF express view file browser.
- **Additional Information:**  
Contains background information on topics related to LAS AF, applications and systems, such as digital image processing, dye separation and objective accessories.

### 14.5.2 Accessing Online Help

In the menu bar, click on the **Help** menu. The menu drops down and reveals search-related options, including the following:



Figure 92: Online help menu

- **Contents:** Opens the table of contents for Online Help.
- **Index:** Opens the index for Online Help.
- **Search:** Opens the full-text search function for Online Help.
- **About:** Calls up the **User Configuration** dialog.

### 14.5.3 Selecting the Language for Online Help

By default, English is set as the language for Online Help. In order to select another language, follow these steps:

1. In LAS AF, switch to the **Configuration** step.
2. Click on the **User Config** button on the left side to access the **User Configuration** dialog.
3. In the **User Configuration** dialog, select the desired language under **Help Language**.

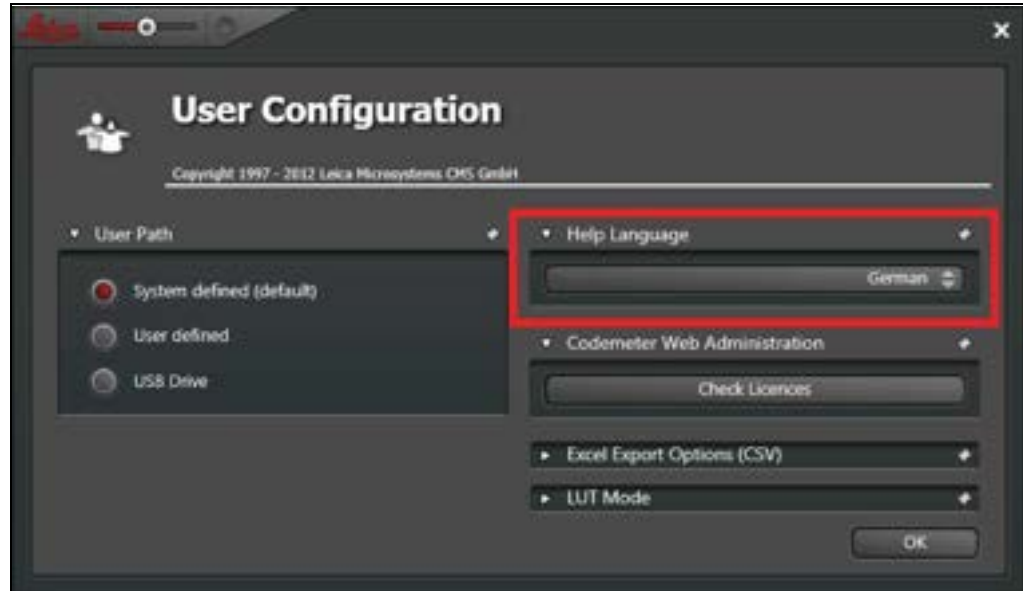

**Figure 93:** Selecting the language for Online Help

The next time you call up Online Help, the help topics will be displayed in the selected language.

The **Help** menu provides a second option for changing the language. Call up the **Help -> About** menu. The **User Configuration** dialog opens and you can select the desired language (see **Figure 93**).

## 14.5.4 Using Online Help

A navigation window is on the left side of the screen in the LAS AF Online Help. It contains three tabs that allow the contents of Online Help to be retrieved in different ways.

- **Contents** tab:  
Contains the table of contents in the form of a directory tree that can be expanded or collapsed. Double-click an entry in the table of contents to display the corresponding information.
- **Index** tab:  
Displays all keywords alphabetically and hierarchically. Double-click on an index entry to display the corresponding information or press the **Display** button.  
You can also search by keyword: Enter the word you would like to search for in the search box. Online help displays the keyword that is the closest match to the specified word.
- **Search** tab:  
Allows full-text searching. Enter the word you would like to search for in the search box. Click on the **List Topics** button. An alphabetically structured list of topics containing the keyword is displayed.

## 14.5.5 Full-text Search with Logically Connected Search Terms

In Online Help, you can use the full-text search function to search for words and for phrases enclosed in quotation marks. You can also use placeholders when searching (such as \* or ?).

You can run a full-text search using logical operators (such as boolean operators) in order to link search terms and thereby increase the accuracy of search results. In the input field on Online Help's **Search** tab, directly input the desired logical operator together with the search terms. The following logical operators are available:

- Excitation **AND** Wavelength:  
Finds help topics that contain both the word "excitation" and the word "wavelength".
- Excitation **OR** Wavelength:  
Finds help topics that contain either the word "excitation" or the word "wavelength" or both.
- Excitation **NEAR** Wavelength:  
Finds help topics where the word "excitation" and the word "wavelength" are located within a specific search radius. This method also looks for words that are similar in spelling to the words specified in the phrase.
- Excitation **NOT** Wavelength:  
Finds help topics that contain the word "excitation" and not the word "wavelength".



## 15 Selecting the Laser

### 15.1 Activate laser as the excitation source in the configuration menu

All available lasers can be used for images of normal image intensity.

The lasers are switched on outside the Wizards in the **TCS SP8** operating mode.

1. To activate a certain laser, select the **Configuration** step in the **TCS SP8 LAS AF** operating mode.
2. Select the **Laser Config** button (**Figure 94**) and enable the desired laser with the allocated check box (**Figure 96**).



Figure 94: LAS AF configuration window

3. You can also query the laser configuration window from a single Wizard. Click on the **+** button in the laser dialog in the **Beam Path Settings** (**Figure 95**). The corresponding laser configuration window (**Figure 96**) opens.



Figure 95: Button to open a laser configuration window

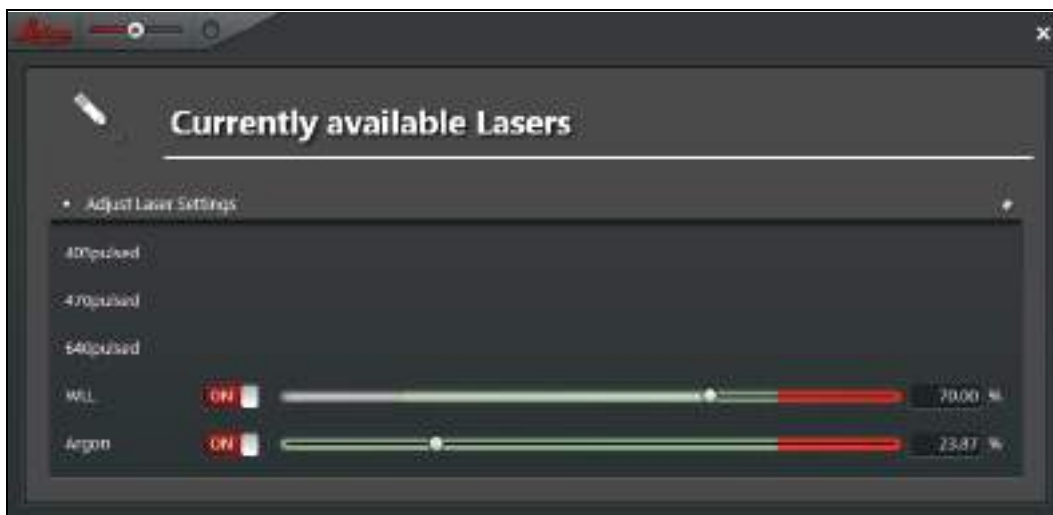

Figure 96: Activate laser in the LAS AF laser configuration window

### 15.1.1 Using Continuous Wave VIS Lasers

1. Open the laser shutter in **Beam Path Settings** (Figure 97, item 1).
2. Set the desired laser line intensity using the slider (Figure 97, item 2).



#### Open shutter

The red-colored **ON** button (Figure 97, item 1) signals that the shutter is open.

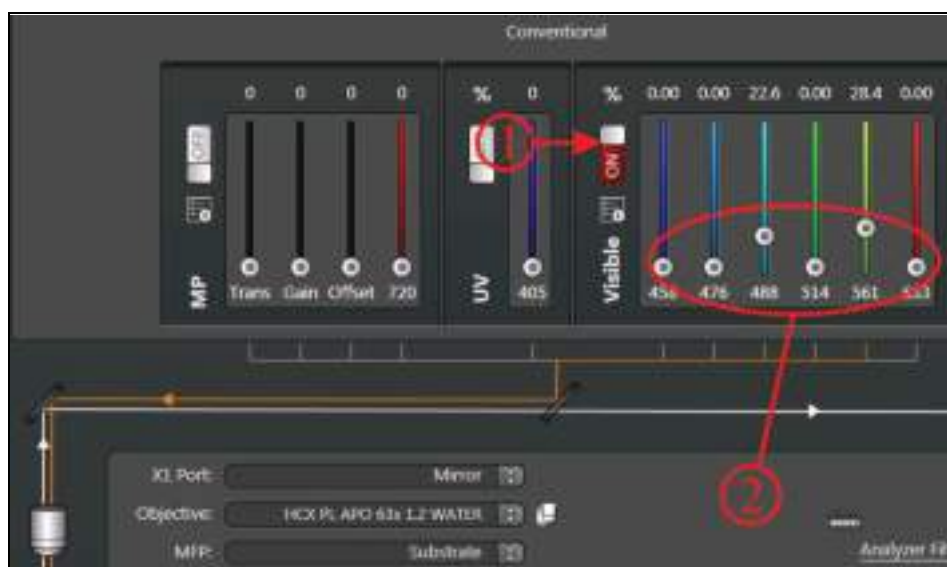

Figure 97: Activating the continuous wave VIS laser in LAS AF

3. On AOBs systems, make sure the acousto-optical beam splitter is in fluorescence mode. Now select the AOBs button to do this (Figure 98, item 2).

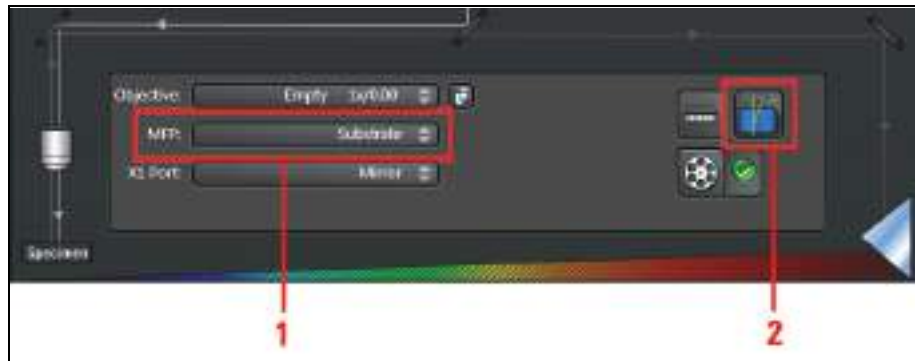

Figure 98: Beam Path Settings: MFP setting (1) and selection of AOBs (2)

4. With beam splitter systems, set the **beam splitter** to one which corresponds to the continuous wave laser line selected for the scan head.
5. If the system has a multifunction port (**MFP**), it should be set to **Substrate** (Figure 98, item 1).

### 15.1.2 Using MP lasers

1. During MP excitation, open the MP laser shutter in **Beam Path Settings** (Figure 99, item 1) and click on the button to open the **MP Laser Configuration** dialog (Figure 99, item 2).

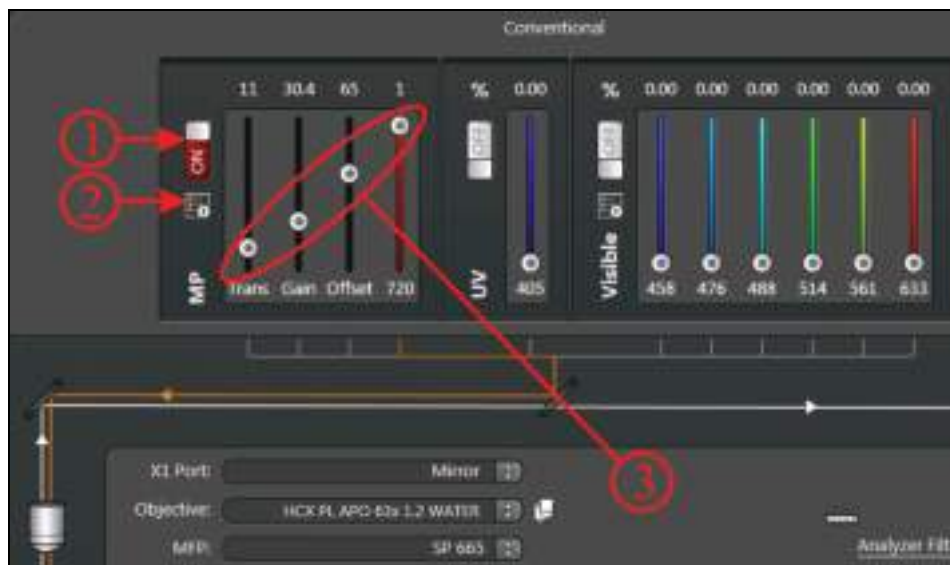

Figure 99: Activating the MP Laser in LAS AF

Use this dialog to open and close the shutter and set the laser wavelength (Figure 102, item 3). **Mode** shows the current status of the laser (Figure 101, item 2).

2. Before using the MP laser, you must open a second shutter on the laser housing (Figure 100) in the **MP Laser Configuration** dialog (Figure 101, item 1). Click on the **MP Shutter** button and hold the mouse button at least two seconds. The selection indicator for the button will turn red (Figure 102).



Figure 100: MP Laser Configuration, second shutter closed

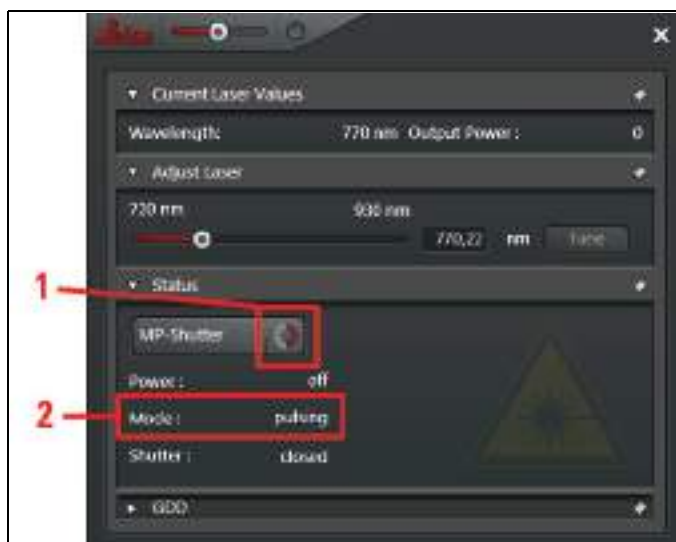

Figure 101: MP Laser Configuration, second shutter opening

**WARNING Risk of permanent eye damage from laser radiation**



The red button signals that the shutter is open and laser radiation can escape. In addition, a laser warning symbol is displayed (Figure 102, item 4).



Figure 102: MP Laser Configuration, second shutter open

3. You can now set the wavelength of the MP laser. Use either the slider (**Figure 102, item 3**) or enter the desired wavelength directly.
4. Select a suitable neutral filter strength for the light incidence (**Trans**) and/or define the **Gain** and **Offset** from the EOM (**Figure 99, item 3**).
5. The position of the multifunction port (**MFP**) should be set to **SP680** or **SP700**.
6. For beam splitter systems, set the **beam splitter** to **substrate** (**Figure 103**).



Figure 103: Setting the beam splitter to substrate

### 15.1.3 Using Pulsed VIS Lasers

1. Switch on the laser driver (PDL 800, SEPIA) as instructed in the corresponding manual.
2. Select **External** as the trigger on the front of the laser driver or, when using a SEPIA II, in the corresponding driver software.
3. Set the intensity to a value between 3.5 and 9 (on the lever on the front side of the PDL driver) or between 35% and 90% (in the SEPIA II software driver).

**Notes about laser intensity**



For intensities under 3.5 (PDL) or 35% (SEPIA II), the pulsed output of the laser light can be interrupted. Do not select too high of values on the laser driver (PDL or SEPIA) unless the laser intensity is not sufficient. High values increase the laser pulse length.

4. Adjust the laser intensity on the laser driver in order to obtain the shortest laser pulse length (see **Chapter 17.12** with respect to measuring instrument response time – "IRF"). In a second step, adjust the laser intensity on the laser or the laser coupling module (LCU) (**Chapter 9.6**), to carry out a corresponding adjustment with respect to the correct fluorescence count rate for FLIM detection.
5. Close the shutter of the continuous wave VIS laser in Beam Path Settings and move all AOTF sliders to the 0 position.
6. Open the shutter for pulsed lasers by turning the button to **ON** (**Figure 104, item 1**).
7. Activate the desired laser by moving the corresponding slider up all the way (**Figure 104, item 2**).

In the control field of the pulsed lasers, the slider setting does not affect the laser intensity. The laser intensity is controlled outside the LAS AF on the laser driver (PDL800, SEPIA) and on the laser coupling module.



**Observe the user manuals provided**

Always observe all of the user manuals provided for the individual components and peripheral devices.

8. Make sure that the multifunction port (**MFP, Figure 104, item 3**) is in the right position (**Table 18**).

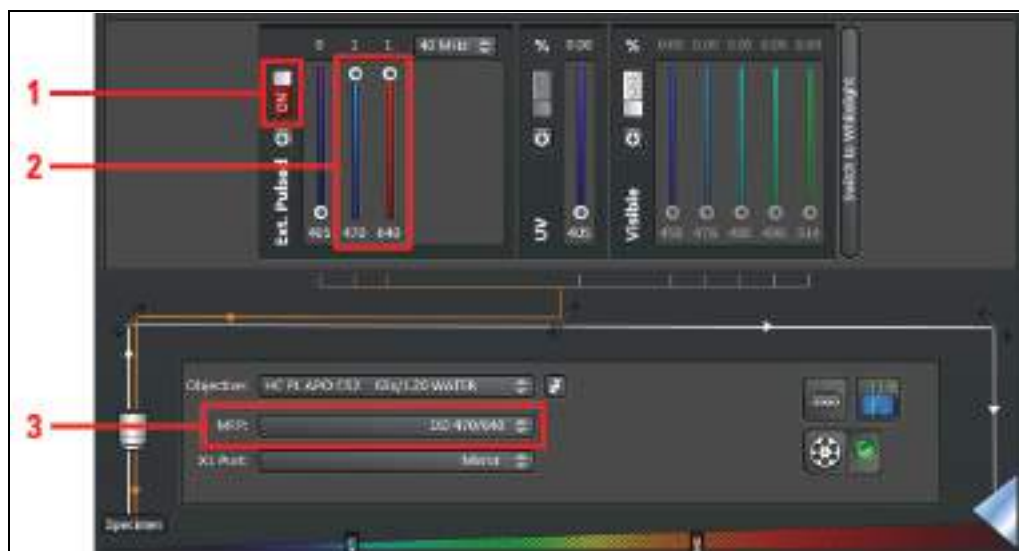

**Figure 104:** Settings for pulsed VIS lasers in Beam Path Settings

Configuration	Lasers used	MFP settings in LAS AF
405	405	Substrate
405+440	405 440	Substrate RSP 445
405+470	405 405+470 470	Substrate SD 470 SD 470
405+470+640	405 405+470 405+640 470 470+640 640	Substrate DD 470+640 DD 470+640 DD 470+640 DD 470+640 DD 470+640
440	440	RSP 445
440+470	440 470	RSP 445 SD 470
470	470	RSP 445
470+640	470 470+640 640	DD 470+640 DD 470+640 DD 470+640

**Table 18: MFP settings based on the excitation wavelength used**

You can use pulsed VIS lasers together with a pulsed UV laser. The MFP setting is not influenced by UV. It is defined by the selection of the pulsed VIS lasers.

**Combination pulsed and continuous wave VIS excitation**



Do not use any pulsed VIS excitation together with continuous wave VIS excitation for continuous wave laser lines close to the wavelengths of the pulsed laser (such as the combination 470 nm pulsed + 488 nm continuous wave), as no optimum MFP setting exists for such a combination.

- If you work on a beam splitter system, set the **beam splitter** to **Substrate** in the **Beam Path Settings** in LAS AF (**Figure 105**). In case you want to use a pulsed laser combined with a continuous wave laser line, chose the corresponding main beam splitter that reflects the continuous wave laser line into the scan head.

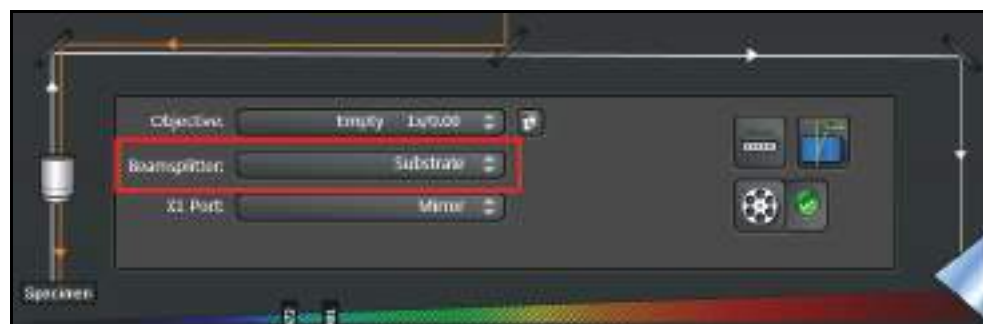

**Figure 105: Setting the beam splitter to substrate**

### 15.1.4 Using Pulsed UV Lasers

1. Open the shutter for pulsed lasers.
2. Activate the 405 nm laser by moving the corresponding slider upwards (**Figure 106, item 1**).

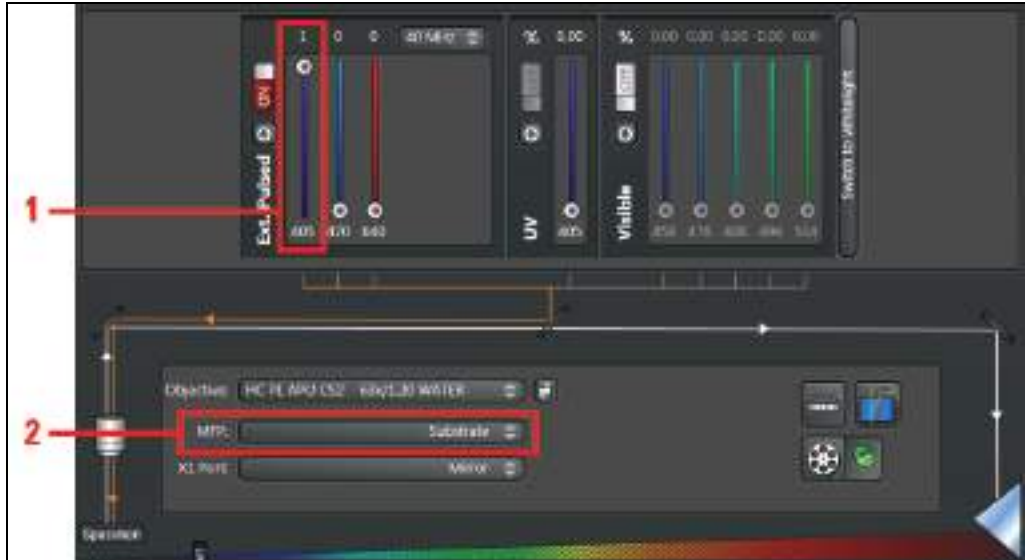

Figure 106: Settings for the UV lasers in Beam Path Settings

3. If no other pulsed laser is used, you can set the multifunction port (**MFP**) to **Substrate** (**Figure 106, item 2**).
4. Follow the settings from **Table 18** if you are using additional pulsed lasers at the same time.

### 15.1.5 Using a Pulsed White Light Laser

1. In the laser dialog in the **Beam Path Settings**, you can switch between the laser spectra for conventional laser lines or the white light laser. In order to call up the laser spectrum of the white light laser, click the **Switch to Whitelight** button (**Figure 107**).

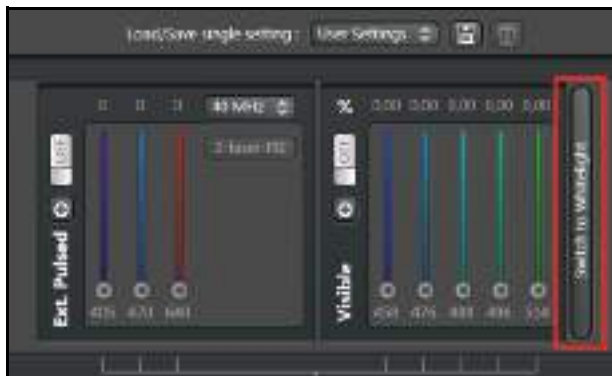

Figure 107: Calling up the white light laser laser spectrum

2. Switch the white light laser to **ON** (**Figure 108, item 1**). The red-colored **ON** button signals that the shutter is open. Then, a laser line appears in the laser spectrum.

3. You can activate up to eight laser lines simultaneously. Click the corresponding buttons (**Figure 108, item 2**).  
The position of the laser lines in the spectrum can be moved as desired.
4. Adjust the power of the line by adjusting the slider for the respective laser line.
5. Select **Constant Power** mode for excitation scans using the white light laser.  
This sets the laser power automatically to 100%.  
When **Constant Percentage** (**Figure 108, item 3**) is selected, work can be done using less power (e.g. 70%).



Figure 108: Adjusting Constant Percentage

6. Then, click on the nearby button (**Figure 108, item 4**) to call up the laser configuration window.
7. In the **Currently available Lasers** dialog, you can set the laser power (**Figure 109**). To do this, enable the laser (**Figure 109, item 1**). Set the desired laser power using the slider (**Figure 109, item 2**).

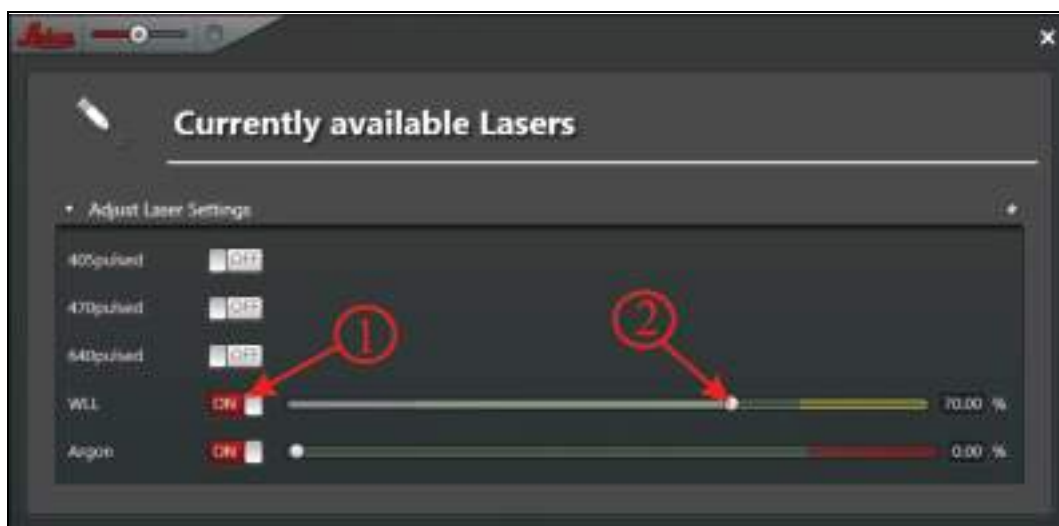

Figure 109: Settings in the Settings menu

### **Automatic MFP positioning**



Within the FLIM Wizard, the MFP positioning is done automatically. MFP positioning occurs at the corresponding beam splitters whenever a laser selection is changed. Outside of the wizard, the user must configure this setting on his or her own.

Settings made automatically can be modified later by the user. These user-defined settings can be saved and reloaded later.

### **Continuous wave mode (cw mode)**



Depending on the configuration, the mode of the pulsed 405 nm laser can be changed to continuous wave mode on the PDL800D or SEPIA II driver (see corresponding manuals). In continuous wave mode, no beam blanking of the laser is active. This means that creating a special region of interest (ROI) and line-by-line sequential scanning do not work!

## 16 FLIM Data Acquisition

You can acquire a FLIM image using a pulsed laser, an internal or external FLIM detector, and an external PicoQuant TCSPC unit.

### 16.1 Setup Imaging Step – Image Acquisition

1. Start the FLIM Wizard in LAS AF. To do so, open the operating mode selector and select **FLIM** (Figure 110).



Figure 110: Selecting FLIM Wizard

2. Open the **Setup Imaging** step.

The scan mode xt and sequential scan are not supported. Except for this, the image acquisition procedure is the same as the general procedure outside the FLIM Wizard.

#### 16.1.1 Selecting Detectors for the Image Acquisition

You can use PMTs or APDs for image acquisition. PMTs are distinguished by having wide dynamic range; APDs are distinguished by higher quantum efficiency.

##### 16.1.1.1 Internal Photomultipliers (Including SP FLIM PMT)

1. In **Beam Path Settings** in the working area, check whether the **Mirror** option is set to **X1 Port**. If not, open the pull-down menu for X1 Port and select **Mirror** (Figure 111).

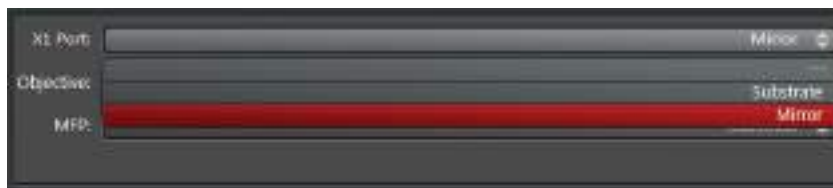

Figure 111: Selecting the Mirror setting for X1 Port

2. In **Beam Path Settings**, enable the desired photomultiplier by clicking the corresponding button (Figure 112, item 1).
3. When a detector is activated, it can be recognized by a shadow with a slider below the electromagnetic spectrum. This slider adjusts the wavelength range detected by the detector (Figure 112, item 2).



Figure 112: Selecting detector and wavelength range in Beam Path Settings

4. If the system has SP FLIM detectors, the **FLIM** option is displayed for the respective detector in **Beam Path Settings** and you can use SP FLIM detectors for the image acquisition.

When you activate **FLIM** (switch is at **ON** – Figure 113, item 1), the **Gain** of the detectors is automatically set to a value of 990 V.

When switched to **OFF** (Figure 113, item 2), the detector can be used for normal image acquisition. You can also adjust the gain of the detectors as usual.



Figure 113: Selecting the operating mode of the internal SP FLIM detectors in Beam Path Settings

5. For multi-channel image acquisition you can use the default image acquisition PMTs (Figure 114, item 1) along with the SP FLIM photomultipliers (Figure 114, item 2).

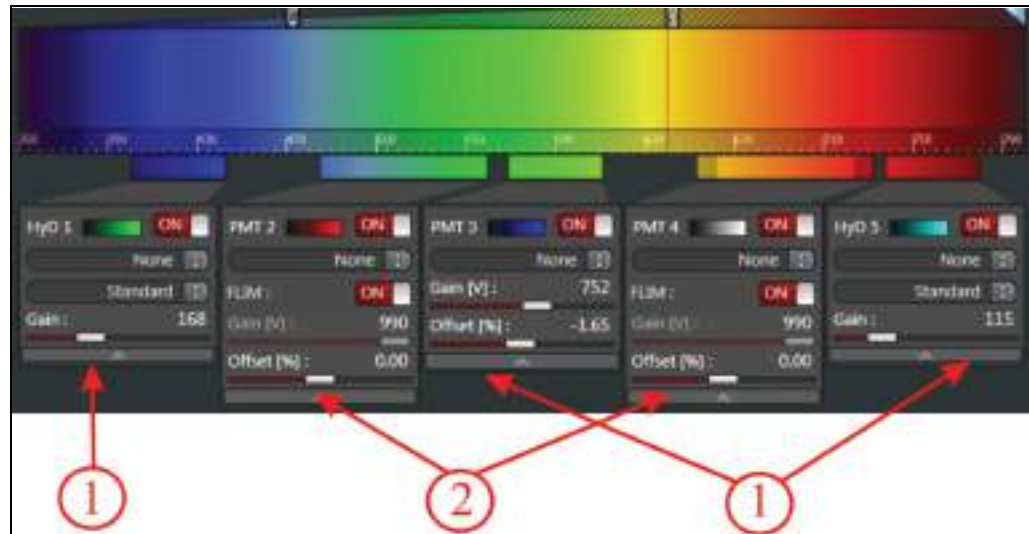

Figure 114: Beam Path Settings of LAS AF when using detectors for default image acquisition (1) and internal FLIM detectors for intensity image acquisition (2)

6. Acquire an image by clicking the **Capture Image** image acquisition button or acquire a stack by clicking the **Start** image acquisition button. The start and finish of the stack are defined interactively. The stack image is automatically added to your LAS AF experiment.

### 16.1.1.2 External APDs

1. First, switch on the APDs electrically.
2. Set **X1 Port** in **Beam Path Settings** in the working area to --- (Figure 115, item 1).



Figure 115: Acquiring the reference image using APDs

3. Deactivate all PMTs.
4. Activate the APDs by clicking the corresponding buttons (**Figure 115, item 2**).



#### Dependency of the spectral detection range of the APDs

The spectral detection range of the APDs is determined by the SMD filter cube used, not by the slider settings for the photomultipliers.

5. Select low laser intensities.
6. You may also have to adapt the color look-up table (LUT). In the dialog of the respective detector, click the color scale to call up the **LUT Selection** dialog. There, you can select color look-up tables (LUT) for displaying the images to be acquired and create user-defined color look-up tables.  
You can also configure the intensity setting via **Gain** and the control panel. This function has no effect on the detector; it modifies the color look-up table, which renders low-intensity structures more visible. It may also be helpful to accumulate over several images. The **Offset** setting on the control panel has no effect on the image.
7. Optimize the image quality. The functions for this are the same as outside the wizard.
8. Acquire an image by clicking the **Capture Image** image acquisition button or acquire a stack by clicking the **Start** image acquisition button. The start and finish of the stack are defined interactively. The stack image is automatically added to your LAS AF experiment.

### 16.1.1.3 External FLIM Photomultiplier



#### Images of the external FLIM PMT only in SymPhoTime

The signal of the external FLIM PMT is not displayed in LAS AF. You can view images created by this detector only in SymPhoTime. The corresponding detector displayed in LAS AF is a simulator required for the function of the wizard.

1. For light to fall on the detector, select the --- option for **X1 Port**.
2. You can enable the **PMT Extern** option in **Beam Path Settings**. It is required for automated functions in the FLIM Wizard (**Setup FLIM** and **Measurements** steps). Activating it causes empty images to be created in LAS AF.

## 16.1.2 Selecting Laser Lines as an Excitation Source for Image Acquisition

All available lasers can be used for the image acquisition. You will find a description of the mode of operation in **Chapter 15**.

### 16.1.2.1 Using Continuous Wave Lasers

1. For capturing the emitted fluorescence, set the acousto-optical beam splitter to fluorescence (**Figure 116**).



Figure 116: Dialog for AOBS configuration

2. Choose a suitable laser line and adjust the intensity to the desired level using the AOTF slider.
3. If the system has a multifunction port (**MFP**), set it to **Substrate**.

### 16.1.2.2 Using MP Lasers

#### Prevent light incidence during MP FLIM measurement



During an MP FLIM measurement (particularly with HyD RLD), the light in the room should be switched off and the shutter of the fluorescence lamp should be closed. Furthermore, the iris diaphragm on the condenser should be completely closed.

1. For MP scanning operations, select the desired wavelength in **Beam Path Settings**.
2. Choose a suitable neutral density filter for the attenuation using the **Trans** slider and/or adjust the electro-optical modulator (EOM) using the **Gain** and **Offset** sliders.
3. If the system has a multifunction port, it should be set to **SP680** or **SP700**.

For more detailed information about switching on the MP lasers, refer to **Chapter 15.1.2**.

### 16.1.2.3 Using Pulsed VIS Lasers

1. Close the shutter of the continuous wave VIS laser in **Beam Path Settings** and move all sliders to the 0 position.
2. Open the shutter for pulsed lasers by activating the corresponding button (**Figure 117, item 1**).
3. Activate the desired laser by moving the corresponding slider upwards (**Figure 117, item 2**).



#### Controlling laser intensity of the pulsed laser

For pulsed lasers, the slider does not affect the laser intensity. Laser intensity needs to be controlled at the desired laser.

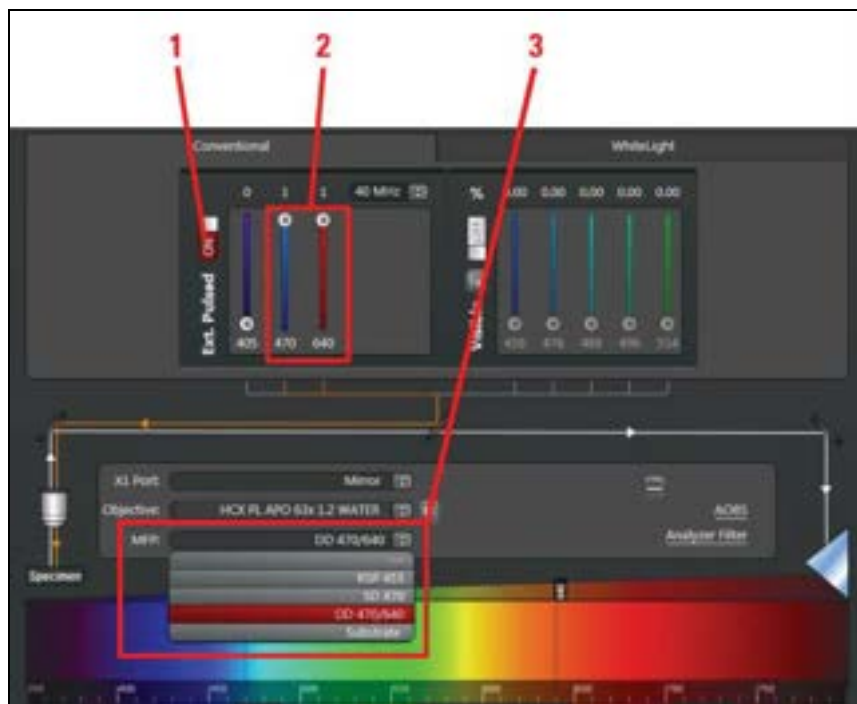

Figure 117: Settings for using pulsed VIS lasers as excitation source

4. Check whether the correct beam splitter (**MFP**) is selected (**Table 18**).

You can use the pulsed VIS lasers together with the pulsed UV laser (405 nm). The MFP setting is not influenced by the UV laser. It is defined by the selection of the pulsed VIS lasers.

#### Combination pulsed and continuous wave VIS excitation



Do not use any pulsed VIS excitation together with continuous wave VIS excitation for continuous wave laser lines close to the wavelengths of the pulsed laser (such as the combination 470 nm pulsed + 488 nm continuous wave), as no optimum MFP setting exists for such a combination.

### 16.1.2.4 Using Pulsed UV Lasers

1. Open the shutter for pulsed lasers by activating the corresponding button.
2. Activate the 405-nm laser by moving the corresponding slider.
3. If no other pulsed laser is used, you can set the multifunction port (**MFP**) to **Substrate**.



#### Positioning the multifunction port

Within the FLIM Wizard, positioning of the multifunction port is automated; outside the wizard, it must be set by the user. The automatic configuration can be changed subsequently by the user.

For more detailed information about using the pulsed UV laser, refer to **Chapter 15.1.4**.

### 16.1.2.5 Using White Light Lasers

1. Select the desired laser lines in the **Whitelight** dialog in **Beam Path Settings**.
2. Make sure that the AOBS is at fluorescence.
3. Set the desired intensity using the AOTF slider.
4. If the system has a multifunction port (**MFP**), it should be set to **Substrate**.
5. Open the **Acquisition** tab and adjust the rotation of the scan field to 0° using the slider (**Figure 118, item 1**).

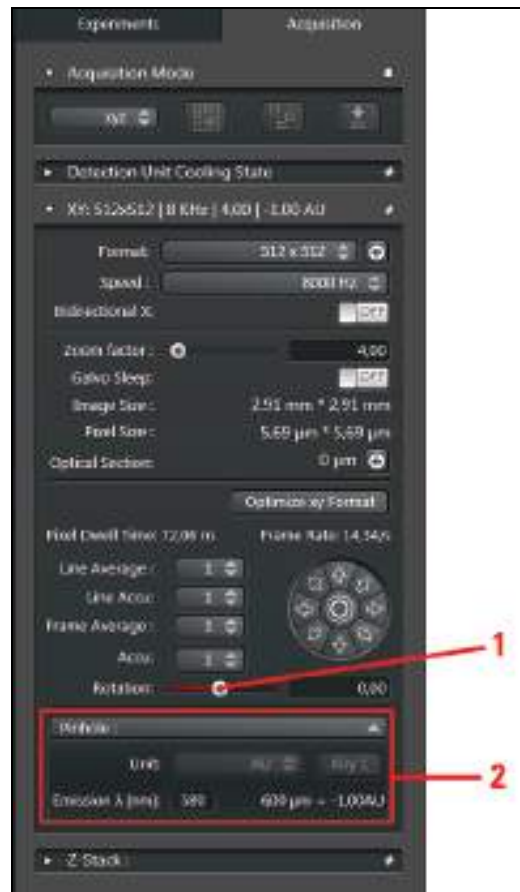

Figure 118: Adjusting the diameter of the pinhole and rotation of the scan field

### 16.1.3 Adjusting the Pinhole for Image Acquisition

For VIS and UV excitation, set the **Pinhole** diameter to **1 Airy**; for MP excitation set it to the maximum size (**Figure 118, item 2**).

## 16.2 Setup FLIM Step – Optimizing the FLIM Measurement Conditions

Go to the **Setup FLIM** step in the FLIM Wizard. Now set the instrument parameters for a FLIM measurement.

### 16.2.1 Selecting FLIM Detectors

For FLIM measurements, special detectors have to be used that are able to do single photon counting with a high time resolution. With FLIM excitation in the UV and VIS range, FLIM detectors are used in a descanned position: The light is either split off at the X1 port to APDs or a FLIM photomultiplier (external detection) or sent to the SP detection module on the SP FLIM photomultiplier (internal detection). With MP excitation, FLIM detectors may optionally be used at a non-descanned position. When doing so, the fluorescent light on the stand is split off directly behind the objective. The following options are available:

- External FLIM detection using two APDs
- External FLIM detection using a FLIM PMT
- Internal FLIM detection using one or two SP FLIM PMTs
- External FLIM detection using two APDs and internal FLIM detection using two SP FLIM PMTs; the internal and external detectors can only be used in alternation for this
- Detection at NDD position with one or two HyD RLD

If you use a system with both internal and external FLIM detection, first you have to select the detectors you want to use:

1. Select the **Setup** tab (**Figure 119**).
2. In the **FLIM Detector** pull-down menu, select either **Internal (SP FLIM)** for internal SP FLIM detection, **External** for external detection at the X1 port, or **Non-descanned (MP FLIM)** for detection at an NDD position (**Figure 119**).



Figure 119: Setup FLIM step

Whenever you toggle between these options, the split-off filter on the stand and the X1 port are automatically moved to the correct position and the corresponding detectors are activated.

If there are pulsed diode lasers in your system, this selection also impacts the automatic adjustment of the fluorifier disc (if present), according to **Table 19, page 143**.

The value displayed in the **Count Rate Monitor** is the count rate of the automatically selected detectors (thus the APDs for external FLIM, the SP FLIM detectors for internal FLIM, and the HyD RLD for NDD FLIM). Detectors that have been activated but not used display a dark count rate, whereas detectors that have not been switched on or activated display the number **0**.

You can change the automatically applied settings later.

FLIM data is collected on the separate SMD workstation using the SymPhoTime software and the FLIM image is displayed there. In addition, if APDs or SP FLIM detectors are used, an intensity image is generated in the LAS AF software during the collection of FLIM data.

### 16.2.1.1 FLIM Data Acquisition with Internal SP FLIM Detectors

For a 5-channel system with a single internal SP FLIM detector, the detector should be at position 4; two internal FLIM detectors should occupy positions 2 and 4 (**Figure 120**). These settings have been preconfigured and cannot be changed by the user. SP FLIM detectors can be used for normal intensity image acquisition (**Chapter 16.1.1**) as well as FLIM data acquisition.

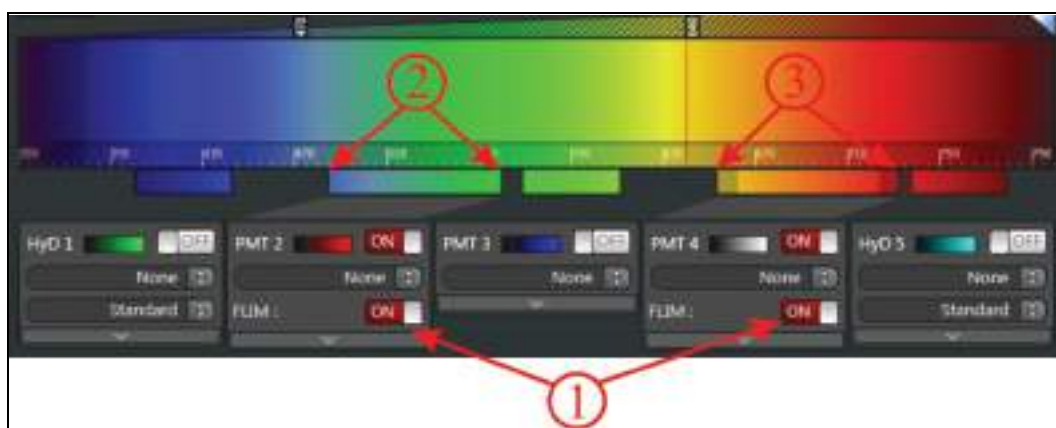

**Figure 120:** Beam Path Settings in LAS AF for internal FLIM data acquisition. Other detectors may also be activated at the same time.

Proceed as follows to prepare the TCS SP8 for the collection of SP FLIM data:

1. Open the **Setup** tab.
2. In the **FLIM Detector** pull-down menu, select the **Internal (SP FLIM)** option (**Figure 119**). The SP FLIM detector should be automatically activated in the **FLIM** mode. If the SP FLIM detector has been deactivated by the user in the meantime, it can be activated by clicking the **ON** button (**Figure 120, item 1**).

Then the FLIM detector goes into **FLIM** mode. A **Gain** of 990 V suitable for FLIM data

acquisition is applied to the detectors. In other words, the gain cannot be changed as long as **FLIM** is selected.

3. Select a suitable range for spectral detection by adjusting the spectral sliders of the SP FLIM detectors accordingly (**Figure 120, item 2 and 3**).

At the same time, additional detectors can be activated and used for intensity image acquisition. The data of these additional detectors is used for the intensity image acquisition, but not for FLIM.

4. If you do not obtain an image, check that the X1 port is in the **Mirror** position.
5. Check to ensure that the fluorifier disc is in a suitable position that blocks excitation light (see **Chapter 16.2.3**).

#### Overload protection for internal SP FLIM detectors

If too much light strikes a FLIM detector, it is temporarily switched off to prevent damage and automatically switched back on after a few seconds. If the detector count rate is not reduced, the detectors will continuously switch off and back on, resulting in horizontal streaks in the image.



The overload protection of the internal FLIM detectors is active in FLIM mode and image acquisition mode. To avoid streaking, reduce the detector count rate. This can be done in a number of ways:

- Reduce the laser intensity
- Reduce the **Gain** (possible in image acquisition mode only)
- Reduce the **Pinhole**
- Use specimens with less intensive fluorescent dye

#### 16.2.1.2 FLIM Data Acquisition with External MPD APDs

Proceed as follows to prepare the TCS SP8 for collecting FLIM data using external APDs:

1. Switch the APDs on electrically.
2. Select a suitable spectral range for the detection by choosing the appropriate SMD filter cube and mount it in the X1 port adapter (see **Chapter 23**).
3. Open the **Setup** tab.
4. In the **FLIM detector** pull-down menu, select the **External** option (**Figure 121, item 1**). In **Beam Path Settings**, the APDs should be selected automatically (**Figure 121, item 2**).

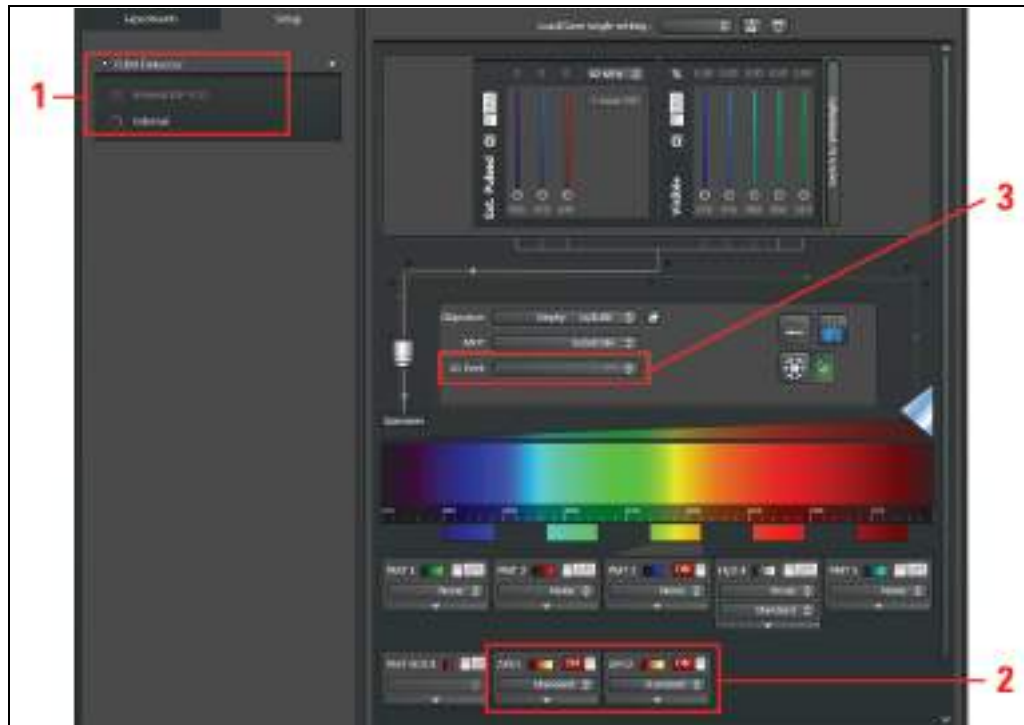

Figure 121: Selecting external APDs for FLIM data acquisition

5. If the APDs still have not been activated in **Beam Path Settings**, click the buttons allocated to the APDs and set them to **ON**.



#### Dependency of the spectral detection range of the APDs

The spectral detection range of the APDs is determined by the SMD filter cube used, not by the slider settings for the photomultipliers.

6. Deactivate the internal photomultipliers. Internal photomultipliers cannot be used for imaging simultaneously with APD detection.
7. If no image is displayed, check whether the --- option is set at **X1 Port (Figure 121, item 3)**.
8. Activate at least one detector (APD), even if no image in LAS AF is required. If no detector is activated in LAS AF at all, it will not be possible to start a scanning operation.



#### Overload protection for external APDs

APDs are deactivated when emission intensity gets too high. MPD APDs (SPADs) have to be manually reactivated. To do so, refer to the corresponding manuals of the APD unit or the DSN. PE APDs activate automatically. Reduce the incident light on the APD.

### 16.2.1.3 FLIM Data Acquisition with External Photomultiplier

Proceed as follows to prepare the TCS SP8 for the collection of FLIM data using an external photomultiplier:

1. Switch on the photomultiplier electrically.
2. Select a suitable range for spectral detection by choosing the appropriate SMD filter

cube and mount it in the X1 port adapter (**Chapter 23**).

In LAS AF, a simulator photomultiplier is activated. This means that no image from the external photomultiplier will be displayed in LAS AF.



#### Dependency of the spectral detection range of the photomultiplier

The spectral detection range of the photomultiplier is determined by the SMD filter cube used, not by the slider settings for the photomultipliers.

3. Internal photomultipliers cannot be used for image acquisition simultaneously with external PMT detection. Deactivate the internal PMTs in LAS AF.
4. If no FLIM image is displayed in the SymPhoTime software, check whether the --- option is set at **X1 Port (Figure 121, item 3)**.



#### Activating the external PMT

Since the signal from the external FLIM PMT is not transferred to the TCS SP8, only a black intensity image is displayed in LAS AF. Despite this, let the external detector remain activated. If no detector is selected at all, it will not be possible to start a scanning operation.

### 16.2.1.4 FLIM Data Acquisition with Detectors at NDD Position (HyD RLD)



#### Prevent light incidence during MP FLIM measurement

During an MP FLIM measurement (particularly with HyD RLD), the light in the room should be switched off and the shutter of the fluorescence lamp should be closed. Furthermore, the iris diaphragm on the condenser should be completely closed.

HyD RLD can only be used if the excitation occurs via an MP laser. They can be used for the intensity image acquisition in LAS AF as well as for the FLIM data acquisition in SymPhoTime.

Follow these steps for FLIM data acquisition:

1. Switch the HyD RLD on as described in **Chapter 13.3** before starting the scanner and LAS AF. Observe this sequence, since otherwise the cooling for the detectors is not initialized.
2. Select a suitable spectral range for detection by choosing the appropriate NDD filter cube and mounting it in the NDD detection unit.
3. Go to the **Setup** tab in the **Setup FLIM** step.
4. In the **FLIM Detector** dialog, select the **Non-descanned (MP FLIM)** option. In **Beam Path Settings**, the HyD RLD should be selected automatically. If that is not the case, activate the detectors in **Beam Path Settings** with **ON (Figure 122)**.



Figure 122: Selecting external HyD RLD for FLIM data acquisition



#### Dependency of the spectral detection range of the HyD RLD

The spectral detection range of the HyD RLD is determined by the NDD filter cube used, not by the slider settings for the photomultipliers.

5. Deactivate the internal detectors. Internal spectral detectors cannot be used simultaneously with HyD RLD.
6. If no image is displayed, check on the stand display whether a decoupling mirror from the stand is in the **RLD/TLD** position. If not, set the filter cube on the stand to this position.
7. Activate at least one detector, even if no image in LAS AF is required. If no detector is activated in LAS AF at all, it will not be possible to start a scanning operation.



#### Overload protection for HyD RLD

HyD RLDs are temporarily deactivated when emission intensity gets too high. They switch back on automatically the next time a scan starts. Beforehand, reduce the incident light on the detector.

**Cooling of HyD RLDs:** To achieve the minimum dark count rate and thereby optimum performance, the HyD RLDs are actively cooled. You can read the cooling status in the **Setup** tab in the **Detection Unit Cooling State** dialog (**Figure 123**). The colors here mean:

- Red: Detector is warm
- Yellow: Detector is cooling now
- Green: Detector has reached its optimum operating temperature



**Figure 123:** Cooling status of the HyD RLD

#### Safety shut-off of the cooling system



The cooling system has a safety shut-off: If the humidity is too high, the cooling system switches off to prevent condensation from forming on the detector.

## 16.2.2 Selecting Laser Lines for FLIM

### 16.2.2.1 Do Not Use Continuous Wave VIS Lasers



#### Use pulsed lasers for FLIM data acquisition

For FLIM, only pulsed lasers can be used. Continuous wave laser excitation must be disabled, since it disrupts the FLIM data acquisition.

Close the corresponding shutter (**Figure 124, item 1**) for continuous wave lasers in **Beam Path Settings** and move all AOTF slider settings to 0 (**Figure 124, item 2**).

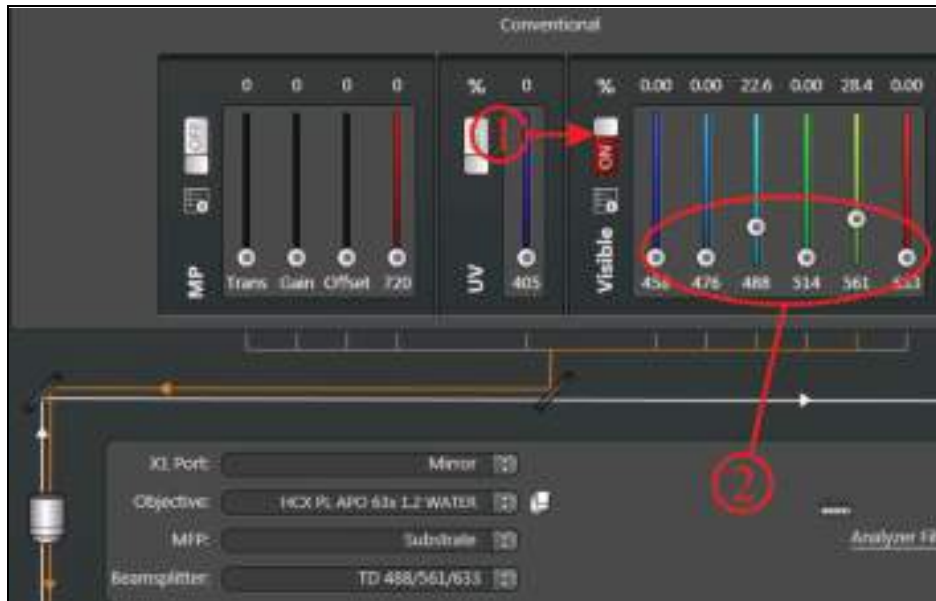

Figure 124: Beam Path Settings in LAS AF: Activating the continuous wave VIS lasers

If the system has an FCS filter wheel, its setting is irrelevant for FLIM, as it is directly in front of the argon laser and thus does not affect the pulsed excitation.

### 16.2.2.2 Using Pulsed Diode Lasers (UV, VIS)

- For external FLIM with APDs or an external photomultiplier: Follow the instructions in **Chapter 15.1**. The fluorifier disc can be set to **Empty** as needed. If additional suppression of the excitation light is desired, follow the recommended settings in **Table 19**.
- For internal SP FLIM with SP FLIM detectors: Check the setting of the fluorifier disc. It contains an additional barrier filter that prevents excitation light from hitting the SP detection module. Recommended settings are given in **Table 19** in **Chapter 16.2.3**.

### 16.2.2.3 Using MP Lasers

#### Prevent light incidence during MP FLIM measurement



During an MP FLIM measurement (particularly with HyD RLD), the light in the room should be switched off and the shutter of the fluorescence lamp should be closed. Furthermore, the iris diaphragm on the condenser should be completely closed.

- For external FLIM at the X1 port and for internal FLIM: Follow the instructions in **Chapter 15.1**. With the fluorifier disc, an MP filter block has to be selected (SP680 or SP700); the pinhole should be open as far as possible.
- For FLIM detection at NDD position (HyD RLD): The setting of the fluorifier disc, X1 port, and **pinhole** play no role.

**Alternative selection of UV and MP FLIM excitation**

Some systems feature both a pulsed diode laser (405 nm) and an MP laser. Only one of these two lasers can be used for FLIM at a time. Make sure that the correct synchronization cable is connected to the TCSPC unit PicoHarp 300 at channel 0. When changing between MP and 405 nm excitation for FLIM, you must also change the synchronization cable connected to the PicoHarp.

**No additional pulsed laser 470 or 640 for MP systems**

Systems equipped with an MP laser cannot be complemented with a pulsed 440, 470, or 640-nm laser.

### 16.2.2.4 Using White Light Lasers

1. To activate the laser, follow the instructions in **Chapter 15.1**. In general we recommend using the filters available in the fluorifier disc.
2. If the white light laser is used as an excitation source for FLIM measurements, always use only one wavelength per FLIM measurement.

**Alternative selection of excitation from a white light laser, pulsed diode, or MP FLIM**

Some systems feature not only a white light laser, but also a pulsed laser and/or an MP laser. Only one of these three laser options can be used for FLIM at a time. Make sure that the correct synchronization cable is connected to the TCSPC unit PicoHarp 300 at channel 0. When changing between MP, white light laser, or diode laser for FLIM, you must also change the synchronization cable connected to the PicoHarp.

### 16.2.3 Adjusting the Fluorifier Disc

With the **Show Fluorifier Settings** button (**Figure 125**), you can call up the **Fluorifier Disc Settings** dialog to select a barrier filter or set a polarization angle.

#### 16.2.3.1 Setting for SP FLIM

SMD systems equipped with SP FLIM detectors have a fluorifier disc with barrier filters for the excitation light. These filters prevent reflected excitation light from hitting the SP module.

Recommended settings of the fluorifier disc for SP FLIM detection:

	Excitation laser line	Recommended setting of the fluorifier disc
1	405	Barrier filter 405/640
2	405+470	Barrier filter 405/470
3	405+ 640	Barrier filter 405/640
4	470	Barrier filter 405/470
5	470+640	Barrier filter 470/640
6	640	Barrier filter 405/640 or 470/640
7	MP	SP680 or SP700
8	WLL	Depending on the selected white light laser wavelength, there are barrier filters for: 488, 514, 561, 594, or 633

**Table 19: Recommended settings for Fluorifier disc for SP FLIM**

As long as the Fluorifier Disc **Auto Select** is active in the dialog window, the position of the Fluorifier disc is automatically set. It can be changed by the user if **Auto Select** is disabled. To do so, proceed as follows:

1. In **Beam Path Settings**, click on the **Fluorifier Disc** button (Figure 125).

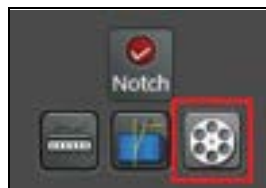

**Figure 125: Fluorifier Disc button in Beam Path Settings**

The following dialog box opens:



**Figure 126: Fluorifier Disc Settings**

2. Click the upper radio button (**Figure 126, item 1**).
3. Filter selection:
  - For automatic filter selection: Select the **Auto Select (Figure 126, item 3)** check box. Individual filters now cannot be manually selected.
  - For manual filter selection: Remove the check in the **Auto Select** check box. From the filter list, select the suitable filter.

### 16.2.3.2 Setting for External FLIM or Intensity Image Acquisition

For external FLIM detection or normal intensity image acquisition, it is possible to use the **Empty** position (**Figure 126, item 2**) as needed in the **Fluorifier Disc Settings**. Remove the check in the **Auto Select** check box and select **Empty** in both menus.

Alternatively, if the effect of polarization is to be investigated, the lower radio button can be clicked (**Figure 126, item 4**) and the polarization direction defined by moving the slider position.

### 16.2.3.3 Setting for FLIM White Light Laser

If the white light laser is used as an excitation source, it is recommended - independent of the detectors used - to use the filters of the fluorifier disc and, thereby, to select the corresponding laser wavelengths (usually 488, 514, 561, 594, and 633 nm, **Figure 127**).

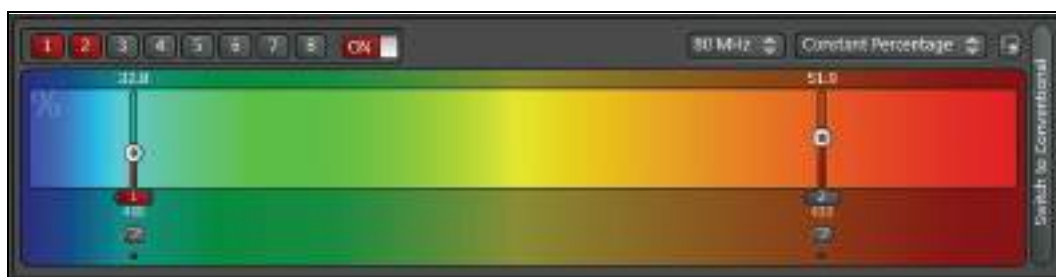

Figure 127: Selecting the laser lines for FLIM white light lasers

Selection switches to set the laser wavelength and the filter wheel can be found in the **Setup FLIM** and **Measurements** steps on the **Acquisition tab (Figure 128)**.



Figure 128: Selection switches to set the laser wavelength and the filter wheel when using the white light laser

If you would like to use other wavelengths for excitation, the filter wheel should be in the **Empty** position (**Figure 126, item 2**).

### 16.2.4 Changing the Pulse Frequency for Pulsed Diode Lasers (405, 440, 470, 640 nm)

The frequency is controlled using LAS AF. The corresponding signal is transferred from the scan head via the pulse interface to the laser driver PDL or Sepia.

1. Make sure that the laser driver is set to external trigger.
2. In **Beam Path Settings**, in the area for controlling the pulsed lasers, select the desired frequency in the pull-down menu (**Figure 129**). The default setting is 40 MHz.

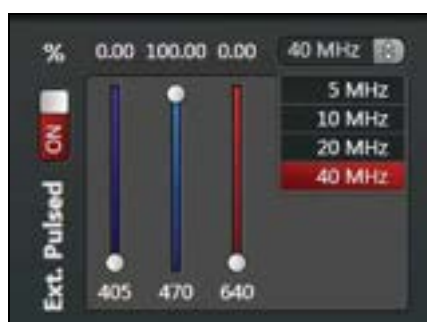

**Figure 129:** Beam Path Settings in LAS AF: Activating a pulsed diode laser and selecting the laser pulse rate.

After changing the frequency, it may be necessary to change the time resolution of the data acquisition in SymPhoTime. You can change the resolution in the oscilloscope window of the SymPhoTime software as follows:

3. Select **Show Oscilloscope...** in SymPhoTime.

The following window is displayed:

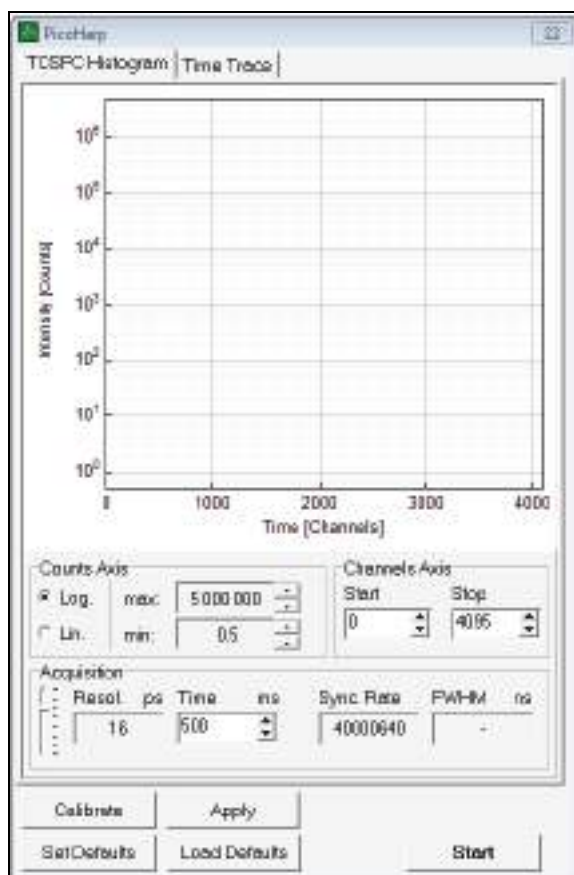

Figure 130: Oscilloscope window in SymPhoTime

- In the **Acquisition** field, you can change the resolution under **resol**. Please confirm the settings by selecting **apply**. To cover the whole range between two consecutive laser pulses at the maximum resolution possible, the following settings are recommended:

Laser frequency	Resolution of data acquisition
80 MHz (MP laser, white light laser)	4 ps
40 MHz (pulsed diode laser, white light laser)	8 ps
20 MHz (pulsed diode laser, white light laser)	16 ps
10 MHz (pulsed diode laser, white light laser)	32 ps
5 MHz (pulsed diode laser)	64 ps

Table 20: Recommended resolution for data acquisition with different laser frequencies

The default is a setting of 16 ps suitable for a laser repetition rate down to 20 MHz.

## 16.2.5 2-Laser PIE (405, 470, 640 nm)

PIE (pulsed interleaved excitation) means that two lasers pulse alternately. This method is used to identify crosstalk and cross excitation and remove them from the signal. In the SMD system, this option is available for certain combinations of pulsed diode lasers (405+470, 405+640, 470+640). Exactly two diode lasers have to be selected in order to activate 2-laser PIE. If this is not the case, the corresponding radio button is grayed out.

Enable the PIE function by clicking on the **2-laser PIE (Figure 131)** button.

Select the base frequency in the pull-down menu. The frequency of both lasers is shown as a **PIE frequency (Figure 132)**, it is half as high as the base frequency.

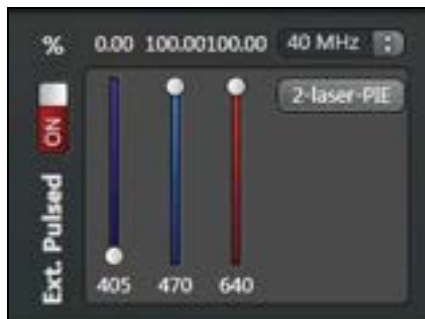

Figure 131: Beam Path Settings in LAS AF: Activating exactly two pulsed diode lasers

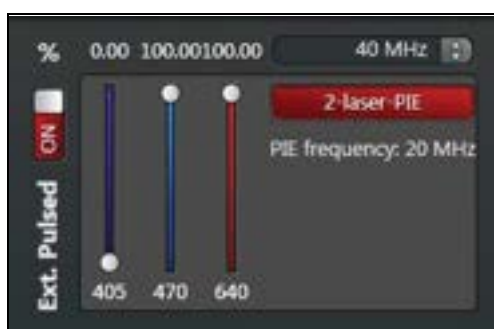

Figure 132: Dialog for selecting the laser pulse rate in the PIE mode; both lasers pulse at half the base frequency

Selecting **2-laser PIE** is not possible when activating a pulsed diode laser or when selecting three pulsed diode lasers, and the corresponding button is grayed out (**Figure 133**).

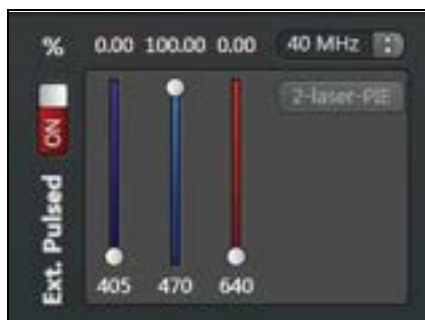

Figure 133: Activating a pulsed diode laser; the radio button for 2-laser PIE is grayed out

## 16.2.6 Changing Pulse Frequency for White Light Lasers

If a white light laser has a pulse picker, the repetition rate can be selected via a pull-down menu in **Beam Path Settings** in LAS AF (**Figure 134**). The laser is at 80 MHz when starting the system. In the pull-down menu, you can select the following frequencies: 80, 40, 20 and 10 MHz.



Figure 134: Selecting the white light laser pulse frequency in Beam Path Settings

If the repetition rate is changed, it can become necessary to adapt the resolution in SymPhoTime (see **Table 20**).



#### Do not select other frequencies on the laser

If you select **manual** in the pull-down menu, you can select additional frequencies on the laser yourself. This is, however, not recommended because the cable lengths are not calibrated for these frequencies.

## 16.2.7 Setting the Pinhole

On the **Acquisition** tab in LAS AF, set the pinhole diameter (**Pinhole**) to **1 Airy** for FLIM measurements with VIS and UV excitation and to the maximum value for MP excitation.

## 16.2.8 Optimizing FLIM Settings



#### Scan speeds 100 to 200 Hz recommended

Do not use scan speeds that are too high because these can lead to longer analysis times in SymPhoTime. Scan speeds at 100 to 200 Hz are recommended. Avoid the use of the resonant scanner for FLIM data acquisition as much as possible.

1. First, find the position of your specimen you want to use for FLIM measurement.
2. Click on the image acquisition button **Run FLIM Test** to start the scanning operation. You can view and optimize the fluorescence intensity in the **Count Rate Monitor** on the **Setup** tab (**Figure 135**).
3. Laser line and intensity can be modified during the test measurement until you attain the count rate desired.
4. When you start the test measurement, an online FLIM image is displayed in SymPhoTime.



#### The online FLIM image is not saved.

This image is not saved. To save your data, you have to work in the **Measurements** step.

5. If you want to view an online lifetime histogram, close the fast FLIM image in SymPhoTime. Click the symbol **Show Oscilloscope...** and select the **TCSPC histogram** tab.
6. To cancel specimen illumination, select the **Stop FLIM Test** button in the LAS AF software. This will also stop the online FLIM display in SymPhoTime.

The instrument parameters set for the FLIM measurements (laser lines and associated intensity, pinhole, scan mode, image size etc.) are kept as separate FLIM settings that are independent from the image acquisition setting defined in the **Setup Imaging** step. The FLIM settings defined in the **Setup FLIM** step are automatically transferred to the **Measurements** step.

### 16.2.9 Count Rate Monitor

The count rate of each channel is displayed in the **Setup** tab. For FLIM, the count rate should be between 10,000 and 1,000,000 cps (counts per second).



Figure 135: Count rate monitor in the FLIM Wizard

In addition, the count rate monitor shows the number of photons in the brightest pixel of the image. This value allows you to evaluate the image quality. The higher the number of fluorescence photons (counts) per pixel, the more accurately the lifetime can be determined. This value is updated regularly whenever a new scanning operation starts in the **Setup FLIM** step of the FLIM Wizard.

### 16.2.10 Loading and Saving FLIM-specific Instrument Parameter Settings

The instrument parameter setting (IPS) for FLIM can be saved and loaded in the same way as IPSs for normal intensity imaging.

Save the FLIM settings in the **Setup FLIM** step and settings for intensity image acquisition in the **Setup Imaging** step.

You can also load FLIM instrument parameter settings in the **Setup Imaging** step or outside the FLIM Wizard. In this case, these settings are treated as settings for normal image capture intensities.

## 16.3 Measurements Step – Time Series for FLIM Measurement at Multiple Points

After optimizing the FLIM measurement conditions, it is possible to have FLIM measurements run automatically. To do so, go to the **Measurements** step.

### 16.3.1 FLIM Network Connection

The LAS AF and SymPhoTime programs are synchronized via a network connection. Each FLIM measurement started in LAS AF in the **Measurements** step of the FLIM Wizard generates a new data file in SymPhoTime.

In addition to the synchronization, the network also enables the automatic transmission and implementation of scan parameters (format, scan speed, unidirectional or bidirectional scanning). In addition, other relevant information, such as the file name, instrument parameter setting (IPS) or comments entered by the user in LAS AF are transferred and stored in SymPhoTime.

During the FLIM measurement, an online FLIM image is displayed that is automatically saved along with the raw data in SymPhoTime. After the data acquisition, a more detailed data analysis can then be carried out offline.



#### Observe the SymPhoTime manual

For more detailed information about data analysis, refer to the SymPhoTime manual.

### 16.3.2 Definition of the FLIM Measurement File Names Transferred to SymPhoTime

1. Select the **Setup** tab.
2. Enter the name of the FLIM data file used in SymPhoTime in the **Base name** field in the pull-down menu **File/Series Definitions (Figure 136)**.

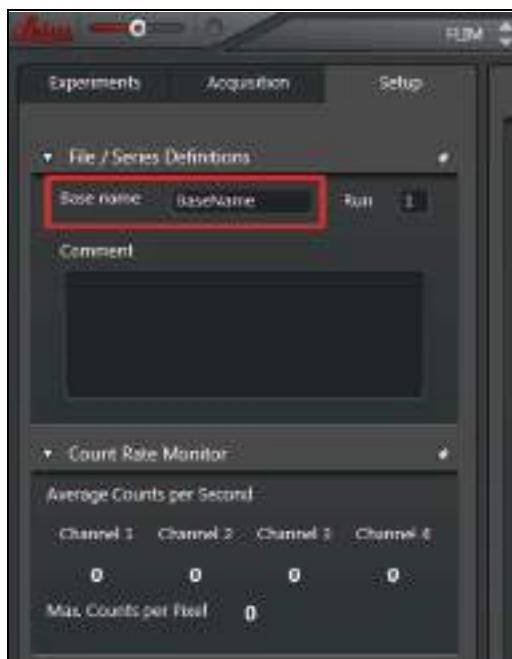

Figure 136: Defining FLIM image names

The naming structure is comprised of the following:

- Whenever a series of FLIM measurements is started, SymPhoTime generates a folder that houses all FLIM measurement files of this series. The folder name is comprised of the following:  
**"BaseName"\_"Run"**
  - **Base Name (BaseName):** The base folder and base file name used in SymPhoTime can be specified here. If the user does not enter a name, **BaseName** will be automatically used.
  - **Run:** This is a suffix that is added to the folder and file names transferred in SymPhoTime. In SymPhoTime, no two folders may have the same name. Therefore, the number given in the **Run** suffix is automatically increased by one whenever a measurement series is started. The '**Run**' suffix can be changed by the user.



#### Do not use the same name

Do not enter the same **BaseName\_Run** name twice. This will create an error message.

The file name uses the same **BaseName** and **Run** components as the folder. Additionally, LAS AF will automatically add one more suffix to the file name that indicates which image it is in the series. The file name will be created like this:

**"BaseName"\_"Run"\_"Image number"**

- The **Image number** suffix cannot be changed by the user.

The names used in LAS AF for the intensity images correspond to the folder names used in SymPhoTime. This makes it easier to allocate the data in LAS AF to that in SymPhoTime.





Figure 138: Defining a single FLIM image

7. In the **Defining FLIM Image acquisition time** dialog, you can define the duration of the acquisition of the individual image (Figure 138). To improve FLIM data statistics, multiple scanning operations are normally carried out with the specimen and the data is compiled into a final image. The following alternative options are possible:
  - **Duration of each image:** You can enter how long the data acquisition of an individual FLIM image is to last. The corresponding number of scanning operations are carried out on the specimen. The entered duration is corrected automatically so that a scanning operation is always stopped at the end of an image.
  - **Repetitions:** Enter the number of scans to be carried out.
  - **Acquire until max \_\_\_ photons/pixel:** With this option, the data acquisition is not stopped at a fixed point in time. Image acquisition ends if the brightest pixel contains more photons than specified here. With this option, images with comparable brightness and therefore comparable photon statistics can be acquired.
8. Start FLIM measurement by clicking on the image acquisition button **Run FLIM**.

In LAS AF, an image averaged across the entire measurement duration is shown.

### 16.3.4 Defining an xyz or xzy FLIM Stack

To acquire an FLIM stack, proceed as follows:

1. Select the specimen position.
2. In the **Setup FLIM** step on the **Acquisition** tab, select either the **Acquisition Mode xyz** or **xzy** as the scan mode (Figure 137). Optimize the instrument parameter setting for FLIM measurement.
3. Go to the **Measurements** step in the FLIM Wizard.
4. Define a file name (see Chapter 16.3.2) in the **Setup** tab.
5. Open the **Acquisition** tab.

- Define the first and last image of the stack and the number of planes via the stack dialog (**z-stack** or **y-stack**) (**Figure 139**).



**Figure 139:** FLIM stack definition xzy

- Define the duration of the individual FLIM images as described in **Chapter 16.3.3**. The option **Acquire until max \_\_\_ photons/pixel** is of particular interest for acquiring FLIM stacks. It enables corrections due to intensity changes caused by different sample penetration depths.
- Start the FLIM stack acquisition with the image acquisition button **Run FLIM**.

In LAS AF, you obtain a stack of averaged images and, in SymPhoTime, a series of FLIM images.

### 16.3.5 Defining an FLIM Time Series

To acquire an FLIM stack, proceed as follows:

- Select the specimen position.
- Select either **Acquisition Mode xyt** or **xzt** as the scan mode on the **Acquisition** tab. Optimize the instrument parameter setting for FLIM measurement.
- Define a file name in the **Setup** tab (**Chapter 16.3.2**).
- Open the **Acquisition** tab.

5. Define the duration of the individual FLIM images as described in **Chapter 16.3.3**. For recording a FLIM time series, use either **Duration of each image** or **Repetitions**, because the last option, (**Acquire until max \_\_\_\_ photons/pixel**), does not allow a fixed period of time to be specified.
6. You can define a time series using the time series dialog (**Figure 140**). The following inputs are possible:
  - **Time Interval:** Defines the time between the beginning of one FLIM image and the next image. This duration cannot be shorter than the duration entered for a single FLIM image. To specify the smallest possible duration, select **Minimize**.
  - **Duration:** Here, enter how long the entire time series is to last. The corresponding number of FLIM images is acquired. The duration entered is automatically corrected so that all FLIM images can be completed.
  - **Frames:** You can specify the number of FLIM images to be acquired. The maximum specified number is 1000.



**Figure 140: Defining an FLIM time series**

7. Enter the desired value in the time series dialog.
8. Start the FLIM time series acquisition with the image acquisition button **Run FLIM**.

In LAS AF, you obtain a time series of averaged images and, in SymPhoTime, a series of FLIM images.

### 16.3.6 Defining a Time Series of xyz or xzy FLIM Stacks

Proceed as follows to take a time series of FLIM stacks:

1. Select the specimen position.
2. Select either **Acquisition Mode xzyt** or **xyzt** as the scan mode on the **Acquisition** tab. Optimize the instrument parameter setting for FLIM measurement.

3. Define a file name in the **Setup** tab (**Chapter 16.3.2**).
4. Open the **Acquisition** tab. Via the stack dialog, you define the first and last image of the stack and the number of planes (**Figure 139**).
5. Define the duration of the individual FLIM images as described in **Chapter 16.3.3**. Use either **Duration of each image** or **Repetitions**, because the last option, **Acquire until max \_\_\_ photons/pixel**, does not allow a fixed period of time to be specified.
6. You can define a time series using the time series dialog (**Figure 141**). The following inputs are possible:
  - **Time Interval:** defines the duration between the beginning of an FLIM stack and the next stack. This time span cannot be shorter than the timespan required for an individual FLIM stack. To specify the smallest possible duration, select **Minimize**.
  - **Duration:** Here, enter how long the entire time series is to last. The corresponding number of FLIM stacks is acquired. The entered duration is automatically corrected so that the last FLIM stack can be completed.
  - **Stacks:** Here, you can specify the number of FLIM stacks to be acquired. The maximum specified number of FLIM images is 1000.



**Figure 141:** Defining a time series of xyzt FLIM stacks

7. Enter the desired value in the time series dialog.
8. Start the FLIM experiment recording with the **Run FLIM** button.

In LAS AF, you obtain a time series of averaged images of stacks and, in SymPhoTime, a series of FLIM images.

### 16.3.7 Defining an $xy_\lambda$ or $xz_\lambda$ FLIM Stack

These modes are only available for systems that are equipped with internal SP FLIM detectors. During the generation of  $\lambda$  stacks, the spectral sliders of the SP FLIM detectors are shifted incrementally. To acquire an FLIM stack, proceed as follows:

1. Select the specimen position.
2. In the **Setup FLIM** step on the **Setup** tab, select the **Internal (SP FLIM)** option (**Chapter 16.2.1**).
3. In the **Measurements** step on the **Acquisition** tab, select either the **Acquisition Mode**  $xy_\lambda$  or  $xz_\lambda$  as the scan mode. Optimize the instrument parameter setting for FLIM measurement.
4. Define a file name in the **Setup** tab (**Chapter 16.3.2**).
5. Open the **Acquisition** tab. If the correct SP FLIM detector is not yet selected, select it in the **PMT-Selection** line. In **Beam Path Settings**, the detector selection cannot be changed.
6. Define the stack in the  $\lambda$  stack dialog as follows (**Figure 142**):
  - **Detection Begin** and **Detection End**: Wavelength of the first and last FLIM image
  - **Detection Band Width**: Width of the spectral range of an individual FLIM image
  - **No. of Detection Steps**: Number of FLIM images that are acquired from different spectral ranges
  - $\lambda$  -**Detection Stepsize**: Step size of the spectral slider from one image to the next



Figure 142: Defining  $xy\lambda$  FLIM stacks

7. Define the duration of the individual FLIM images as described in **Chapter 16.3.3**. If all images are to have a comparable brightness, use the **Acquire until max \_\_\_ photons/pixel** option. It enables corrections of intensity changes which are caused by the emissions spectrum and by bleaching artefacts. If spectral intensity information is required, use **Duration of each image** or **Repetitions**.
8. Start the FLIM stack acquisition with the image acquisition button **Run FLIM**.

In LAS AF, you obtain a  $\lambda$  stack of averaged images and, in SymPhoTime, a series of FLIM images.

### 16.3.8 Defining a Time Series of $xy\lambda$ or $xz\lambda$ FLIM Stacks

These modes are only available for systems that are also equipped with internal SP FLIM detectors.

1. Select the specimen position.
2. In the **Setup FLIM** step on the **Setup** tab, select the **Internal (SP FLIM)** option (**Chapter 16.2.1**).
3. In the **Measurements** step on the **Acquisition** tab, select either the **Acquisition Mode**  $xy\lambda t$  or  $xz\lambda t$  as the scan mode. Optimize the instrument parameter setting for FLIM measurement.
4. Define a file name in the **Setup** tab (**Chapter 16.3.2**).
5. Open the **Acquisition** tab. If the correct SP FLIM detector is not yet selected, select it in the **PMT-Selection** line. In **Beam Path Settings**, the detector selection cannot be changed.

6. Via the  $\lambda$  stack dialog, define the stack as described in **Chapter 16.3.7 (Figure 142)**.
7. Define the duration of the individual FLIM images as described in **Chapter 16.3.3**. Use either **Duration of each image** or **Repetitions**, because the last option, **Acquire until max \_\_\_ photons/pixel**, does not enable the specification of a fixed period of time.
8. You can define a time series using the time series dialog (**Figure 143**). The following inputs are possible:
  - **Time Interval:** Defines the duration between the beginning of an  $\lambda$  FLIM stack and the next stack. This time span cannot be shorter than the timespan required for an individual  $\lambda$  FLIM stack. To specify the smallest possible duration, select **Minimize**.
  - **Duration:** Here, enter how long the entire time series is to last. The corresponding number  $\lambda$  of FLIM stacks is acquired. The entered duration is automatically corrected so that the last  $\lambda$  FLIM stack can be completed.
  - **Stacks:** Here, you can specify the number of  $\lambda$  FLIM stacks to be acquired. The maximum specified number of FLIM images is 1000.

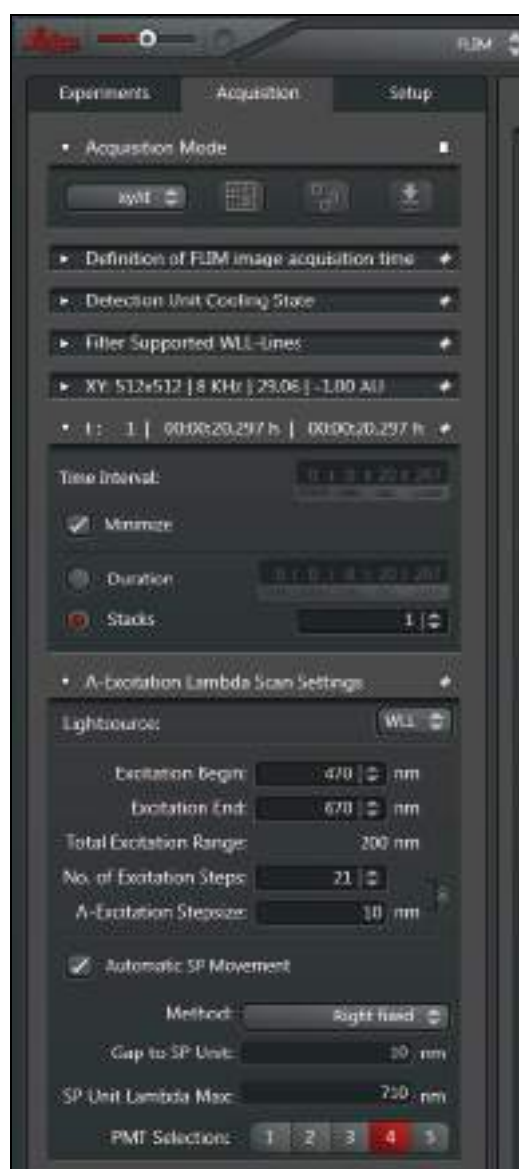

**Figure 143:** Defining a time series of  $\lambda$  FLIM stacks

- Start the FLIM  $\lambda$  stack acquisition with the image acquisition button **Run FLIM**.

In LAS AF, you obtain a  $\lambda$  stack of averaged images and, in SymPhoTime, a series of FLIM images.

### 16.3.9 Defining an $xy\Delta$ or $xz\Delta$ FLIM Stack

These modes are only available for systems that are equipped with variable-frequency lasers (white light lasers, MP lasers). In the following, the acquisition of  $xy\Delta$  or  $xz\Delta$  FLIM stacks with the white light laser is described:

- Select the specimen position.
- In **Beam Path Settings** in the white light laser dialog, select the mode **Constant Power** (Figure 144).



Figure 144: Selecting the Constant Power mode

- In the **Setup FLIM** step on the **Setup** tab, select the option **Internal (SP FLIM)** or **External** (Chapter 16.2.1).
- In the **Measurements** step on the **Acquisition** tab, select either the **Acquisition Mode**  $xy\Delta$  or  $xz\Delta$  as the scan mode.
- Check that the correct detector for the FLIM measurement is activated in the  $\Delta$  stack dialog.
- Optimize the instrument parameter setting for FLIM measurement. While doing so, test different excitation wavelengths.
- Define a file name in the **Setup** tab (Chapter 16.3.2).
- Open the **Acquisition** tab. If you want to use a spectral internal FLIM detector, select it in the **PMT Selection field** (Figure 146). If you remove the check next to **Automatic SP Movement**, you can manually select the external detector manually with white light or MP laser excitation in **Beam Path Settings**.



Figure 145: Select the detector in Beam Path Settings

9. Define the stack in the  $\Delta$  stack dialog as follows (Figure 146):

- **Excitation Begin** and **Excitation End**: Excitation wavelength of the first and last FLIM image
- **No. of Excitation Steps**: Number of FLIM images that are taken from the different excitation wavelengths
- $\Delta$  **Excitation Stepsize**: Step size of the excitation wavelength from one image to the next



Figure 146: Defining  $xy\Delta$  FLIM stacks

10. Define the duration of the individual FLIM images as described in **Chapter 16.3.3**. If all images are to have a comparable brightness, use the **Acquire until max \_\_\_ photons/pixel** option. It enables corrections of intensity changes which are caused by the excitation spectrum and by bleaching artefacts. If intensity information is required, use **Duration of each image** or **Repetitions**.
11. Start the FLIM stack acquisition with the image acquisition button **Run FLIM**.

In LAS AF, you obtain a  $\Delta$  stack of time-averaged images and, in SymPhoTime, a series of FLIM images.

### 16.3.10 Control of FLIM Measurements

The measurement series is started by clicking on the **Start FLIM** image acquisition button. It stops automatically after all measurements are taken. A user-defined stop is possible by clicking the **Stop FLIM** image acquisition button.

In the count rate monitor (**Figure 147**), the current count rate (in cps - counts per second) is displayed during the individual measurements. In the line **Max. counts per pixel**, the total number of photons accumulated so far in the brightest pixel of the image is shown. This gives an initial indication as to whether the photon statistics in the image are sufficient.

After start of the FLIM series, fast FLIM images are displayed in SymPhoTime online and saved together with the raw data.

Both the count rate and fast FLIM images give a first impression about the quality of the measurements.

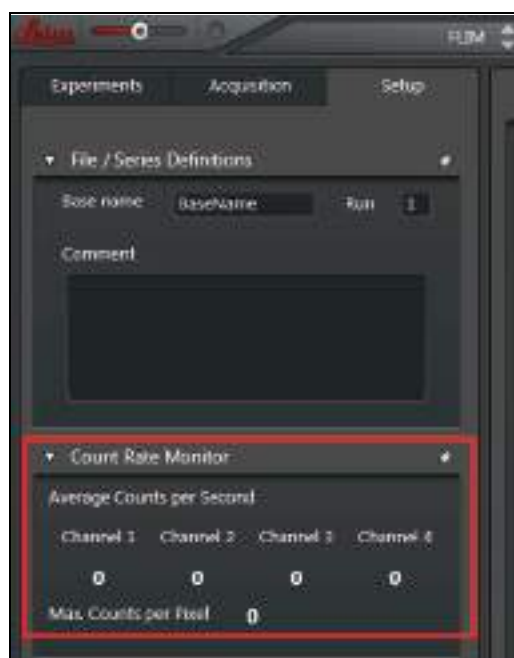

Figure 147: Count rate monitor in the Measurements step of the FLIM Wizard

## 17 Summarized Manual for FLIM Experiments

### 17.1 Prerequisites

The following description assumes that the following prerequisites are met:

- SymPhoTime has been started and a workspace has been loaded.
- LAS AF was started.
- All components (lasers, detectors, software) of the PicoQuant SMD upgrade are switched on. Detailed information on starting the components can be found in **Chapter 13.4**.
- The right objective is chosen with high numerical aperture and - if present - the correction ring is adjusted to the specimen used (**Chapter 18.1.1** and **Chapter 18.1.4**).
- Your specimen is already placed onto the microscope and brought into focus.
- The selected excitation lasers are switched on and activated (**Chapter 15**).
- The correct emission filter(s) was placed in front of the detectors. For external FLIM detectors, the correct SMD filter cube has to be set in the X1 port adapter (**Chapter 23**); for internal SP FLIM detection, the barrier filter in the fluorifier disc is used (**Chapter 16.2.3**). With HyD RLD, the correct barrier filter and a suitable filter cube must be used in the detector unit.
- For beam splitter systems: The correct beam splitter for your wavelength has been selected in LAS AF. If pulsed diode lasers are used, the beam splitter is to be in the **Substrate** position.
- With AOB systems: The acousto-optical beam splitter is in fluorescence mode.

### 17.2 Selecting Position for the FLIM Measurement

1. Start the Wizard in LAS AF by selecting the **FLIM** operating mode.
2. Scan an image (for this, use the **Setup Imaging** step in the FLIM Wizard). To be able to get an initial overview, you can use continuous wave lasers and internal detectors.
3. Select the correct sample region at which the FLIM measurement is to be carried out.

### 17.3 Changing from Continuous to Pulsed Excitation

1. Make sure that the PicoQuant laser driver is set to external trigger.
2. In the FLIM Wizard in LAS AF, go to the **Setup FLIM** step.
3. Select a suitable laser wavelength for pulsed excitation (**Chapter 16.2.2**).
4. Check whether the selectable beam splitter for **MFP** is in the correct position (**Chapter 16.2.2**).
5. Select the laser pulse frequency (repetition rate) in LAS AF (**Chapter 16.2.4**). In general, 40 MHz is the best frequency to start with. Lower the frequency to 20 MHz only if you determine that your lifetime decay curve does not fit in the TCSPC histogram. This

applies for pulsed diode lasers and white light lasers with a pulse picker only. The repetition rate of multiphoton lasers cannot be adapted (other than with a pulse picker). For details, see **Chapter 17.9**.

## 17.4 Changing from Internal Detection on the SP8 to External TCSPC Detectors

1. In the FLIM Wizard in LAS AF, go to step **Setup FLIM**.
2. If you want to carry out your time-resolved experiments with the external PicoQuant detectors, configure the detection beam path in the scan head to direct the fluorescence to the X1 output port (that means the **X1 Port** at position ---)(Chapter **Chapter 16.2.1** and **Chapter 16.2.1.2**). This is done automatically when you select the **External FLIM** detector in the "Setup" tab (**Chapter 16.2.1, Figure 119**).
3. If you have two single detectors, set the appropriate SMD filter cube inside the X1 port adapter to split the appropriate spectral range of the emission light to the two detectors.
4. Make sure that suitable fluorescence detection filters (band pass / long pass) are present in the corresponding filter holders of the PicoQuant detector unit(s). If the detection filters and beam splitters are already placed inside the X1 port adapter, you can leave the filter holders in front of the detectors empty. However, a filter holder must be located in front of the detector in order to open its shutter.

### Pay attention to the APD detection unit manual



When using a two-channel APD detector unit from PicoQuant, ensure that the beam splitter in the beam splitter turret is set so that it distributes the emission light to the detectors correctly. Detailed information can be found in the detection unit manual.

## 17.5 Using Internal SP FLIM Detection

1. In the FLIM Wizard in LAS AF, go to step **Setup FLIM**.
2. Select the FLIM detector **Internal (SP FLIM)** on the **Setup** tab (**Chapter 16.2.1, Figure 119**). This automatically moves the X1 port to the position **Mirror** that reflects the emission light to the SP detection module within the SP8 scan head.
3. Select a suitable spectral detection range by moving the mirror sliders of the detectors in the **Beam Path Settings** (Chapter **Chapter 16.2.1.1**).
4. Check whether the fluorifier disc is in the correct position (**Chapter 16.2.3**).

## 17.6 Using FLIM Detectors at the NDD Position (HyD RLD)

1. In the FLIM Wizard in LAS AF, go to step **Setup FLIM**.
2. Select the FLIM detector **Non descanned (MP FLIM)** on the **Setup** tab (**Chapter 16.2.1, Figure 119**). By doing so, a beam splitter in the stand which decouples the fluorescent light to the HyD RLD automatically swings into the beam path.
3. Make sure that the correct barrier filter and the suitable filter cube are placed in the

detector module.

4. Check whether the fluorifier disc is in the correct position (**Chapter 16.2.3**).

## 17.7 Setting Suitable Scan Parameters

Determine the correct scan template in LAS AF in the FLIM Wizard's **Setup FLIM** step. The following settings should be made on the **Acquisition** tab:

- **monodirectional scan** (bidirectional scan is only supported for zoom >8)
- maximum **512 x 512** pixels  
Using a low number of pixels (e.g. **256 x 256**) is recommended. With a low number of pixels, more photons can be collected in the individual pixels. In this way, a better allocation of the lifetime data is possible.  
Even the summary of pixels (binning) is possible later in the analysis range in order to calculate and analyze an image with low number of pixels. This will result in no loss of the acquired fluorescence.
- The averaging mode (as **Average** or **Accumulation**) of LAS AF is not accessible within the SMD-FLIM Wizard, because it is not to be used for scanning operations.
- moderate scan speed (100 to 200 Hz)  
With increasing numbers of acquired individual images, the calculation time increases for all steps of the FLIM analysis. Avoid the use of the resonant scanner for FLIM data acquisition.

## 17.8 Optimizing the Photon Count Rate

1. In the FLIM Wizard in LAS AF, go to the **Setup FLIM** step.
2. Start the scanning operation in the test mode by clicking on the image acquisition button **Run FLIM Test**. Normally, the SymPhoTime software will start the data acquisition and display automatically. You can also start the FLIM data acquisition by selecting the **Acquire LSM Measurements** button in SymPhoTime.



### FLIM data is not saved with Run FLIM Test

The **Run FLIM Test** option is only intended for the optimization of the instrument parameter settings. The corresponding FLIM data is not saved.

The **Measurement Preview** dialog in SymPhoTime software opens on the **Image** tab (**Figure 148, right**).

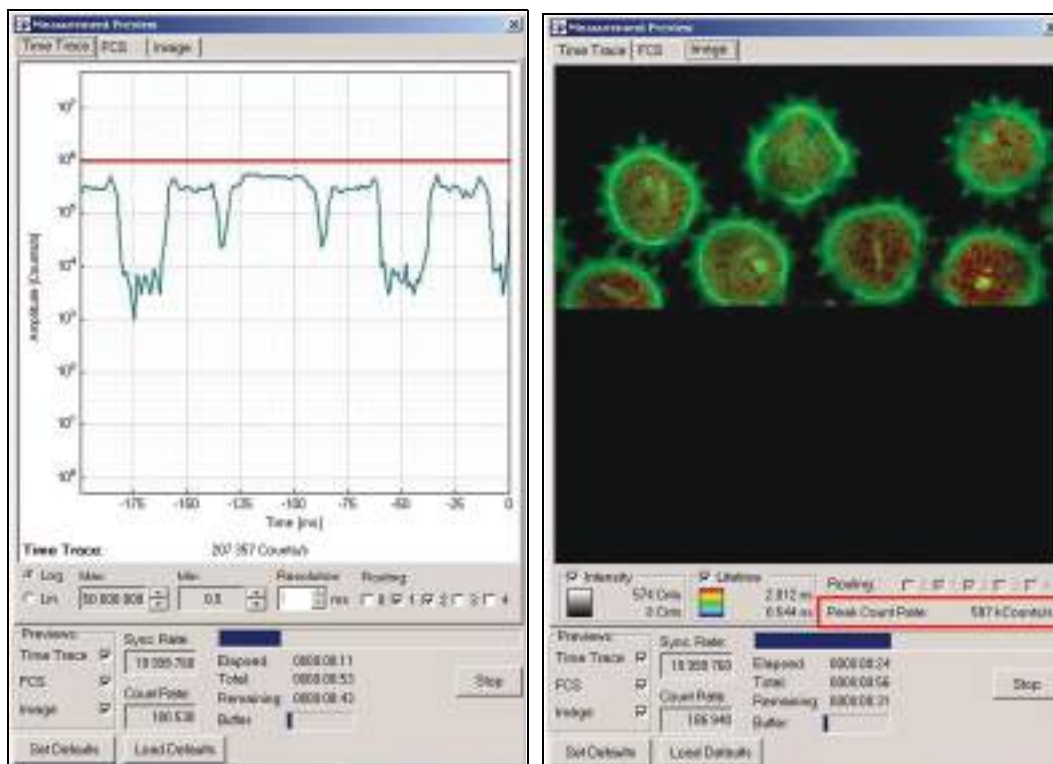

**Figure 148:** Online monitoring of the photon count rate in the SymPhoTime preview window. Left: Display of the count rate over time. Right: FLIM image preview specifying the maximum count rate (red rectangle).

3. Make sure that the maximum **Peak Count Rate** is below the values given in the table below **Table 21**.

Laser pulse frequency (repetition rate)	Upper count rate limit for different detectors, in [kcounts/s]	
	PMA photomultiplier or MPD APD (MPD)	PE AQR APD PE APD (AQR)
40 MHz	1000	700
20 MHz	1000	700
10 MHz	500	500
5.0 MHz	250	250
2.5 MHz	125	125

**Table 21:** Upper count rate limit for FLIM detection with different detectors

The reason for limiting the detection count rate lies in the **Pile-up** effect that causes an apparently shorter lifetime at high detection count rates.

For example, using a laser repetition frequency of 40 MHz and a detection count rate of 1 MHz leads to an error of below 1% for the calculated lifetime. At a 3 MHz count rate, the obtained lifetime will be 2% too low. The error induced by the pile-up effect is proportional to the ratio between the detection count rate and the laser repetition frequency. The maximum measurement count rate is calculated from the maximum of the **time trace** displayed on the tab of the same name (see **Figure 148, left**). The binning (**resolution**) should be set to 1 ms. This allows you to see the changes of the count rate over time.

4. Make the settings in the **Measurement Preview** window (such as the selection of the displayed channels, the resolution of the time trace etc.) by selecting the **Show Measurement Preview...** button in SymPhoTime while no measurement is running. Defaults can be saved using the **Set Defaults** button.
5. Adjust the photon count rate by changing the intensity of the diode laser at the laser coupling unit (LCU) (**Chapter 9.6**) or, if you do not have an LCU, but rather a direct fiber coupled laser, in a similar way at the laser scaffold with the intensity regulation knob. Information on attenuation by modifying the laser current can be found in the manual on the laser driver (PDL or SEPIA). Keep in mind that changing the laser intensity via the laser current does alter the pulse shape of the laser.
6. Control the white light or MP laser intensity directly in LAS AF.
7. For adjustment use the peak count rate in the preview window in SymPhoTime, since the average count rate does not give you information about the count rate in the brightest parts of the image.  
Regions of the image recorded with photon count rates above the limit (**Table 21**) can lead to inaccurate fluorescence lifetimes being calculated.
8. To attain the shortest possible FLIM data acquisition time, we recommend increasing the photon count rate wherever possible to the TCSPC limit listed in **Table 21**. Of course, for weak fluorescent specimens, this upper limit cannot be attained, even at maximum laser power.

Using the **Image** tab in the **Measurement Preview** window in SymPhoTime, you can see a preview of the FLIM image. The lifetime displayed in the image by the color code is calculated by the mean arrival time of the fluorescence photons after the last laser pulse. The image is updated almost once each second if the scanning speed exceeds one frame per second. It will be slower at lower scanning frequencies.

9. Make sure that even in group measurements, these high count rates are not reached, as otherwise the group measurement will stop.
10. In order to reach even higher detection count rates for FLIM, the fast FLIM preview can be switched off using the check boxes under **Previews** in the FLIM preview window (**Figure 148**).

**Upper limit for the count rate**

Unnecessarily low photon count rates lead to an extension the data acquisition, because a certain number of photons is required for the FLIM analysis. On the other hand, too high of photon count rates can lead to artifacts and falsify the FLIM analysis due to the pile-up effect. The upper limit for the count rate is given by:

- TCSPC principle: To prevent pile-up artifacts (pile-up effect: overestimation of early photons), the identified photon count rate in general should lie at around 5% under the laser repetition rate. When using a laser repetition rate of 20 MHz, this results in a photon count rate of 1 MHz (1,000 counts/ms). This setting leads to a maximum underestimation of the fluorescence lifetime of 1% due to the pile-up effect.
- TCSPC detector: Some detectors lead to occurrence of artifacts if they are operated with a high count rate. The APD from type AQR by Perkin Elmer shows a substantial IRF widening at a photon count rate above 1 MHz and a count rate-dependent IRF movement.
- TCSPC electronics: The acquired photon data are transmitted continuously via a FIFO buffer from the TCSPC unit (PicoHarp) to the workstation. If average photon count rates above approx. 3 MHz are reached (depending on the workstation power), the data acquisition stops and an error message is displayed:



## 17.9 Selecting the Correct Laser Repetition Rate

For pulsed diode lasers from PicoQuant and for the white light laser with pulse picker, the laser repetition rate can be determined in LAS AF (**Chapter 16.2.4**). In general, the repetition rate should be as high as possible to achieve the highest possible photon count rate. However, the time window after a laser pulse should still be large enough to allow complete fading of the fluorescence of the excited dye molecules before the next laser pulse.

For example, the duration between two laser pulses at a repetition rate of 80 MHz is 12.5 ns. If a fluorophore with a lifetime of 6 ns is measured, due to the statistical process, more than 12% of the photons are emitted after 12.5 ns. In this case, the repetition rate must be decreased (**Figure 149**). At a laser repetition rate of 80 MHz, the fluorescence does not fade completely before the end of the time window. Due to a "wrapping effect", the end of the fading can be observed before the actual laser pulse (**Figure 149 A**). At 40 MHz the time window is optimally adapted (**Figure 149 B**), while at 20 MHz the fluorescence has already decayed at less than half of the detection window (**Figure 149 C**). Therefore, 40 MHz would be the optimal repetition rate in this case.



### Repetition rate with pulsed diode lasers

In the supplied configuration, 40 MHz is the maximum repetition rate for the pulsed diode lasers. 80 MHz is available only if the trigger on the laser driver (PDL, SEPIA) is set to **internal**. This bypasses the laser settings in LAS AF. In addition, all functions related to beam blanking (such as ROI scanning or line-by-line sequential scanning) are deactivated. A change of synchronization cable length will be necessary as well.

1. Run a test measurement by selecting **Run FLIM Test** in LAS AF.
2. The **Measurement Preview** window opens in SymPhoTime (**Figure 148** right). Close this window by selecting the **Stop** button.
3. You can now test the fading behavior of your specimen using the oscilloscope window in the SymPhoTime software. Select **Show Oscilloscope...**
4. Select the TCSPC tab **Histogram**, select **Start** and monitor the fading of the fluorescence as shown in **Figure 149**.

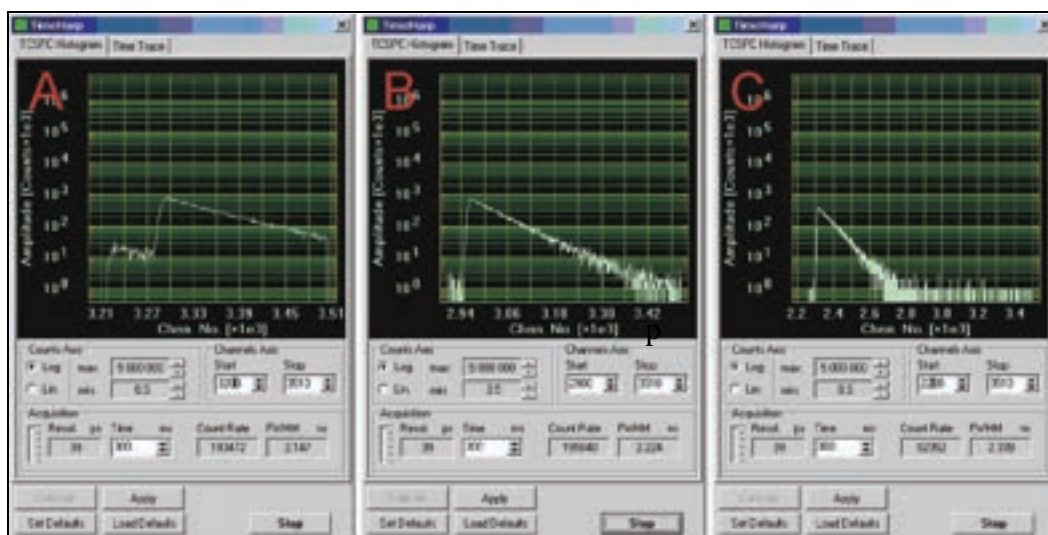

**Figure 149:** Fading of the fluorescence at too high of a laser repetition rate (A, 80 MHz), optimum laser repetition rate (B, 40 MHz) and unnecessarily low laser repetition rate (C, 20 MHz).

5. In this window, you can select the time resolution per bin of the TCSPC histogram with the slider under **Acquisition**.
6. Please confirm your selection by selecting **Apply**.

## 17.10 Starting FLIM Data Acquisition



### Prevent light incidence during MP FLIM measurement

During an MP FLIM measurement, the room light should be switched off and the shutter of the fluorescence lamp should be closed. Furthermore, the iris diaphragm on the condenser should be completely closed.

1. Go to the **Measurements** step in the FLIM Wizard in LAS AF.
2. In the **Setup** tab, type in a file name that will be used in SPT (**Chapter 16.3.2**).
3. Specify the measurement time of the FLIM image (**Chapter 16.3.3**).
4. If you wish, define a volume or lambda stack or a time series (**Chapter 16.3.4** to **Chapter 16.3.8**).
5. Start the scan procedure in LAS AF by selecting the **Run FLIM** image acquisition button. Normally, the SymPhoTime software will start the data acquisition automatically. However, for a single FLIM measurement, you can also start the FLIM data acquisition manually by selecting the **Acquire LSM Measurements** button.

During the SP8 data acquisition, the preview window is displayed in the SymPhoTime software (**Figure 148**), in which you can see the FLIM preview image. When scanning the specimen several times, all frames are accumulated over time. This display allows you to evaluate the quality of the FLIM data acquired. In doing so, note that the FLIM preview image is accumulated for display only. Based on the stored raw data, separate individual images can still be analyzed.

6. The SP8 scanning operation stops either after having scanned the chosen number of frames or can be stopped manually by selecting **Stop FLIM** to interrupt the data acquisition.

The recorded FLIM images will be stored in the SymPhoTime software and are accessible for further data analysis from the workspace.

## 17.11 Resulting Raw Data File and Documentation

The resulting raw data file and documentation is shown in the SymPhoTime software.

The measurement result is an FLIM image with a \*.PT3 raw data file, which contains the greatest available data volume for each photon detected (temporal and spatial information related to the detection channel).

Each raw data file is saved with an annotation file. It is characterized in the working area overview by a symbol in the shape of a red dot (**Figure 150**). The raw data file contains all measurement parameters transferred to SymPhoTime software and contains a preview image (bitmap) which provides a first impression of the image scanned.

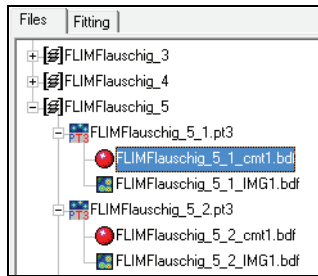
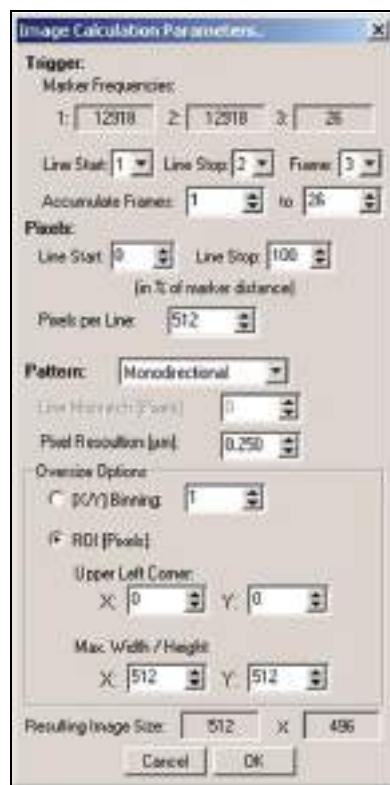

**Figure 150:** Annotation file in the workspace overview in SymPhoTime

1. You can enter individual information (such as measurement type, specimen etc.) manually.
2. For access to certain acquired individual images of an individual FLIM measurement, the image can be recalculated using the **options...** button.

A window with image specifications pops up (**Figure 151**).

3. Enter the individual images to be selected for the analysis in the **Accumulate Frames** field (from individual image No.\_to individual image No.\_).



**Figure 151:** Changing the selection of the individual image numbers for the analysis in the SymPhoTime Software

## 17.12 Measuring the Instrument Response Function (IRF)

For accurate measurements of lifetimes near to the timing resolution, the instrument response function (IRF) should be taken into account. The width of the IRF displays the timing resolution of the instrument.

For determination and use of the instrument response function (IRF) in MP systems with HyD RLD, it is advisable to place a black, non-reflective piece of paper between the specimen and the condenser.

### 17.12.1 Preparing IRF Measurements

There are different ways to obtain an IRF.

#### 17.12.1.1 Estimating the IRF

The IRF function normally has to be measured separately. However, SymPhoTime can also measure the IRF function starting from the ascending edge of the TCSPC decay curve.



#### Pay attention to the SymPhoTime online help

Further information can be found in the SymPhoTime online help.

#### 17.12.1.2 With Reflection Mode

Only use the reflection mode if no suitable fluorescence specimen is available. It might create additional signals not relevant in real fluorescence experiments. Aside from that, the IRF is dependent on the wavelength APD.

1. Position a backscattering specimen (such as a cover slip or a mirror) in the laser focus on the specimen stage of the microscope. Alternatively, you can use Ludox or milk in a measurement chamber.
2. Remove all barrier filters from the emission path so that the laser line used reaches the detector.
3. For external FLIM detection, remove the band pass filters from the SMD filter cube.
4. Bring the fluorifier disc into the **Substrate** position.
5. Place an OD3 attenuating filter in the filter holder in front of the detector or apply very low laser intensity. The correct filter holder position can be taken from the detector manual.

### 17.12.1.3 With Fluorescence Mode

This is the preferred mode for MP and pulsed VIS or UV excitation, because the conditions of the IRF measurement match the measurement conditions of the real experiment.

1. Use a dye with a very short lifetime (a few picoseconds) in a measurement chamber. A dye can be used for IRF measurements if the fluorescence decay time is much shorter than the IRF width. An example for such a dye is picric acid.

**WARNING Risk of severe injuries from picric acid**



Picric acid is poisonous and causes a danger of explosion. Observe your country-specific regulations, which are indicated on the safety data sheet.

2. For external FLIM detection select an appropriate SMD filter cube which will be used for your final measurement. For SP FLIM detection, make sure the fluorifier disc is in the correct position (**Chapter 16.2.3, Table 19**).
3. An additional attenuation filter in the filter holder in front of the external detector may not be required.

Dyes with a very short lifetime can be made with the following recipe: A saturated aqueous dye solution is created from a spectrally suitable dye with good water solubility. Potassium iodide is added to this solution until the dye solution is saturated with it. The potassium iodide usually quenches the fluorescence so strongly that the fluorescence lifetime of the solution sinks to below 100 ps FWHM and thus can also be used for IRF measurements. The advantage of this method is that the IRF can be measured at the same emission wavelengths as it is in the final measurement. This method can also be used for multi-photon excitation (refer also to Szabelski M. et al., Collisional quenching of Erythrosine B as a potential reference dye for impulse response function evaluation, Applied Spectroscopy, 63, 2009).

### 17.12.1.4 With SHG (Second Harmonic Generation – Possible for MP Lasers Only)

1. Use a SHG-capable specimen without lifetime or with very short lifetime (a few picoseconds) in a measurement chamber. A typical example of a SHG specimen is muscle tissue, collagen or urea powder mounted on a cover slip.
2. Emission happens at roughly half the excitation wavelength (for instance excitation at 900 nm, emission at 450 nm). For external FLIM detection, select an appropriate SMD filter cube that allows SHG emission to pass through.
3. The fluorifier disc has to be in the in position **SP700** or **SP680**.
4. For SP FLIM detectors, move the spectral slider such that the emitted light hits the SP FLIM detector.
5. For external detection, remove all additional filters from the filter holder in front of the detector.

## 17.12.2 Running IRF Measurement

Carry out the following steps to measure the IRF:

1. In the FLIM Wizard in LAS AF, go to step **Setup FLIM**.
2. Start the scanning operation in test mode by selecting the image acquisition button **Run FLIM Test**. Normally, the SymPhoTime software will start the data acquisition automatically. However, you can also start the FLIM data acquisition by selecting the **Acquire LSM Measurements** button.



### Data is not saved.

Data from a scan in test mode is not saved.

3. Enable the **Time Trace** tab in the measurement preview window.
4. Adjust the focus of the microscope in order to maximize the displayed count rate.
5. Set the count rate to approximately 50,000 count/s.
6. The laser output power must not be changed on the laser driver itself, but only on the laser coupling module (LCU) or on the scaffold on the laser head.

Changing the laser driver settings typically changes the shape and temporal position of the laser pulse. You can use the driver settings to optimize the pulse shape of the laser for shortest IRF width.

7. You can now test the fading behavior of your specimen in the oscilloscope window in the SymPhoTime software. For this purpose, quit the preview and select **Show Oscilloscope....**
8. Select the **TCSPC Histogram** tab, select **Start** and monitor the fading of the fluorescence as shown in **Figure 152**. In the oscilloscope window, the time width per channel can also be set.

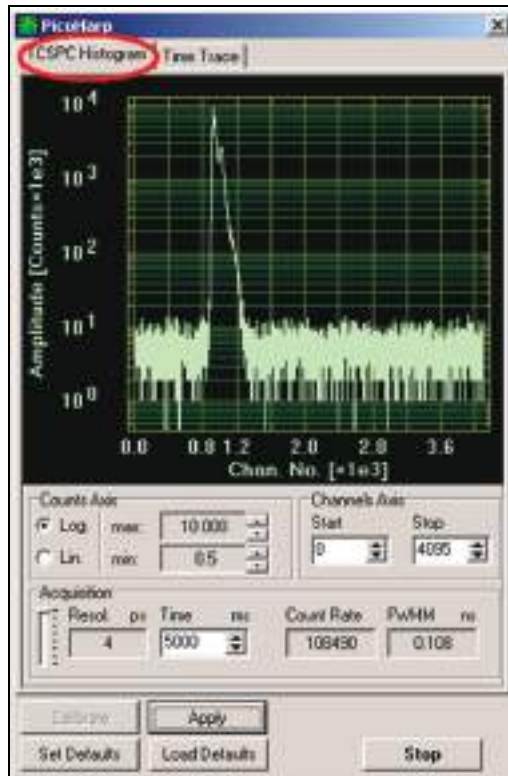

Figure 152: IRF oscilloscope window, acquired with PH300, APD of type MPD and PQ laser source

9. The time width per channel can be set with the **Resol.** slider. After a change, select the **Apply** button.
10. Quit the oscilloscope display in SymPhoTime by selecting the **Stop** button.  
Steps 7 and 10 are used only to check the IRF shape; they do not have to be carried out routinely.
11. End the scanning operation in test mode in LAS AF by selecting **Stop FLIM Test** again.
12. Go to the **Measurements** step in the FLIM Wizard.
13. Start the scan procedure in LAS AF by selecting the **Run FLIM** image acquisition button. Normally, the SymPhoTime software will start the data acquisition automatically. You can also start the FLIM data acquisition by selecting the **Acquire LSM Measurements** button. In both cases, data are saved.
14. Quit the image acquisition in LAS AF by clicking on **Stop FLIM**.
15. Replace the IRF specimen with your specimen and reinsert the correct filter for your specimen. Open the TCSPC histogram of the previously acquired image. It contains the IRF.

## 17.13 Remarks

### 17.13.1 Ad-hoc-Inspection of a Specimen

For the ad hoc inspection of your specimens, you can also use the pulsed lasers in conjunction with the internal SP8 PMT detectors. Typical pulsed lasers have a lower power than continuous wave lasers (cw lasers). Therefore, images of weak fluorescing specimens should be acquired at a slower scan speed.

### 17.13.2 Bidirectional Scanning

Bidirectional scanning is only possible for a zoom  $>6$ . The SymPhoTime software can only partly compensate for mismatches caused by bidirectional scanning during image analysis. The **Line Mismatch** adjustments are set in the **options...** menu, which is opened with the **options...** button. If the hysteresis effects cannot be compensated, it is preferable to perform monodirectional scanning operations.

### 17.13.3 Setting the Laser Intensity of the Diode Lasers

The laser intensity of the diode lasers can be adjusted in two different ways:

- The light intensity can be reduced on the fiber coupling module (using the filter wheel and the scaffold - or only the scaffold for direct fiber-coupled laser heads).
- The intensity can be controlled via the PDL800 or SEPIA controller. If the intensity is changed at the PDL800 or the SEPIA, this changes the pulse shape and thus the instrument response function (IRF). Acquire the IRF and the fading of the fluorescence using the same laser settings on the PDL800 or SEPIA if you want to carry out another FLIM deconvolution. The pulse width of the laser and thus the time response of the instrument (width of the IRF) can be optimized by selecting the laser power setting at the laser driver.

### 17.13.4 Sensitivity of the Fluorescence Detection

The sensitivity of the fluorescence detection of the optical system can also be increased by opening the pinhole of the TCS SP8 in LAS AF. The signal-noise ratio and the optical resolution can be reduced in this way.

### 17.13.5 Optimum Lifetime Information

In order to obtain the optimal lifetime information, it is in general preferable to scan FLIM images with fewer pixels than standard intensity "only" images, as the accuracy of the lifetime information is directly dependent on the number of photons per pixel. That may become crucial if several lifetimes are present. Furthermore, the calculation time of a lifetime image increases linearly with the number of pixels in the image. However, the SymPhoTime software also enables you to perform post-acquisition pixel binning for optimization of the best compromise between lifetime accuracy and resolution.

## 18 F(L)CS Data Acquisition

With the TCS SP8 SMD, you can carry out point measurements and FCS and FLCS data acquisitions are possible.

With sensitive detectors such as APDs, FCS measurements can be carried out. In all point measurements, the fluorescence is recorded at a certain position in the specimen and analyzed in the SymPhoTime software.

If no pulsed lasers are attached to the system or if lifetime information is not needed, continuous wave lasers from TCS SP8 can be used for the fluorescence excitation.

### 18.1 Preparing the FCS Measurement

This chapter includes steps that are helpful in preparing for an FCS measurement, not the description of the FCS measurement itself. That information can be found in **Chapter 18.2** to **Chapter 18.4** and in **Chapter 19**.

#### 18.1.1 Selecting an Objective

- Select a suitable objective: Since with FCS variations the focus size and shape have a particularly significant impact, we recommend using water immersion objectives for in vitro assays and in vivo experiments.
- For good FCS results, adjust the cover slip thickness with the correction ring (if available with the objective used).
- Select an objective with a high numerical aperture in order to maintain the smallest possible observation volume and yet to collect as many emitting photons as possible. We recommend the water immersion objective **HCX PL APO 63x/1.2W CORR CS 0.14 to 0.18** with manual or motorized correction ring. This objective functions exclusively with specimen slides or (glass-bottomed) measurement chambers that are 140 µm to 180 µm thick (e.g. cover slip types #1.0 or #1.5).

#### 18.1.2 Calibrating the Positioning Accuracy of the FCS Measuring Point

The measuring point is positioned via the scanner. Positioning accuracy can be optimized using a calibration function. Repeat this procedure about every 3 days. If you determine that the system is stable, you can also increase the time between fine-tuning sessions.

Use a bleach specimen with fixed fluorescence that is capable of being excited with a wavelength in the visible range and can also be photobleached with higher laser intensity. The bleach specimen may be a chroma slide (fluorescent dye that has been allowed to dry onto a cover slip), or you can mark the top side of a cover slip with a fluorescent marker.

1. Switch the confocal system on and start the LAS AF software as described in the instructions in **Chapter 14.1**. Select the conventional mode.
2. Activate the lasers in the **Configuration** step, **Lasers** button. Set the **Gain** for the argon laser to a value between 20 and 30 %.

3. Start the FCS Wizard by selecting the **FCS** operating mode (**Figure 153**). Using FCS is logical only if the software has not been started previously in resonant mode (**Resonant Scanner**).

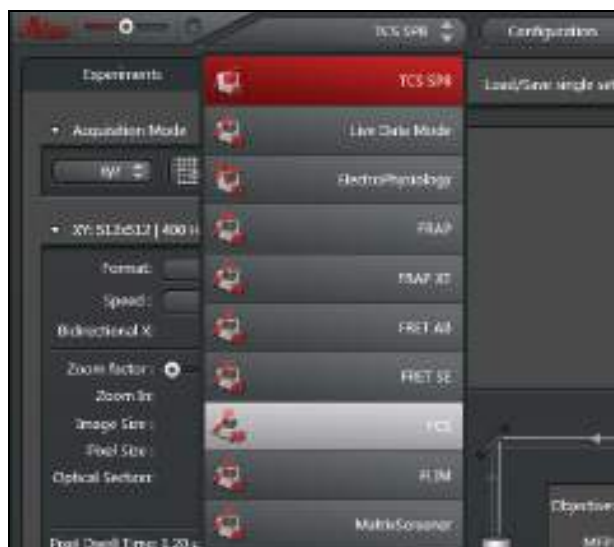

Figure 153: Opening the FCS Wizard in LAS AF

4. Select the **Setup Imaging** step (**Figure 154**, item 1).

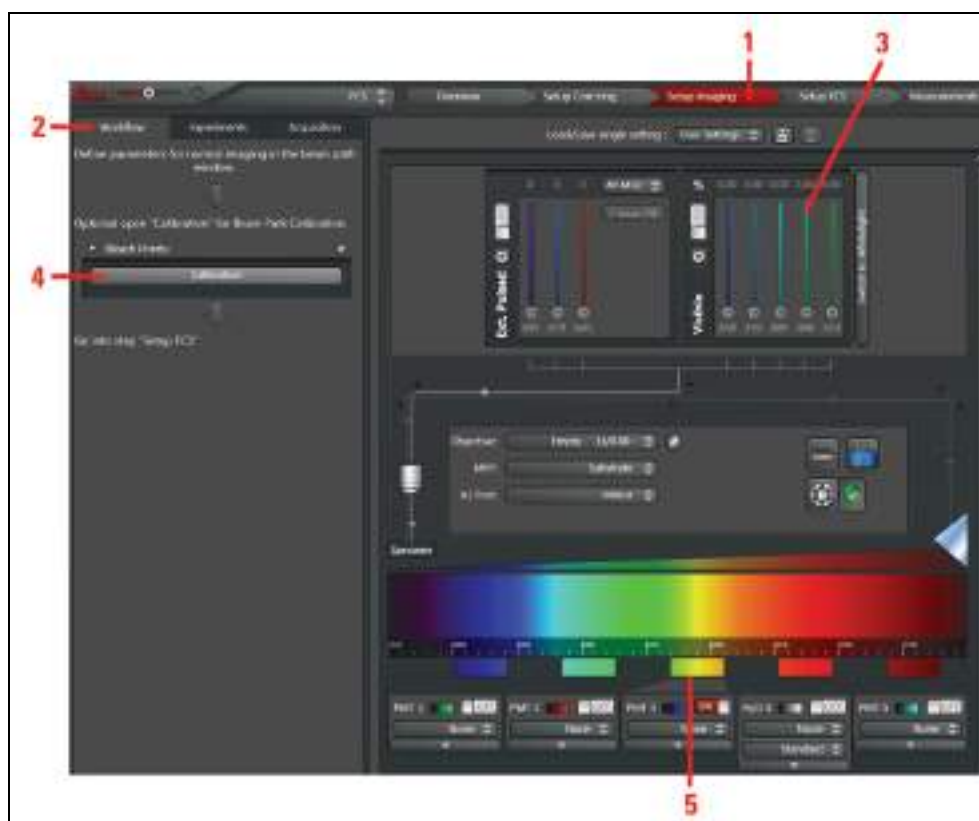

Figure 154: Calling up the procedure for calibrating the FCS measurement position in the FCS Wizard

5. Click the **Workflow** tab (**Figure 154**, item 2).
6. Focus on the bleach specimen.

7. Select one (or more) suitable laser line(s) (**Figure 154, item 3**) and a suitable detection range on the detector (**Figure 154, item 5**),
8. Then specify the **xyz** mode and a scan speed of 400 Hz for an image.
9. Select **Glow (O&U)** in the color look-up table (LUT).
10. Click **Calibration** in the pull-down menu (**Figure 154, item 4**).

A window appears for the calibration procedure (**Figure 155**). The system automatically determines the following values: Zoom 32 and pixel format 1024x1024.

11. Start a continuous scan by clicking the **Live** button (**Figure 155, item 1**) and manipulate the **Gain** and **Offset** on the control panel to obtain a well-illuminated image.

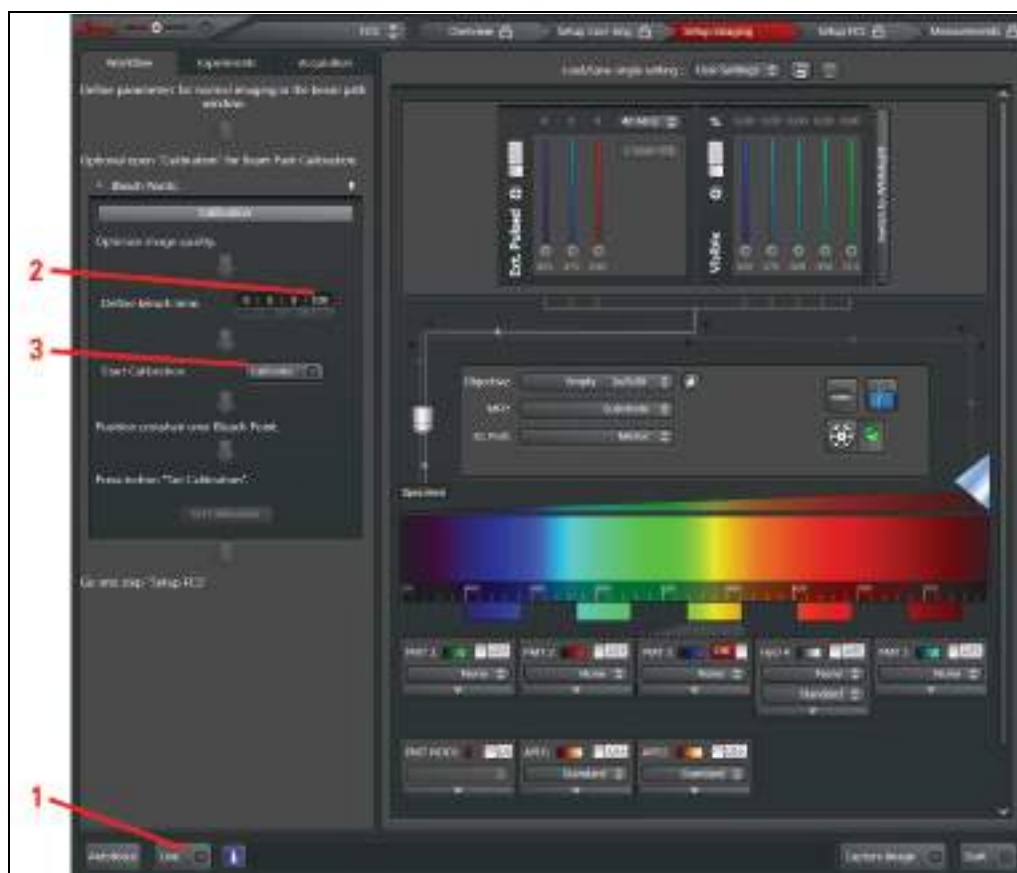

**Figure 155: Procedure for calibrating the FCS measurement position – Definition of instrument parameter settings**

12. With **Define bleach time**, enter the bleaching period; The default value is 100 ms (**Figure 155, item 2**). For thin and easily bleached specimens, it may be more useful to select a bleaching period of 500 ms or shorter.
13. Now select the **Calibrate** button (**Figure 155, item 3**).

An image will be acquired automatically. Then, the previously selected laser lines will automatically be set to 100% AOTF transmission for photobleaching, and the laser will bleach in the middle of the image for the set time. Then, another image will be acquired with the settings made previously.

14. Now position the crosshair in the middle of the bleach point (**Figure 156, item 1**) and

select the **Set Calibration** button (Figure 156, item 2).

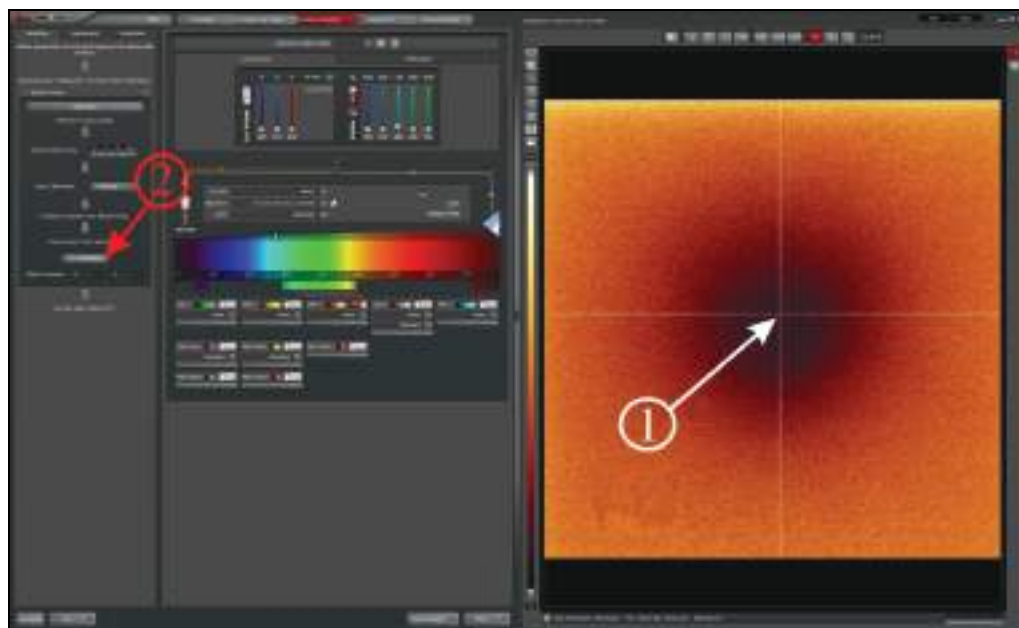

Figure 156: Procedure for calibrating the FCS measurement position – Definition of the bleach point

The calibration data will be stored by the system and displayed under **X** and **Y** (Figure 157).

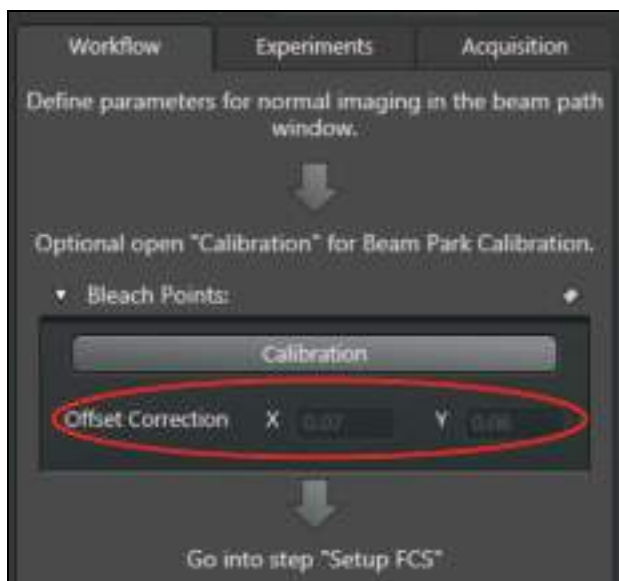

Figure 157: Display of the calibration data



#### Optimized calibration

The calibration is optimized primarily with regard to the scan speed defined during the calibration (default value: 400 Hz). The calibration applies for any zoom.

### 18.1.3 Testing the Positioning Accuracy

In order to test the positioning accuracy of the scanner on different pixels, the multipoint functionality for FCS can be used for a different purpose.

This test is not necessary to ensure the functional capability of the system as such; you use it only to confirm the performance capability of the system for yourself.

To carry out this test, proceed as follows:

1. Switch off all external detectors (the APD detector unit or the APDs with the DSN) electrically.
2. Start the SMD workstation.
3. Start the SymPhoTime software.
4. Create a new working area by selecting **New Workspace** in the **File** menu.



#### Observe the SymPhoTime manual

You will find information about creating a new working area in the SymPhoTime manual.

5. Using your bleach specimen, create a well-illuminated xy image as described in **Chapter 18.1.2** in the **Setup Imaging** step of the FCS Wizard. Use the photomultipliers for this (**Figure 154, item 5**). Use the zoom that you want to test. Use the same scan speed as the one you used previously when calibrating the scanner.
6. Select the **Measurements** step in the FCS Wizard (**Figure 158**).

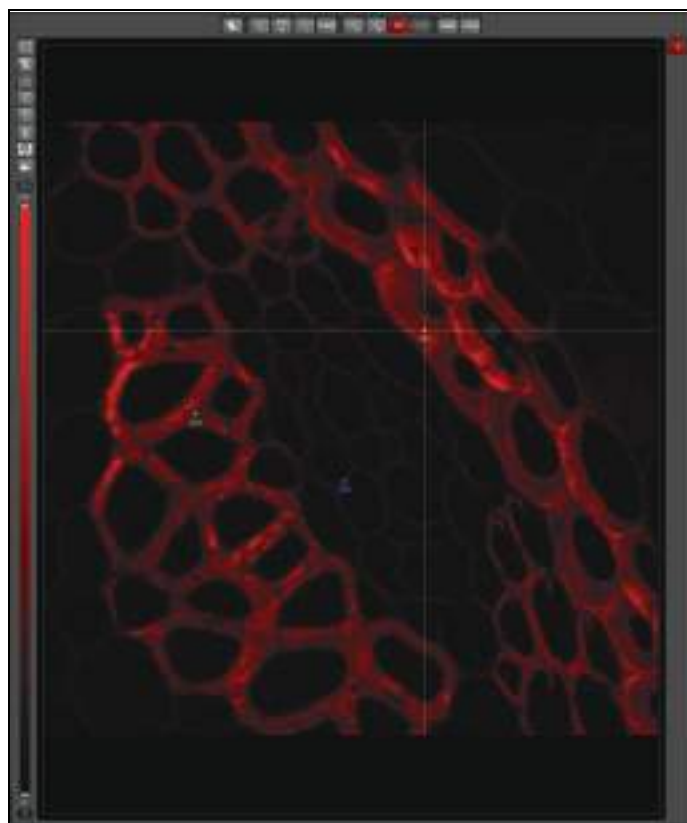

Figure 158: Testing the accuracy of the FCS measuring points – Setting the bleach points

7. Switch the APDs off electrically.
8. Select the initial bleach point in the xy image by clicking a point in the image display (Figure 158). Click the **Add** button (Figure 159, item 1).



Figure 159: Adding a bleach point and bleaching period

9. Select the next bleach point and click the **Add** button again. Continue until you have marked all the points you want.
10. Set the number of cycles to 1 by enabling the **Image after each \_ cycle** check box in the

**Setup** tab and enter **1** (**Figure 159, item 2**). This will automatically take a new image after photobleaching all points.

11. Set the laser used for photobleaching to 100%.
12. Under **Measurement Duration**, enter a suitable bleaching period; this will typically be a few seconds (**Figure 159, item 3**).
13. Start the bleaching series from LAS AF by clicking the image acquisition button **Run FCS**.
14. In the image acquired after photobleaching, compare the markings with the actual bleach points.
15. To archive your measurement, you can create a snapshot of the image with your bleach points. To do so, right-click this image and select **Snapshot**.

If the actual bleach points are not exactly what you want, repeat the calibration (**Chapter 18.1.2**).

#### 18.1.4 Adjusting the Correction Ring on the Objective

To guarantee the correct form of the detection volume, the correction ring at the objective must be adjusted to the thickness of the specimen slide below the specimen. You must always make this adjustment when you change the specimen carrier, even if it comes from the same batch. You should also repeat this adjustment if the temperature changes. Follow these steps:

1. Start LAS AF.
2. Use the objective **63x Plan APO 1.2W CORR CS 0.14 to 0.18**. Add immersion water to the objective and position the FCS specimen.
3. When you open the **Setup Corr-ring** step in the FCS Wizard, a preconfigured setting of the beam path is loaded. Adjust the settings as follows:
  - Select scan mode **xz-y** (z-Galvo).
  - Set the format to 512 x 512.
  - Set the zoom to the smallest possible setting.
  - Select the laser line at 488 nm.
  - Use bidirectional scan.
  - Set the AOBS to reflection.
  - Enable a SP PMT (no HyD and no SP FLIM PMT).
  - Adjust the detector range to detect the laser line as well.
  - Select **Glow (O&U)** in the color look-up table (LUT).
4. Click the **Live** image acquisition button.

A live image of the reflection line is displayed, which you can now optimize.

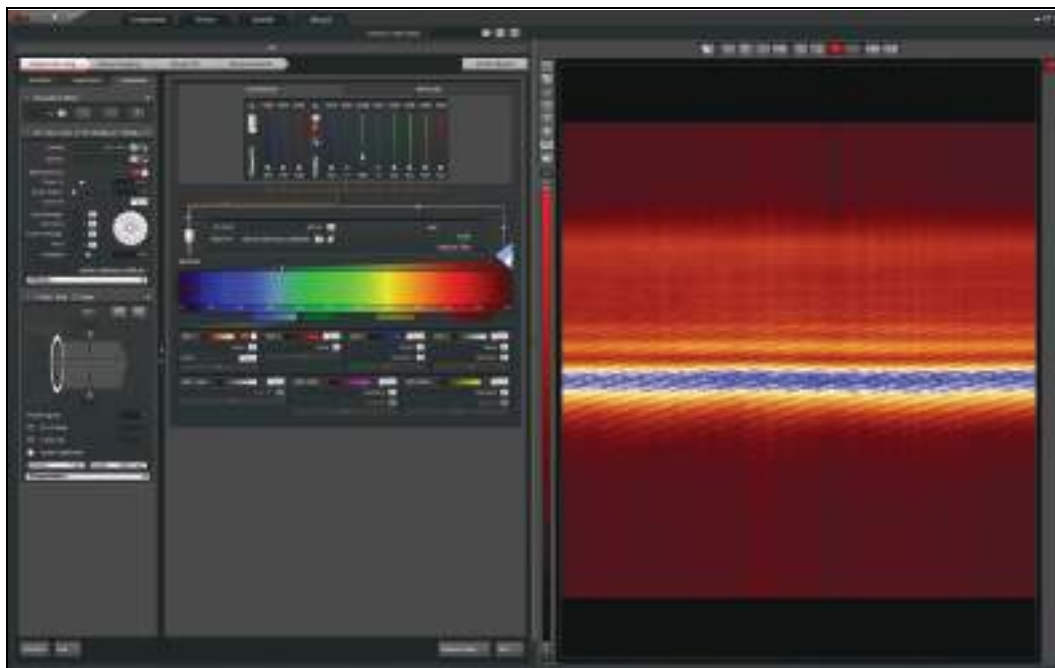

**Figure 160:** Optimization of the correction ring in the Setup Corr-ring step

5. Move the focus using the z-drive of the microscope stand until you see the two reflection lines that appear between the immersion and the glass and between the glass and the specimen (**Figure 161**, only visible simultaneously at zoom 1).

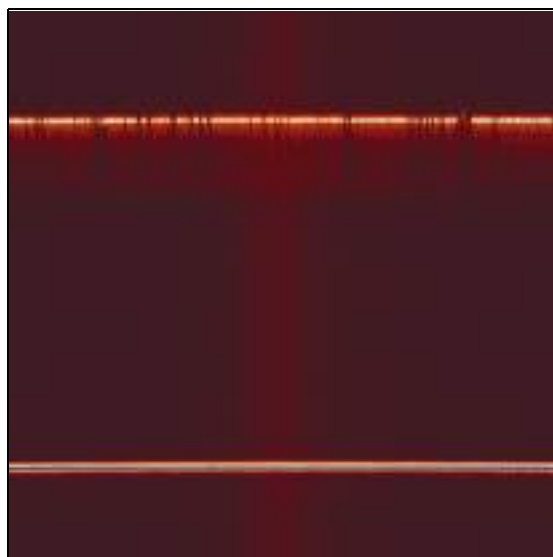
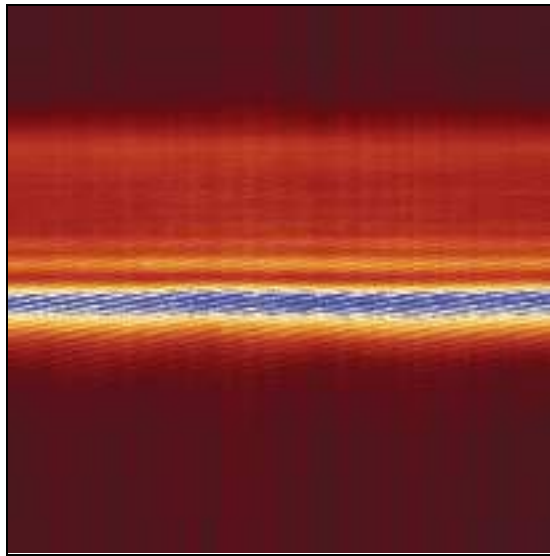

**Figure 161:** Reflection at the transition between the cover slip and the immersion water (top) and between the cover slip and the specimen (bottom) on the inverted stand. The objective is optimized relative to the bottom reflection. (The top and bottom reflection are simultaneously visible only for zoom 1. However, this can be set only if the objective cap was previously disabled in LAS AF.)

**Reversed image with inverted microscope**

Please note that with an inverted microscope the image is inverted. In this case, the bottom reflection (between glass and specimen) is the important signal that has to be optimized.

6. Go to a higher zoom (e.g. 4 to 8) and activate a continuous xz scanning operation with the **Live** image acquisition button.
7. Rotate the correction ring into a position that provides the highest contrast in the reflection between the cover slip and the specimen (greatest possible intensity and symmetry, narrowest possible intensity maximum without secondary maximum values; **Figure 162** and **Figure 163**).



**Figure 162:** Reflection between cover slip and measurement medium with poorly set position of the correction ring: The image is out of focus, several secondary peaks are visible

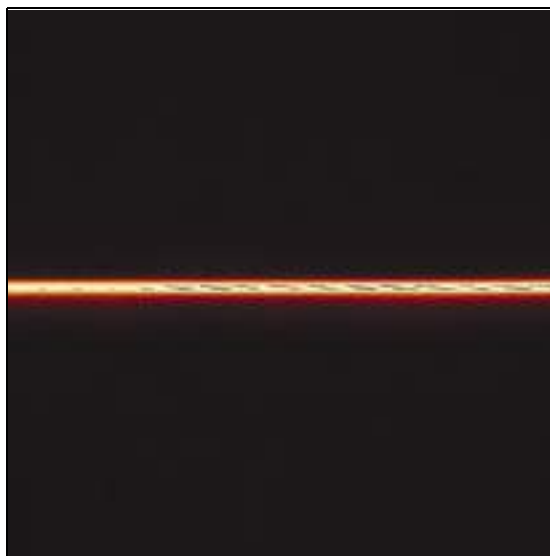

**Figure 163:** Reflection between cover slip and measurement medium with correctly set position of the correction ring: The image is sharp, and secondary peaks are scarcely visible

Repeat the correction ring adjustment whenever you insert a new FCS specimen.

### 18.1.5 Setting the Reference Position

When FCS measurements are taken in solutions, the measuring point must always be defined with the aid of a reference point. The reflection that is generated at the transition between cover slip and specimen serves as reference.

1. To do this, proceed as described in **Chapter 18.1.4**. Make sure that you obtain two reflections. On the inverted microscope, the upper reflection appears at the transition between the immersion and the cover slip; the lower reflection appears at the transition between the cover slip and specimen (**Figure 161**).
2. On the inverted microscope, place the reflection from the cover slip/specimen-transition approximately in the middle of the image.
3. Set the z-position to 0 on the stand.



#### Observe the user manuals for external lasers

Please refer to the information from the documents provided by the laser manufacturer for the external lasers. Pay particular attention to the laser manufacturer's notes!

4. Move the focus on the stand about 10-20  $\mu\text{m}$  towards the specimen (positive numbers on the inverted stand). The reflection on the inverted stand should move towards the top edge of the image (**Figure 164**).



**Figure 164:** Selection of the FCS measurement position for measurements in solutions: The reflection between the cover slip and the solution must be above the middle of the image.

### 18.1.6 Acquiring a Reference Image

For measurements in cells or other structures, you will need an image of your specimen. You can acquire this image in any step of the FCS Wizard. However, you can change the settings for image acquisition only in the **Setup Imaging** step.

### 18.1.6.1 Image Acquisition Using Photomultipliers

Normally, reference images of sufficiently bright signals are acquired using the internal photomultipliers; this uses the high dynamic range of these detectors.

1. Switch the acousto-optical beam splitter (AOBS) to fluorescence (**Figure 165**).

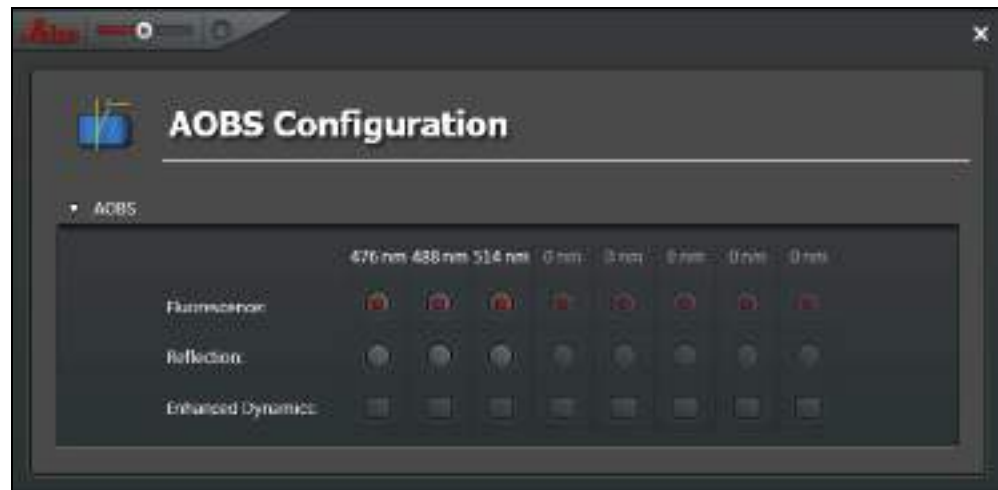

**Figure 165:** Dialog for AOBS configuration

2. Search for a region of interest in the specimen.
3. You can create an image or stack in the **Setup Imaging** step of the FCS Wizard (**Figure 166**). Select suitable photomultipliers (**Figure 166, item 2**) and the laser (**Figure 166, item 1**). You can also use an xyz or xzy stack.

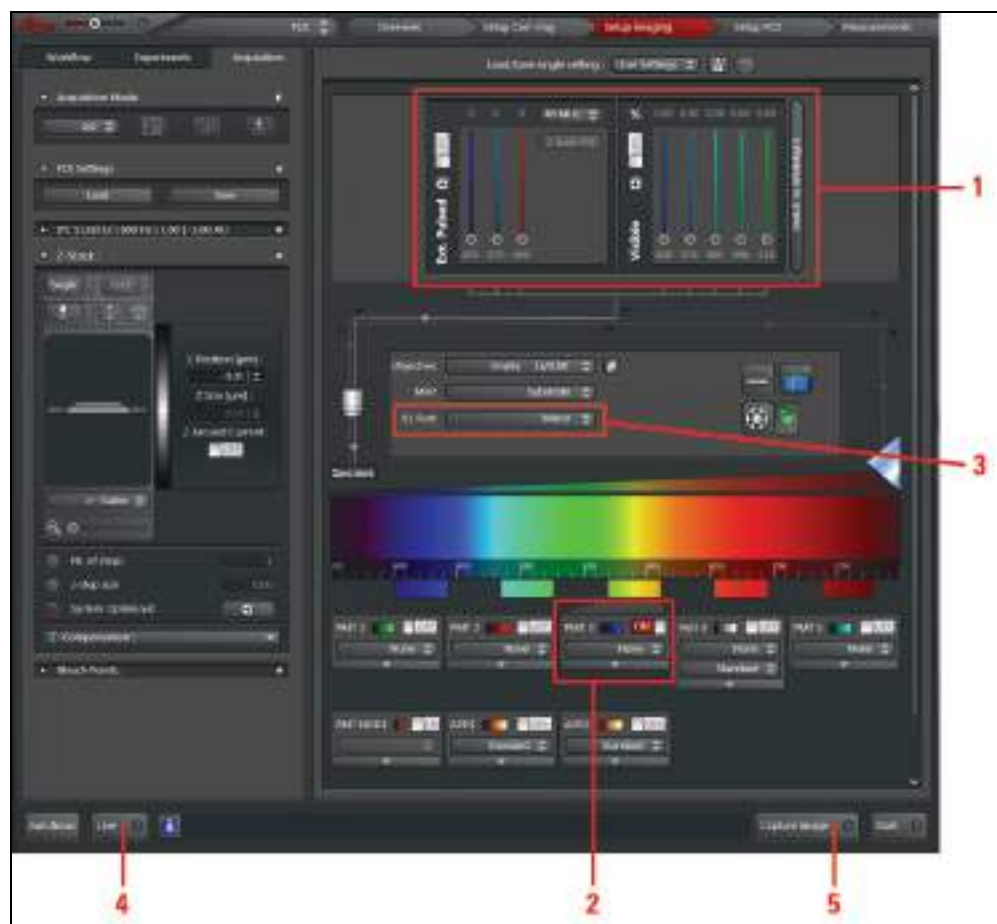

**Figure 166: Settings for acquiring a reference image using photomultipliers**

4. For a better comparison of the confocal image with the FCS measurement data, set the spectral detection window for image acquisition using the internal photomultipliers corresponding to the transmission of the SMD filter block used in the X1 port adapter. The laser lines and intensities for image acquisition may be the same as those for the FCS measurement, but they do not have to be.
5. Check that the external port X1 is switched to the **Mirror** position ( **Figure 166, item 3**).
6. Start a continuous scan by clicking the **Live** image acquisition button (**Figure 166, item 4**) and start an image acquisition by clicking the **Capture Image** image acquisition button (**Figure 166, item 5**).

### 18.1.6.2 Image Acquisition with PE APDs (AQR Type) or MPD APDs (PDM Type)

You can also acquire the image directly using the APDs. This procedure is recommended specifically for specimens with a low signal.

General recommendations for APD image acquisition:

- Slow scan speed (e.g. 10 to 100 Hz)
- Data accumulation (e.g. 4 to 8 frames)
- Best detection range for PE APDs: over 500 to approx. 800 nm, for MPD APDs: between 430 nm and 700 nm
- Adapt the scale of the color look-up table to the counting rate if necessary

1. First, switch on the APDs electrically.

**NOTICE** Light that is too intense may damage the APDs

Never switch on the APDs under illumination. Otherwise, the detectors can be damaged irreparably.

2. Now activate the detectors **APD1** and/or **APD2** (Figure 167, item 1) in **Beam Path Setting** of LAS AF. Set the external port X1 to --- (Figure 167, item 2).

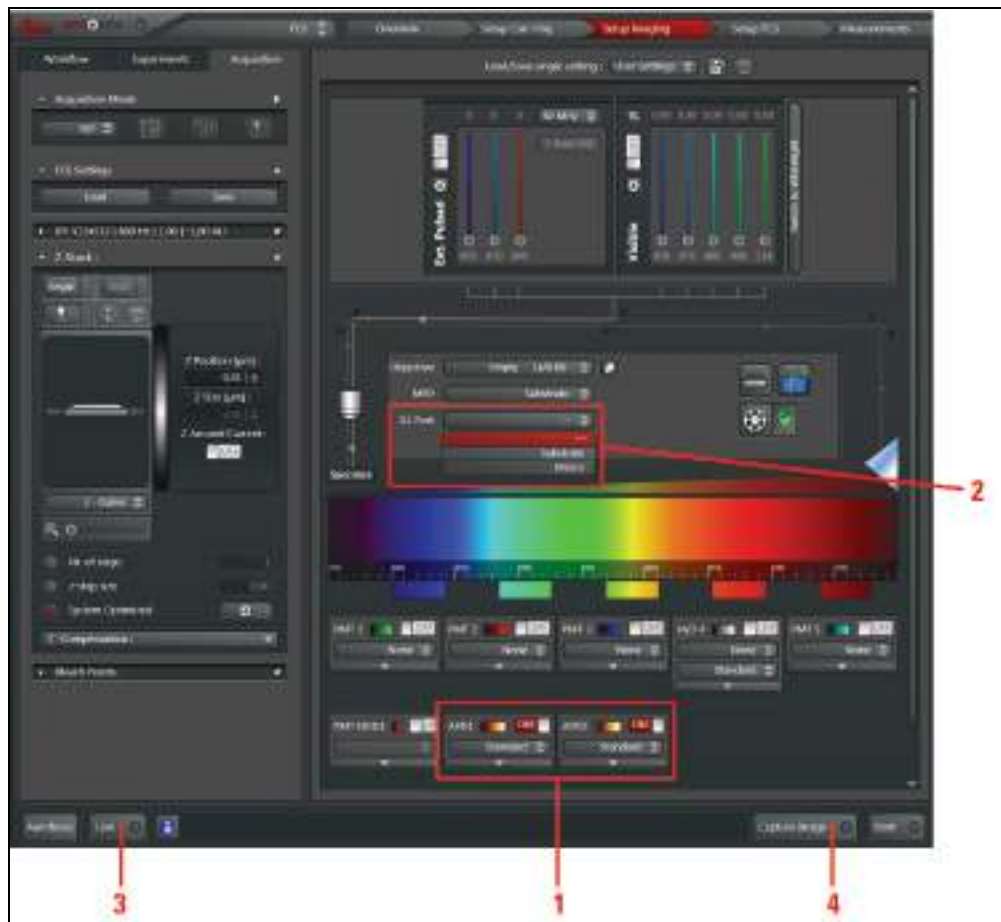

Figure 167: Settings for acquiring a reference image using APDs

3. If the audible warning signal for overload of the APDs sounds or the APDs shut off, reduce the illumination intensity immediately or switch off the APDs on the APD detector unit or on the DSN electrically. It is not sufficient to deactivate the APDs in **Beam Path Settings**.
4. Switch the MPD APDs back on manually. Activation of the MPD APDs takes about 20 seconds. The PE APDs switch on again automatically.
5. Start a continuous scan by clicking the image acquisition button **Live** (Figure 167, item 3) or start an individual image acquisition by clicking the image acquisition button **Capture Image** (Figure 167, item 4). Start with low laser intensity.

## 18.2 Setup Imaging Step – Image Acquisition

1. Start the FCS Wizard in LAS AF. To do so, open the operating mode selector and select **FCS**.
2. For applications in cells or tissues, in the **Setup Imaging** step you first create an xy scan of your specimen in the desired z plane, or you acquire an xyz stack (with z-Galvo).
3. If you would like to display a 'z-section' of your specimen, you can also acquire an xz image or an xzy stack. This might be especially of interest when working on membranes.

Other imaging modes (like time series or lambda stack) are not supported. The image acquisition procedure is the same as the general procedure without using the FCS Wizard.

### 18.2.1 Selecting Detectors for the Image Acquisition

You can use photomultipliers as well as APDs for the image acquisition. Photomultipliers are distinguished by having wide dynamic range; APDs are distinguished by higher detection quantum efficiency. PE APDs are distinguished by very good red sensitivity.

#### 18.2.1.1 Photomultiplier (PMT) / Internal Hybrid Detector (HyD)

1. Check that the external port X1 is switched to the **Mirror** position ( **Figure 166, item 3**).
2. In the beam path schema, activate the desired PMTs/HyD by clicking the appropriate check box.
3. Select the desired spectral range for detection.
4. Select low laser intensities.
5. You may also have to adapt the color look-up table (LUT). Click the color scale to call up the LUT selection dialog. There, you can select color look-up tables (LUT) for displaying the images to be acquired and create user-defined color look-up tables.
6. Optimize the image quality. The functions for this are the same as outside the wizard.
7. Acquire an image by clicking the **Capture** image acquisition button or acquire an xyz or xzy stack by clicking the **Start** image acquisition button. The start and finish of the stack are defined interactively, in the usual way. The stack image is automatically added to your LAS AF experiment.

#### 18.2.1.2 PE / MPD APDs

1. First, switch on the APDs on the APD or DSN control unit electrically.
2. Set the external port X1 (**X1 Port**) to the position --- (**Figure 168, item 1**).
3. Deactivate all photomultipliers in **Beam Path Settings**.
4. Activate the APDs by clicking the corresponding check boxes (**Figure 168, item 2**).
5. Select low laser intensities.
6. You may also have to adapt the color look-up table (LUT). Click the color scale to call up the **LUT Selection** dialog. There, you can select color look-up tables (LUT) for displaying the images to be acquired and create user-defined color look-up tables.  
You can also configure the intensity setting via **Gain** and the control panel. This function

has no effect on the detector; it modifies the color look-up table, which renders low-intensity structures more visible. It may also be helpful to accumulate over several images. The **Offset** setting on the control panel has no effect on the image.



#### Dependency of the spectral detection range of the APDs

The spectral detection range of the APDs is determined by the SMD filter cube used, not by the slider settings for the photomultipliers.

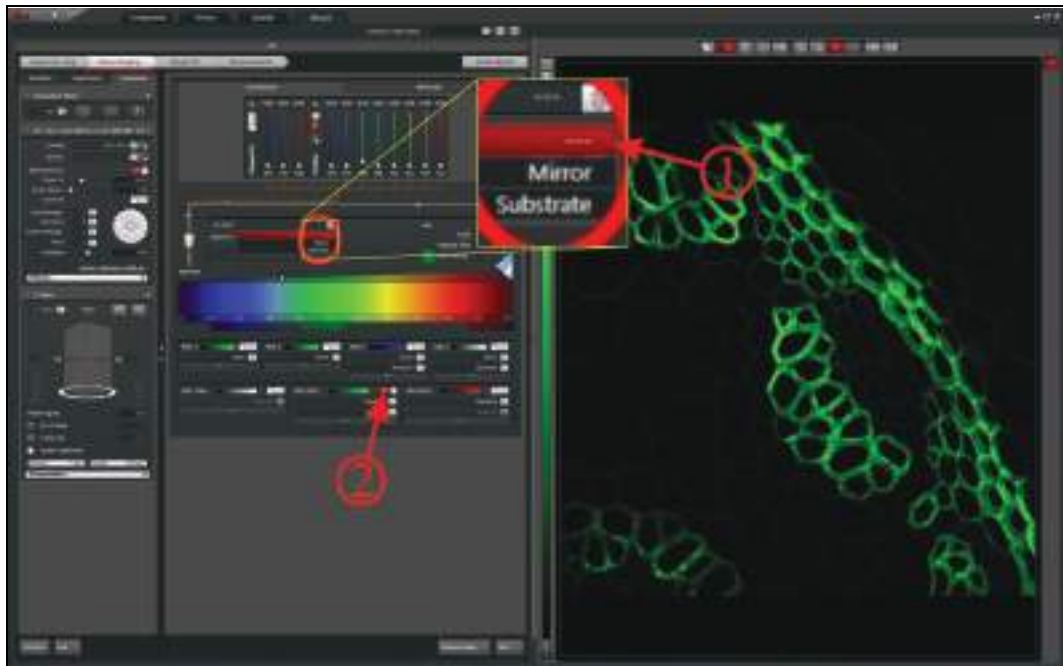

Figure 168: Acquiring the reference image using APDs, setting the X1 port

7. Optimize the image quality. The functions for this are the same as outside the wizard.
8. Acquire an image by clicking the **Capture** image acquisition button or acquire an xyz or xzy stack by clicking the **Start** image acquisition button. The start and finish of the stack are defined interactively, in the usual way. The stack image is automatically added to your LAS AF experiment.

## 18.2.2 Selecting Laser Lines as an Excitation Source for the Image Acquisition

All available lasers can be used for the image acquisition (**Figure 169**). You will find a description of the mode of operation in **Chapter 15**.

### 18.2.2.1 Using Continuous Wave Lasers

For capturing the emitted fluorescence, set the acousto-optical beam splitter to fluorescence (**Figure 169**). Choose a suitable laser line and adjust the intensity to the desired level using the AOTF slider. If the system has a multifunction port (**MFP**), it should be set to **Substrate**.



Figure 169: Acquiring the reference image using continuous wave lasers and photomultipliers

### 18.2.2.2 Using MP Lasers

1. For MP scanning operations, select the desired wavelength.
2. Choose a suitable neutral density filter for the attenuation using the **Trans** slider and/or adjust the electro-optical modulator (EOM) using the **Gain** and **Offset** sliders.
3. If the system has a multifunction port, it should be set to **SP680** or **SP700**.

For more detailed information about switching on the MP lasers, refer to **Chapter 15.1.2**.

### 18.2.2.3 Using Pulsed VIS Lasers

1. Close the shutter of the continuous wave VIS laser in **Beam Path Settings** and move all acousto-optical tunable filters to the 0 position.
2. Open the shutter for pulsed lasers (**Figure 170, item 1**).
3. Activate the desired laser by moving the corresponding slider upwards (**Figure 170, item 2**).



### Controlling laser intensity of the pulsed laser

For pulsed lasers, the slider does not affect the laser intensity. Laser intensity needs to be controlled at the desired laser.



Figure 170: Settings for using pulsed VIS lasers as excitation source

4. Check whether the correct beam splitter (**MFP**) is selected (**Table 18, page 123**).
5. You can use the pulsed VIS lasers together with the pulsed UV laser (405 nm). The MFP setting is not influenced by UV. It is defined by the selection of the pulsed VIS lasers.



### Combination pulsed and continuous wave VIS excitation

Do not use any pulsed VIS excitation together with continuous wave VIS excitation for continuous wave laser lines close to the wavelengths of the pulsed laser (such as the combination 470 nm pulsed + 488 nm continuous wave), as no optimum MFP setting exists for such a combination.

#### 18.2.2.4 Using a Pulsed UV Laser

1. Open the shutter for pulsed lasers.
2. Activate the 405-nm laser by moving the corresponding slider.
3. If no other pulsed laser is used, you can set the multifunction port (**MFP**) to **Substrate**.



### Positioning the multifunction port

Within the FCS Wizard, positioning of the multifunction port is automated; outside the wizard, it must be set by the user. The automatic configuration can be changed subsequently by the user.

For more detailed information about using the pulsed UV laser, refer to **Chapter 15.1.4**.

## 18.2.2.5 Using White Light Lasers

1. Select the desired laser lines in the **Whitelight** dialog in **Beam Path Settings**.
2. Make sure that the AOBS is at fluorescence.
3. Set the desired intensity using the AOTF slider.
4. If the system has a multifunction port (**MFP**), it should be set to **Substrate**.
5. Open the **Acquisition** tab and adjust the rotation to  $0^\circ$  using the slider (**Figure 171, item 1**).

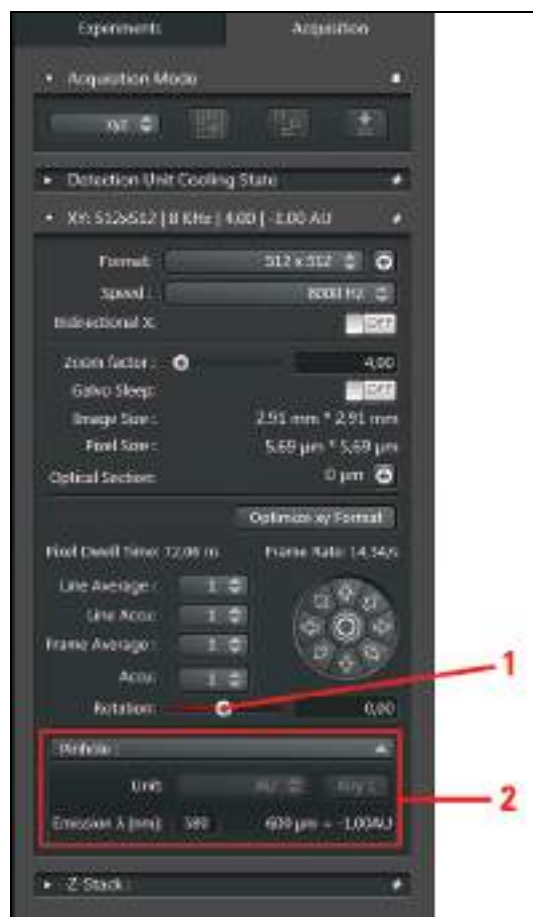

Figure 171: Adjusting the diameter of the pinhole and rotation

## 18.2.3 Adjusting the Pinhole for Image Acquisition

For VIS and UV excitation, set the **Pinhole** diameter to **1 Airy**; for MP excitation set it to the maximum size (**Figure 171, item 2**).

## 18.3 Setup FCS Step – Optimizing FCS Measurement Conditions

1. Open the **Setup FCS** step in the FCS Wizard.
2. Now set the instrument parameters for an FCS measurement.



### Do not change Acquisition mode any more

Do not make any more changes to the **Acquisition mode** (xyz or xz) used in the last image. The positioning of the FCS point must be set in the same mode as the most recently acquired image.

### 18.3.1 Selecting APDs

The APDs are external detectors. For FCS, they do not have to be activated specially in the software.

1. Switch the APDs on electrically.
2. If you do not receive a signal after starting a test measurement, check that the external port (**X1 Port**) is set to ---.

Activation/deactivation of individual detectors in **Beam Path Settings** and settings for the spectral sliders for the photomultipliers are not relevant for the FCS measurement.

### 18.3.2 Selecting Laser Lines for FCS

Typically, FCS measurements are carried out using continuous wave VIS laser lines. UV laser lines are not specified and are also not recommended due to the reduced quantum efficiency of the APDs in the blue spectrum.

Furthermore, MP excitation is not specified for FCS. Pulsed visible lasers (diode lasers, white light lasers) can be used for time-resolved FCS measurements, like FLCS or gated FCS.

#### 18.3.2.1 Using Continuous Wave VIS Lasers

1. Choose a suitable laser line and laser intensity by setting the AOTF slider.
2. The acousto-optical beam splitter must be set to fluorescence.
3. In front of the argon laser, there is an FCS filter wheel for additional clean up of selected laser lines and for further attenuation. When selecting a laser line by the AOTF setting, the FCS filter wheel is automatically moved to the right position. You can check the position in the pull-down menu from **Filter Wheel** in **Beam Path Settings (Figure 172)**. Other laser lines are not affected by the FCS filter wheel.



**Figure 172: Controlling the FCS filter wheel**

Due to the configuration of the FCS filter wheel, the following laser lines are not available for FCS and are therefore grayed out in the software (**Figure 172**):

- 476 nm
- 496 nm

The following combinations are also not possible (although the individual lines can be used on their own):

- 458 nm with 488 nm
- 488 nm with 514 nm

The combination of 458 with 514 nm can be used, however.

The FCS filter wheel is used only in the **Setup FCS** and **Measurements** steps of the FCS Wizard. In all other cases it is in an empty position. This means that all argon laser lines used in the FCS measurement (**Setup FCS** and **Measurements** steps in the FCS Wizard) are attenuated for the image acquisition relative to the normal mode: The 458-nm line is attenuated by 25 percent, the 488-nm line by 75 percent, the 514-nm line by 75 percent, and the combination of 458 and 514-nm lines by 50 percent. The other lasers are not affected by attenuation.

### 18.3.2.2 Using Pulsed VIS Diode Lasers

For FCS, the pulsed diode lasers can be used in the VIS range. The observation volume and therefore the diffusion time are greater than when using the continuous wave lasers.

For what comes next, follow the instructions in **Chapter 18.2.2**.

### 18.3.2.3 Using White Light Lasers

The white light laser can be used for FCS. The signal-noise ratio is optimized when you select laser lines that are available in the fluorifier disc and position the filter wheel accordingly (**Chapter 16.2.3**). If you want to adjust other laser lines, the distance between displayed laser wavelength and detection range (FWHM) should be  $>12$  nm.

Unlike FLIM and FLCS, with FCCS you can also use two white light laser excitation lines. For systems with a pulse picker, we recommend operating the laser for FSC and FCCS measurements at the maximum frequency (80 MHz). For FLCS, the recommended frequency is 40 MHz.

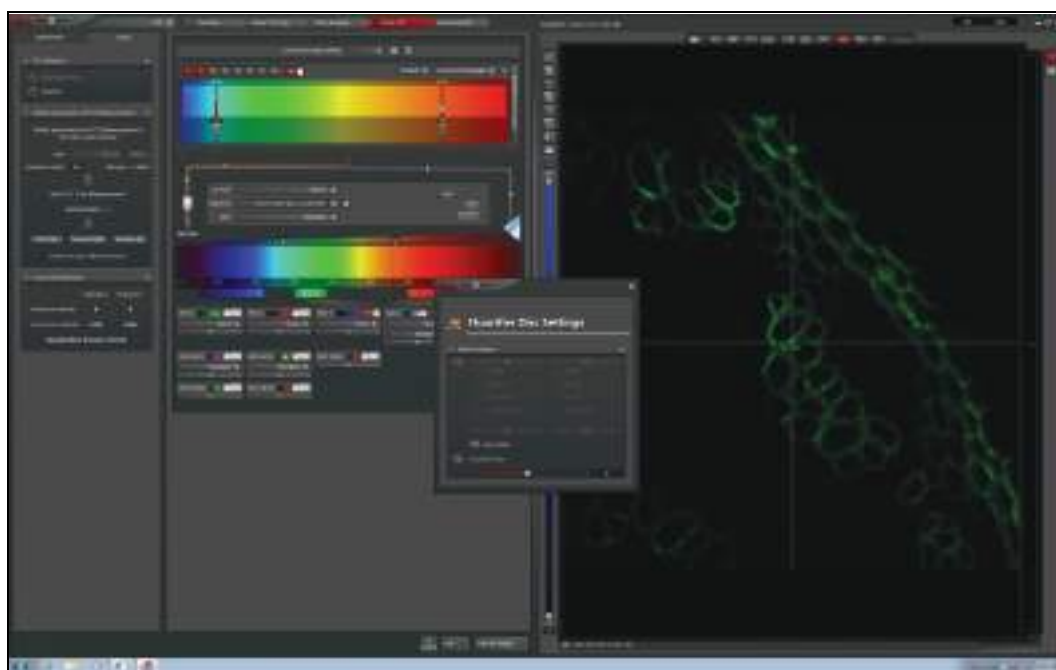

Figure 173: Setting of an FCCS measurement with the white light laser as excitation source

### 18.3.3 Fluorifier Disc

Most SMD FCS systems have a fluorifier disc. If there is such a fluorifier disc, select a barrier filter as described in **Chapter 16.2.3**. You can open the **Fluorifier Disc** dialog in **Beam Path Settings**.

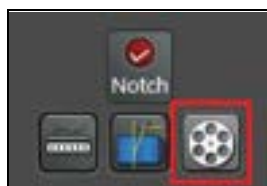

Figure 174: Fluorifier Disc button in Beam Path Settings

### 18.3.4 Setting the Pinhole

Set the **Pinhole** diameter in the **Setup** tab to **1 Airy**.

### 18.3.5 Optimizing FCS Settings



#### A scanning operation is required before an FCS measurement

After starting LAS AF, at least one scanning operation has to be carried out (using **Live** or **Capture**) before an FCS measurement can be started. This is also necessary when working in solutions only. Otherwise, no FCS measurement is started.

1. First, use the image display to find a measuring point in the image. Move the crosshair in the image display to the desired position (**Figure 175**).

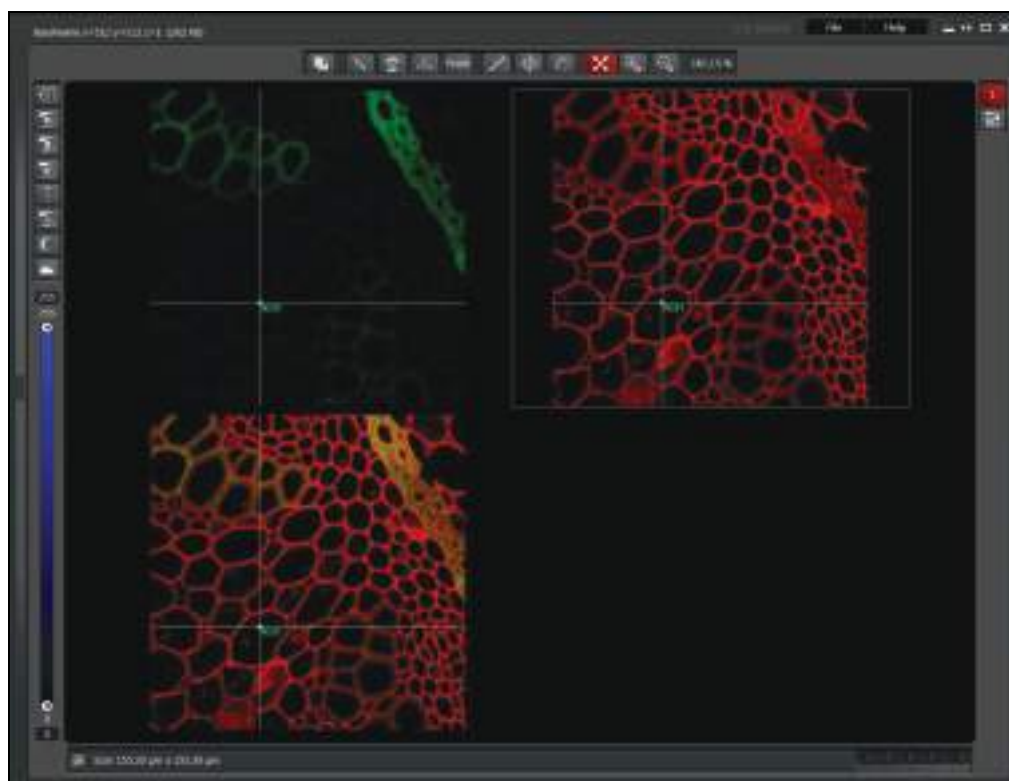

**Figure 175:** Selecting the measuring points

2. Press the **Run FCS Test** button (**Figure 176, item 1**) on the **Setup** tab to start the illumination. You can view and optimize the fluorescence intensity in the count rate monitor. Laser line and intensity can be modified during the test measurement until you attain the count rate or counts per molecule desired.
3. The scanner cannot be moved out of its defined position while **Run FCS Test** is still active. To move the scanner to another position, you first have to stop the FCS measurement by clicking the **Stop FCS Test** button.
4. Then, move the crosshair to the desired position and restart the measurement by clicking the **Run FCS Test** button.

When you start the test measurement, an online correlation curve is displayed in SymPhoTime.



### Saving the data in Measurements

This curve is not saved. If you want to save your data, you have to work in the **Measurements** step.



Figure 176: Starting the FCS test and applying the measuring point

5. To end illumination of the specimen, click the **Stop FCS Test** button in LAS AF. This will also stop the online correlation display in SymPhoTime.
6. If you would like to reuse a tested FCS measuring point later for the 'correct' FCS measurement, click **Add Point** (Figure 176, item 2) in the **Setup** tab. This measuring point is then written to a position list, which is used in the **Measurements** step in LAS AF. Do not make any more changes to the zoom. Changing the zoom in the **Setup FCS** step would render the position list invalid.

The instrument parameters set for the FCS measurements (laser lines and associated intensity, pinhole, AOBs) are kept as separate FCS settings that are independent from the image acquisition setting defined in the **Setup Imaging** step. The FCS settings defined in the **Setup FCS** step are automatically transferred to the **Measurements** step.

## 18.3.6 Count Rate Monitor

The count rate of each channel is displayed in the **Setup** tab. For FCS, the count rate should be between 10,000 and 500,000 cps (counts per second).

If the two detection channels are reversed, change the allocation in SymPhoTime. The allocation of the channels is preset and should not be changed.

- FCS Channel A: Check box 1
- FCS Channel B: Check box 2

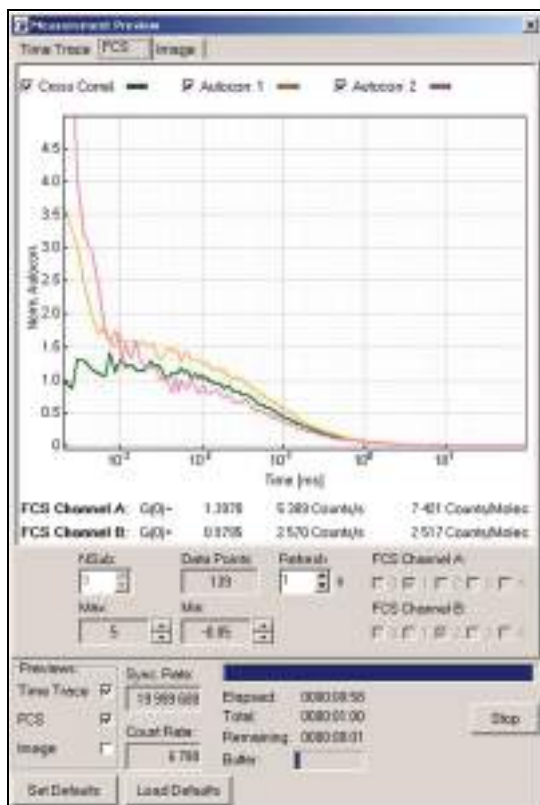

Figure 177: Measurement Preview in SymPhoTime: Allocation of the FCS channels

Defaults can be saved using the **Set Defaults** button.

In addition to the count rate (cps), the count rate per molecule (cpm) is displayed in the count rate monitor in LAS AF. It is calculated from the online correlation. Since FCS is based on fluctuation analysis, it is normal for these values to fluctuate. The higher this value, the better the signal/noise ratio of the correlation curve. That means this value should be maximized (by selecting an appropriate fluorescent dye, a suitable laser intensity, a suitable dye concentration, the correct setting for the objective's correction ring, etc.).

To prevent saturation effects, select the laser intensity with which you can reach approximately two-thirds of the maximum count rate per molecule. If you then observe photobleaching or an excessively high triplet fraction, continue to reduce the laser intensity.

### 18.3.7 Loading and Saving FCS-specific Instrument Parameter Settings

FCS-specific instrument parameter settings (IPS) are organized in a different way than image acquisition settings. Therefore, they are managed separately from the image acquisition settings. On the one hand, this means that FCS instrument parameter settings can be loaded and saved only in the **Setup FCS** step; they are not available anywhere else (**Figure 178**). On the other hand, it means that image acquisition settings are not available in the **Setup FCS** step. They must be loaded and saved in the **Setup Imaging** step or outside of the FCS Wizard.

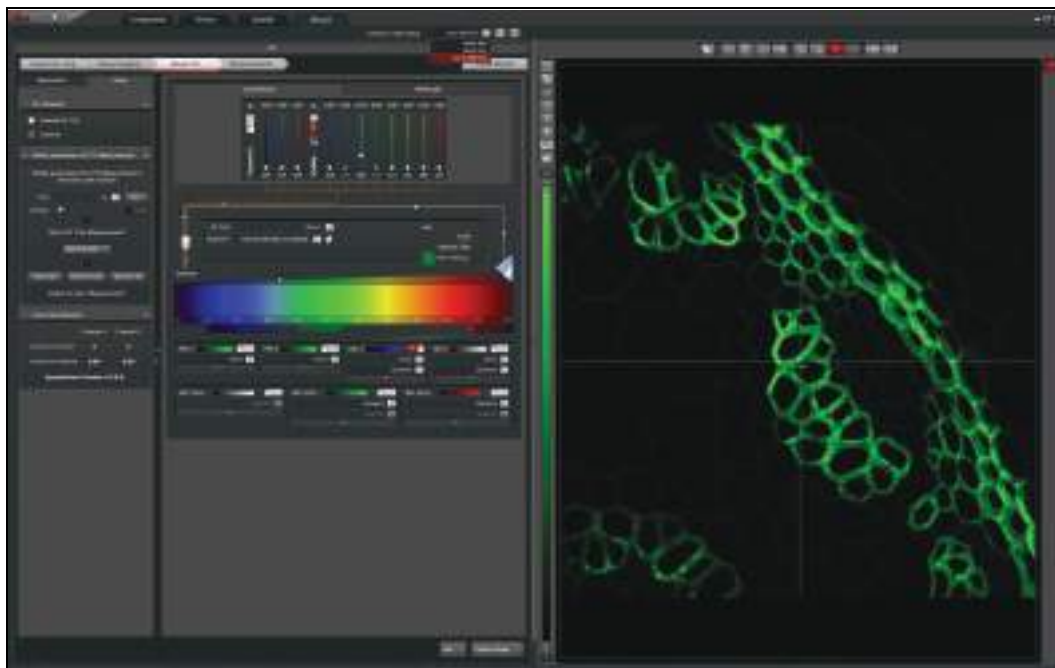

Figure 178: Loading and saving FCS-specific instrument parameter settings

## 18.4 Measurements Step – FCS Measurement Time Series at Multiple Points

After optimizing the FCS measurement conditions, it is possible to have FCS measurements run automatically at previously defined measuring points with the previously defined settings. To do so, go to the **Measurements** step.



### Do not change Acquisition mode any more

Do not make any more changes to the **Acquisition mode** used to acquire the last image.

### 18.4.1 FCS Network Connection

The LAS AF and SymPhoTime programs are synchronized via a network connection. Each FCS measurement started in LAS AF in the **Measurements** step of the FCS Wizard generates a new data file in SymPhoTime. In addition to the synchronization, the network also enables transmission of relevant information such as the file name, instrument parameter settings (IPS), or comments entered by the user in LAS AF.

During the FCS measurement, an online correlation curve is displayed that is automatically saved along with the raw data in SymPhoTime. After the data acquisition, a more detailed data analysis can then be carried out offline.



### Observe the SymPhoTime manual

For more detailed information about data analysis, refer to the SymPhoTime manual.

## 18.4.2 Definition of Multiple FCS Measuring Points in an Image or Stack

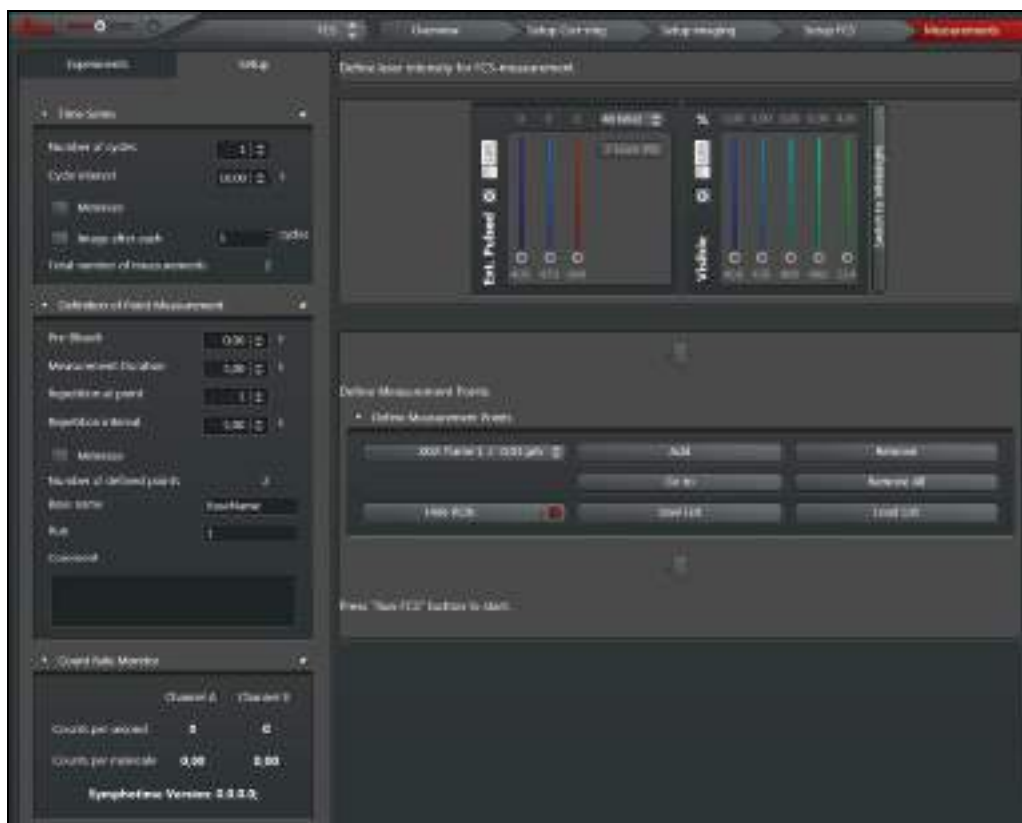
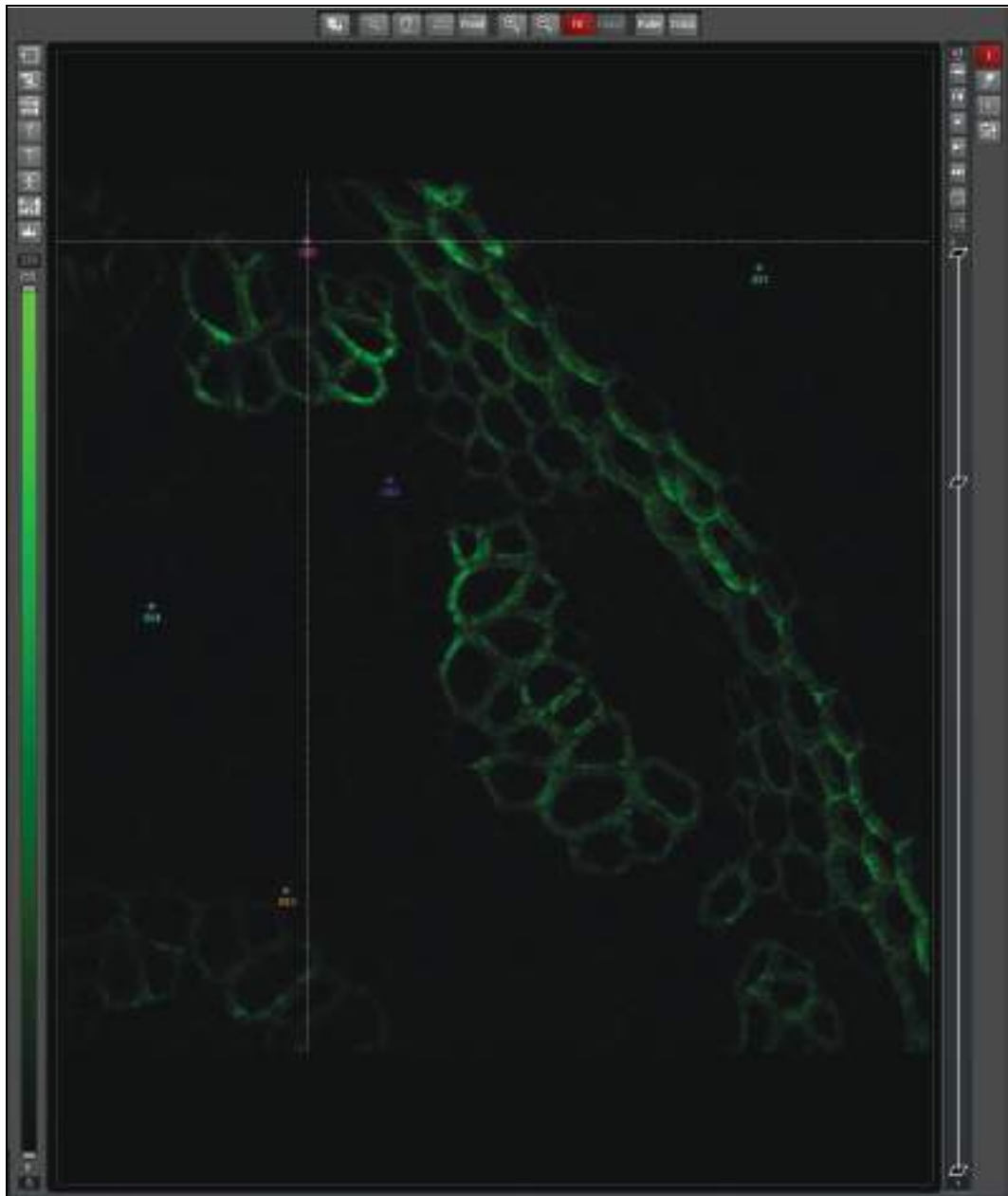

Figure 179: Overview of the Measurements step in the FCS Wizard



**Figure 180:** Setting of multiple FCS measuring points in a previously acquired xyz image stack

To set the FCS measuring points for FCS measurement time series, proceed as follows:

1. Take an xy or xz image or take an xyz or xzy stack.
2. Select the instrument parameter setting for the FCS measurement in the **Setup FCS** step.
3. Move to the **Measurements** step in the FCS Wizard. If necessary, you can fine-tune the laser intensity here (**Figure 179**).
4. In the **Experiments** tab, check that the current image or xyz or xzy stack has been activated.
5. Select the first measuring point in the image or stack in the image display.
6. Click **Add (Figure 179)**.
7. To document the measuring point, right-click in the image and then click **Snapshot**.

8. Select the next measuring point, click **Add**, and create another snapshot as necessary.
9. Continue until you have marked all the points you want. The maximum number of points is 200.
10. Different measuring points in an xyz or xzy stack can be located on different z or y planes, respectively. Select the z or y planes you want in the image display. Place the crosshair on the xy point you want in the desired z plane or xz point on a certain y position.
11. Then click **Add (Figure 179)**.
12. After this, a position list is created that can be saved by selecting **Save list** and called up at a later time (**Figure 179**). Individual points can be deleted from the list with **Remove**, and the entire list can be deleted with **Remove all (Figure 179)**.
13. Enter a measurement time in the LAS AF software, that is, the time required for a single measurement (**Figure 179**).
14. The selected measurement duration and the instrument parameter setting for the FCS measurement are applied to all individual measuring points.
15. If you are working in xyz mode, you can still change the zoom within the **Measurements** step.



#### **Do not leave the Measurements step until FCS data acquisition**

You may no longer leave the **Measurements** step until the FCS data acquisition, otherwise the position list becomes invalid.

### 18.4.3 FCS Time Series at Multiple Measuring Points

In the **Setup** tab, it is possible to define a time series in two ways:

- Repeated measurements at single points (definition in the **Definition of Point Measurement** field)
- Repeated processing of all points (definition in the **Time Series** field).

By combining both kinds of definition, a time series can be created within a time series.

For repeated measurement at individual points, the following functions are available:

- **Pre-bleach**: Enables you to define a time in which the laser is switched on before the measurement begins. This feature can be used to pre-bleach the specimen before the measurement (**Figure 181, item 1**).
- **Measurement duration**: Specifies the duration of an individual FCS measurement (**Figure 181, item 2**). The minimum measurement duration is 1 second; the maximum measurement duration is 10 minutes.
- **Repetition at point**: The entered number specifies how often the measurement at this point is repeated before the system moves on to the next point (**Figure 181, item 3**). The maximum number of repetitions is 1000.
- **Repetition interval**: Specifies the time between the beginning of one measurement and the following measurement at this point. The value cannot be smaller than the sum of measurement and pre-bleach time (**Figure 181, item 4**).
- **Minimize**: If the **Minimize** box is checked, repetitions will be carried out as fast as possible (**Figure 181, item 5**).

- **Number of defined points:** The user does not have access to this field. It serves to visualize the number of measuring points defined in the viewer (**Figure 181, item 6**).

The maximum number of FCS measurements in a measurement series is 1000.

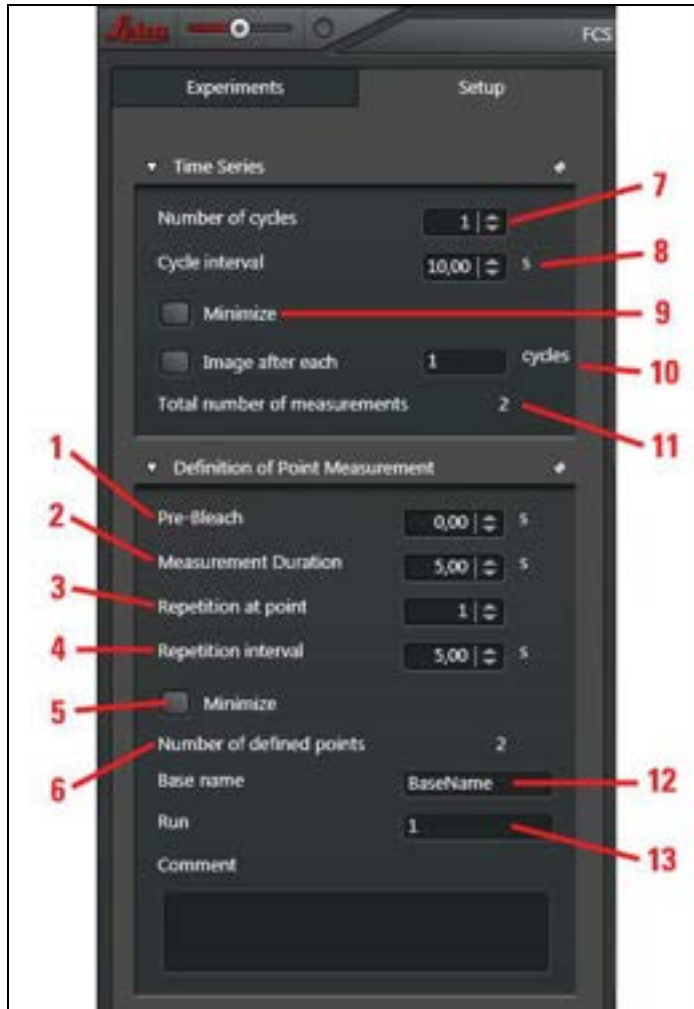

**Figure 181: Definition of an FCS Time Series**

The following functions are available for repeated processing of all points:

- **Number of cycles:** A **Cycle** means that, in the sequence of their definition, the individual measuring points are processed exactly once in the image display with the number of repetitions specified in the **Definition of point measurements** dialog. The input field enables you to specify the repetitions to be carried out relative to a complete cycle (**Figure 181, item 7**). The maximum number of cycles is 1000.
- **Cycle interval:** Specifies the time between the beginning of one cycle and the next cycle (**Figure 181, item 8**). If the **Minimize** box is checked, processing cycles will be carried out as fast as possible (**Figure 181, item 9**).
- **Image after each \_\_\_ cycles:** If you enable check boxes and enter the number **1**, an image or stack is acquired with the current image acquisition settings after each cycle. If you enter the number **2**, an image or stack is acquired after every second cycle; if you enter **3**, after every third cycle, and so on. After processing all cycles, one last image or stack will be acquired (**Figure 181, item 10**).

- The user does not have access to the **Total number of measurements** field. It serves to visualize the number of FCS measurements carried out (**Figure 181, item 11**). This number is the product of **Number of defined points** times **Repetition at point** times **Number of cycles**.

The maximum number of FCS measurements in a measurement series is 1000.

Start the measurement series in LAS AF by clicking the **Run FCS** image acquisition button.

#### 18.4.4 Definition of the File Names Transferred to SymPhoTime during the FCS Measurement

You can specify the name of the FCS data file used in SymPhoTime in the **Setup** tab in the **Definition of point measurement** field (**Figure 181, item 12**).

The following functions are available:

- Whenever a series of FCS measurements is started, SymPhoTime generates a folder that houses all FCS measurement files of this series. The name of the folder is composed as follows:
  - **BaseName\_Run**  
**Base name:** Enables you to specify the base folder and file name used in SymPhoTime (**Figure 181, item 12**). If the user does not enter a name, **BaseName** will be automatically used.  
**Run:** This is a suffix that is added to the file names transferred in SymPhoTime. In SymPhoTime, no two folders may have the same name. Therefore, the number given in the **Run** suffix is automatically increased by one whenever a measurement series is started. The **Run** suffix can be changed by the user (**Figure 181, item 13**).



##### Do not use the same name

Do not enter the same **BaseName\_Run** name twice. This will create an error message.

- The file name uses the same **BaseName** and **Run** components as the folder. Additionally, LAS AF will automatically add some more suffixes to the file name that contain the following information:
  - **Cycle**
  - **Measuring point**
  - **Repetitions at this point**

The file name structure is as follows:

- **BaseName\_Run\_Cycle\_Measuring point\_Repetition**
- The **Measuring point** number is identical to the number used in the image display.

These additional suffixes cannot be modified by the user.

- If **Image after each \_\_ cycles** is enabled, an image or stack is automatically saved in LAS AF with the following name:  
**BaseName\_Run\_Cycle**

This makes it easier to allocate the images in LAS AF to the corresponding FCS data in SymPhoTime.

## 18.4.5 FCS z-Stack

An FCS z-stack can be particularly useful for FCS measurements on membranes. To create an FCS z-stack, follow these steps:

1. First acquire an xyz stack in the **Setup Imaging** step in the FCS Wizard (**Chapter 18.2**).
2. If necessary, optimize the measurement conditions in the **Setup FCS** step (**Chapter 18.3**).
3. Change to the **Measurements** step.
4. Use the image display to find the xy point in the z image stack at which you want to generate the FCS z-stack.
5. In the z image stack, go to the top z plane that is of interest to you. Click on the desired xy position and then on **Add** in **Beam Path Settings (Figure 179)**. Go to the plane below; do not change the xy position, but click **Add**. Then go to the plane below that, etc. Continue until you reach the lowest plane that is of interest to you.  
If you wish, you can also acquire the z FCS stack from the bottom upwards.
6. Define the measurement duration, the number of repetitions at each point, and the number of cycles as described in **Chapter 18.4.3**. The FCS instrument parameter settings are identical at all measuring points.
7. Specify folder and file names as described in **Chapter 18.4.4**.
8. Click the **Run FCS** image acquisition button in LAS AF.

The maximum number of FCS measurements in a measurement series is 10,000.

### 18.4.6 Operating the FCS Measurement Series

The measurement series is started by clicking **Run FCS** image acquisition button. It stops automatically after all measurements are taken. A user-defined stop is possible by clicking **Stop FCS (Figure 179)**.

In the count rate monitor (**Figure 179**), the current count rate (in cps – counts per second) of each channel as well as the counts per molecule (in cpm – counts per second per molecule) are displayed during the individual measurements.

In SymPhoTime, an online correlation curve is displayed and saved together with the raw data.

Both the count rate and correlation curve give a first impression about the quality of the measurements. Images acquired automatically during the FCS measurement series (with **Image after each \_\_ cycles, Figure 181**) can indicate movements of the specimen.

## 19 Summarized manual for FCS or other point measurements

### 19.1 Prerequisites

The following description assumes that the following prerequisites are met:

- SymPhoTime is started and a workspace is loaded.
- LAS AF was started.
- The right objective has been chosen and the correction ring adjusted to the specimen used (**Chapter 18.1.1** and **Chapter 18.1.4**).
- Your specimen is already placed onto the microscope and brought into focus. If you are measuring in solution, it is assumed that the laser is focused into the solution (see **Chapter 18.1.5**).
- The selected excitation lasers are switched on and activated (**Chapter 18.2.2** and **Chapter 18.3.2**).
- The correct emission filter(s) has/have been placed in your detector unit (**Chapter 23**).
- For beam splitter systems: The correct beam splitter for your wavelength has been selected in LAS AF.
- With AOB systems: The acousto-optical beam splitter is in fluorescence mode.

#### 19.1.1 Choosing the Location for the FCS Measurement

1. Start the FCS Wizard in LAS AF.
2. Scan an image. Also use the **Setup Imaging** step in the FCS Wizard.
3. Select the position at which you want to run a point measurement (**Chapter 18.2**).
4. Start the FCS test mode in LAS AF by selecting the image acquisition button **Run FCS Test** under the **Setup FCS** step in the FCS Wizard (**Chapter 18.3**).  
Normally, the SymPhoTime software will start the data acquisition automatically. However, you can also start the FCS data acquisition by selecting the **Acquire Point Measurements** button in the SymPhoTime software.

The **Measurement Preview** dialog in SymPhoTime opens on the **FCS** tab (**Figure 182**, left).

5. The display of the cross-trace and the two autocorrelation traces can be selected using the check boxes above the trace.
6. The update time can be set in the **Refresh** field. Together with the average count rate, the  $G(0)$  value and the molecular brightness (**Counts/Molec.**) are shown for the individual channels.

The molecular brightness is calculated by  $G(0)$  times the average count rate and displays the mean fluorescence count rate per dye molecule. The system is optimized (for example by adjusting the laser intensity and the objective collar) when maximum molecular brightness is attained.

In the **Time Trace** tab (**Figure 182**, right) the changes of the count rate over time can be observed. The binning (**resolution**) should be set to 1 ms.

- The settings in the **Measurement Preview** window in SymPhoTime can be preset by selecting **Show Measurement Preview...** when no measurement is running. Defaults can be saved using the **Set Defaults** button.
- The number of calculated points per trace can be adjusted with **Nsub**. The channel assignment is already preset, as shown in **Figure 182**. You should not change this assignment.

### 'Fifo overrun' error message



At very high count rates, depending on the computer power and number of calculated points per FCS trace, a **Fifo overrun** error can occur. In this case, use low Nsub values or switch off the FCS online correlation by unchecking the **FCS** check box under **Previews**.

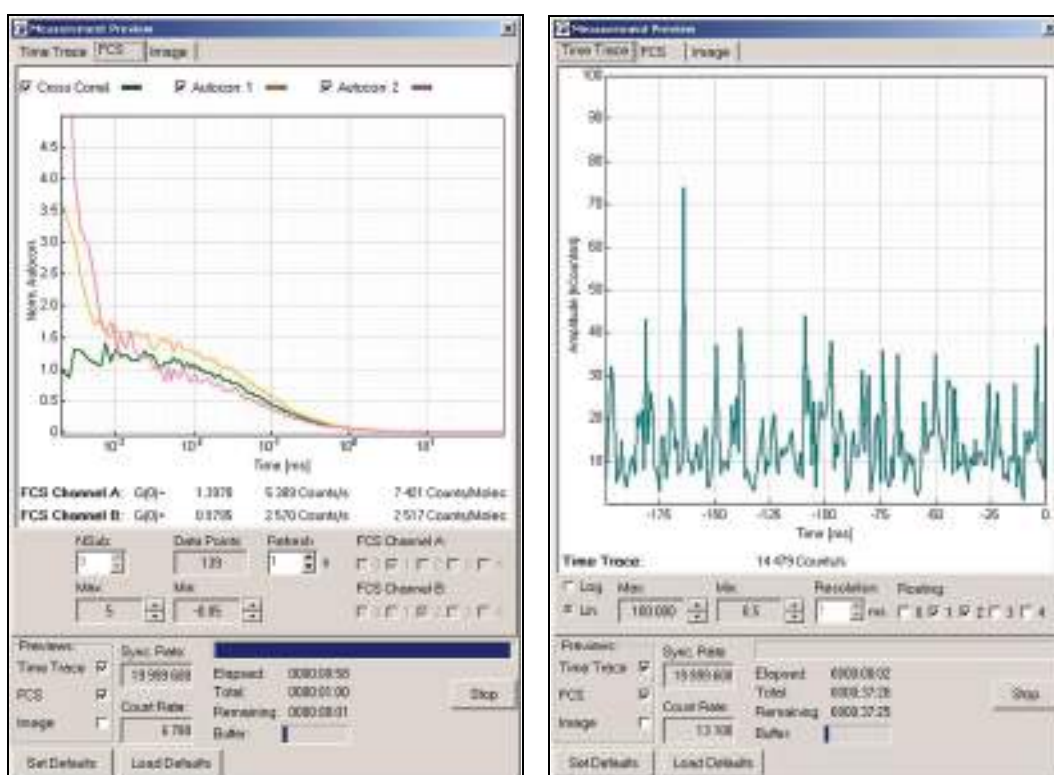

**Figure 182:** Online monitoring of the FCS trace and photon count rate in the SymPhoTime preview window. Left: FCS traces after 60 seconds of acquisition, cross and autocorrelation.  $G(0)$  near one corresponds to an average number of one dye molecule in the confocal detection volume. Right: Display of the count rate over time. The fluorescence bursts of single molecules are clearly visible.

## 19.2 Starting Point/ FCS Data Acquisition

- Start the FCS Wizard in LAS AF.
- Scan an image according to the **Setup Imaging** step (**Chapter 18.2**).
- Optimize the FCS settings in step **Setup FCS** (**Chapter 18.3** and **Chapter 19.1.1**).
- Go to the **Measurements** step (**Chapter 18.4**).
- Select the positions where you want to carry out a point measurement.

6. Select the measurement times.
7. Start the FCS measurement in LAS AF by selecting the image acquisition button **Run FCS** under the step **Measurements**.  
Normally, the SymPhoTime software will start the data acquisition automatically. If you start the FCS data acquisition by selecting **Acquire Point Measurements** in the SymPhoTime software, the measurement is not synchronized with LAS AF. The file name, comments and instrument parameter settings are not transferred from LAS AF to SymPhoTime.
8. The Measurement Preview dialog opens in SymPhoTime on the **FCS** tab (**Figure 182, left**). The FCS curve is integrated over time.



**Figure 183:** Working area of the annotation file

9. At the end of the measurement, the result can be viewed in the annotation file which can be opened from the workspace (**Figure 183**). Open the **Correlation** tab as shown in **Figure 184**. The curves can be analyzed by selecting the **FIT** button that corresponds to the cross-correlation or autocorrelation curve.
10. Starting from the acquired raw data file (in this case, **FCS 01.pt3**), the FCS curve can be recalculated with enhanced functions, such as Time Gated FCS or Fluorescence Lifetime Correlation Spectroscopy (FLCS) using the **FCS trace** button. The prerequisite for both of these modes is that the FCS measurement was carried out using pulsed lasers for excitation.

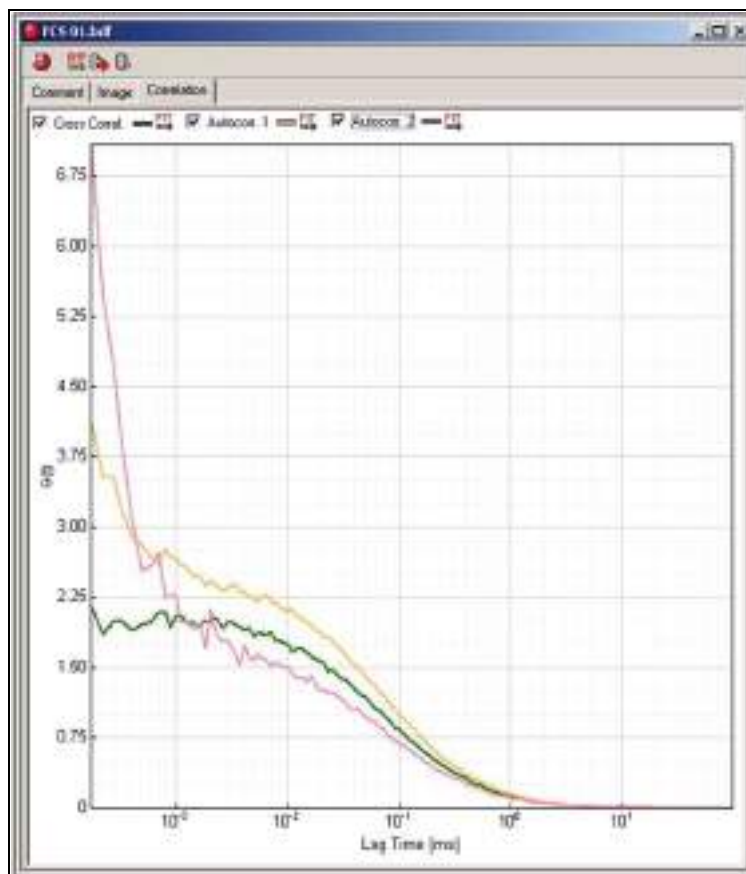

Figure 184: Display of the FCS curves in the "Correlation" tab of the annotation file

#### Using detectors with high quantum efficiency



FCS measurements can only be carried out with detectors with high quantum efficiency, such as APDs. Using cross-correlation between two detectors, **detector after pulsing** effects can be suppressed all the way to the correlation curve. With pulsed excitation, alternatively, FLCS can be used to calculate detector after-pulses for the individual detection channels from the raw data.



#### A stable count rate for FCS analysis is necessary

For a reliable FCS analysis, the count rate has to be stable. Signal attenuation due to photobleaching may lead to an increasing FCS correlation amplitude at long lag times.

## 20 Changing the Specimen

**WARNING** Risk of permanent eye damage from laser radiation



Never change specimens during the scanning operation because laser radiation can escape uncontrolled from the specimen area.

### 20.1 Changing the Specimen on an Upright Microscope

To change specimens on an upright microscope, proceed as follows:

1. Finish the scanning operation.
2. Ensure that no laser radiation exists in the specimen area.
3. Replace the specimen. Insert the specimen correctly into the specimen holder.
4. If you carry out FCS measurements, you have to reset the correction ring of the objective after every specimen change.

### 20.2 Changing the Specimen on an Inverted Microscope

To change specimens on an inverted microscope, proceed as follows:

1. Finish the scanning operation.
2. Ensure that no laser radiation exists in the specimen area.
3. Tilt the transmitted light arm back.
4. Replace the specimen. Insert the specimen correctly into the specimen holder.
5. Tilt the transmitted light arm back into the working position.
6. If you carry out FCS measurements, you have to reset the correction ring of the objective after every specimen change.



## 21 Changing the Objective

**WARNING Risk of permanent eye and skin damage from laser radiation**

Never change objectives during the scanning operation because laser radiation can escape uncontrolled from the specimen area.

To change objectives proceed as follows:

1. Finish the scanning operation.
2. Switch off the internal lasers using the detachable-key switch.
3. If any external lasers are present, switch them off with their detachable-key switch or as described in the laser manufacturer's user manual.
4. Rotate the objective nosepiece so that the objective to be changed is swiveled out of the beam path and points outward.
5. Exchange the objective.
6. Close all unoccupied positions in the objective nosepiece using the supplied caps. System operation with unlocked positions in the objective nosepiece is not allowed.

**WARNING Risk of permanent eye and skin damage from laser radiation**

All non-occupied positions in the objective nosepiece must be closed with the caps provided in order to prevent the uncontrolled escape of laser radiation in the specimen area.



## 22 Piezo Focus on Upright Microscope

If there is a piezo focus installed on your system (see **Figure 185**) pay careful attention to the following notes:

- Make sure that the specimen carrier is not against the objective and cannot be damaged by it or cause broken glass. The objective could likewise be damaged.
- Before switching the system on or launching the LAS AF software, ensure that there is no slide or specimen on the stage and that the specimen stage is in its lowest possible position. If this is not observed, specimens and objectives can be damaged or destroyed upon system/software startup by the initialization of the piezo focus.
- Do not carry out the objective change automatically. The automatic motion may damage the cable of the piezo focus.
- Do not make any adjustments to the piezo focus controller (see **Figure 186**), as it has already been optimally set up by Leica Service.
- When replacing the objective on the piezo focus, you must perform a teach-in for the new objective in LAS. Please see the instructions on this topic in the microscope operating manual.
- Please note that the focus position of an objective with piezo focus is 13 mm lower than those without piezo focus. In order to guarantee the same focal plane, a spacer is installed on all other objectives (see **Figure 187**).



**Figure 185:** Piezo focus on objective nosepiece

The objective can be moved by 150  $\mu\text{m}$  in either direction. The total travel is 300  $\mu\text{m}$ .

Piezo focus controller display:

- Highest position: 350  $\mu\text{m}$
- Middle position: 200  $\mu\text{m}$
- Lowest position: 50  $\mu\text{m}$
- xz scan range: 250  $\mu\text{m}$



**Figure 186:** Piezo focus controller



**Figure 187:** Spacer on objective

## 23 Changing the Filter Cube

### **WARNING** Risk of permanent eye damage from laser radiation



Never change filter cubes during the scanning operation because laser radiation can escape uncontrolled from the specimen area.

SMD filter cubes for the following dye combinations are available for the Leica SMD system:

Dye combination	Maximum number of external detection channels	Possible excitation lines	Beam splitter	Bandpass I	Bandpass II
neutral	2		50/50 %	-	-
Polarization	2		Polarization	-	-
GFP wide / RFP	2	458, 470, 488, 561, 594	LP 560	500 – 550	607 – 683
Alexa 488 / Alexa 633	2	458, 470, 488, 561, 594, 633	LP 620	500 – 550	647 – 703
CFP / YFP	2	405, 458, 514	LP 505	467 – 499	535 – 585
CFP/RFP	2	405, 458, 561, 594	LP 560	470 – 550	607 – 683
GFP narrow / RFP	2	458, 470, 488, 543, 561, 594	LP 560	500 – 530	607 – 683
GFP / RFP	2	458, 470, 488, 561, 594	LP 560	500 – 550	607 – 683
FITC/TRITC	2	458, 470, 488, 543	LP 560	500 – 550	565 – 605
GFP/HcRed	2	458, 470, 488, 561	LP 560	500 – 550	581 – 654
Alexa 405/ cy2	2	405, 470, 488	LP 470	418 – 458	500-550
DAPI, Atto 647	2	405, 514, 543, 561, 594, 633, 640	LP 620	420 – 500	650-710
Cy2/Cy5	2	470, 561, 633, 640	LP 620	485 – 550	650-710
CFP 440/YFP	2	405, 440, 514	LP 505	465-500	535-585
CFP 440/HcRed	2	405, 440, 514, 543, 561	LP 560	465-500	581-654
empty	1		-	-	-
VIS	1	405	-	-	LP 430
DAPI	1	405	-	-	420 - 500
FITC	1	405, 470, 488	-	-	500 - 550
TRITC	1	514, 543	-	-	565 - 605
Cy5	1	562, 594, 633	-	-	650 - 710

**Table 22:** List of available SMD filter cubes

Because the locking screws are accessible from the outside, the filter cubes can be replaced without removing the housing.

1. Abort the scanning operation.
2. Turn the key switch on the supply unit into the "OFF" position.
3. Switch off the APDs.
4. Detach the screws:



**Figure 188:** Adaptation at X1 port with SMD filter cube

5. Replace the filter cubes.
6. Retighten the locking screws.
7. Switch the APDs back on. It takes about 15 seconds until these are ready to operate. Do not carry out any scanning operation during that time.

Correct orientation and exact positioning of the filter cubes are assured by a locating pin arrangement of the retainer.

## 24 Changing Detector Cable Connections on the Scan Head and Router When Using HyD-RLD

If you have a Leica TCS SP8 SMD with MP configuration and external MPD APDs, internal SP FLIM PMT and HyD-RLDs, you can use the different detectors for different SMD experiments.



### Limitations when using HyD-RLDs

- APDs for FLCS and HyD-RLDs cannot be used simultaneously for confocal image acquisition
- SP FLIM PMTs and HyD-RLDs cannot be used simultaneously for FLIM experiments.

When using external MPD APDs and HyD-RLDs, there are two signals that are transferred over different cables: the image signal and the SMD signal. The SMD signal cable has to be connected with the PHR 800 router and the image signal cable with the connection of the APD printed circuit board on the scan head. When using multiple detectors, it is necessary that the detectors used are connected correctly with the PHR 800 router and the scan head's APD printed circuit board. For this purpose, changing the cable is necessary.

### NOTICE **Damage to the instrument when changing the cable connections is**

Switch all electronic components off before changing the cable connection, as otherwise the detectors or the scan head could become damaged. Also switch off the LAS AF, the scan head and the detectors.

The following detectors can be used and have to be connected correspondingly:

- **SP FLIM PMT:** The SMD signal cables have to be connected with CH 1 IN and CH 2 IN at the router's CFD input.
- **MPD APD (SPAD 1 and SPAD 2):** The image signal cable has to be connected at the APD printed circuit board of the scan head and the SMD signal cable has to be connected to CH 1 (detector channel 1) and CH 2 (detector channel 2) of the router.
- **HyD-RLD:** The image signal cable has to be connected at the APD printed circuit board of the scan head and the SMD signal cable has to be connected to CH 1 IN and CH 2 IN at the router's CFD input.

The following lasers can be used and have to be synchronized with the Pico Harp 300 counting unit:

- **MP (infrared laser):** The MP synchronization cable has to be connected to CH 0 of the counting unit.
- **White light laser** The white light laser synchronization cable has to be connected to the counting unit's CH 0.
- **Argon laser (if present):** The argon laser has no synchronization cable, therefore the MP or white light laser synchronization cable can remain connected with CH 0 of the counting unit.

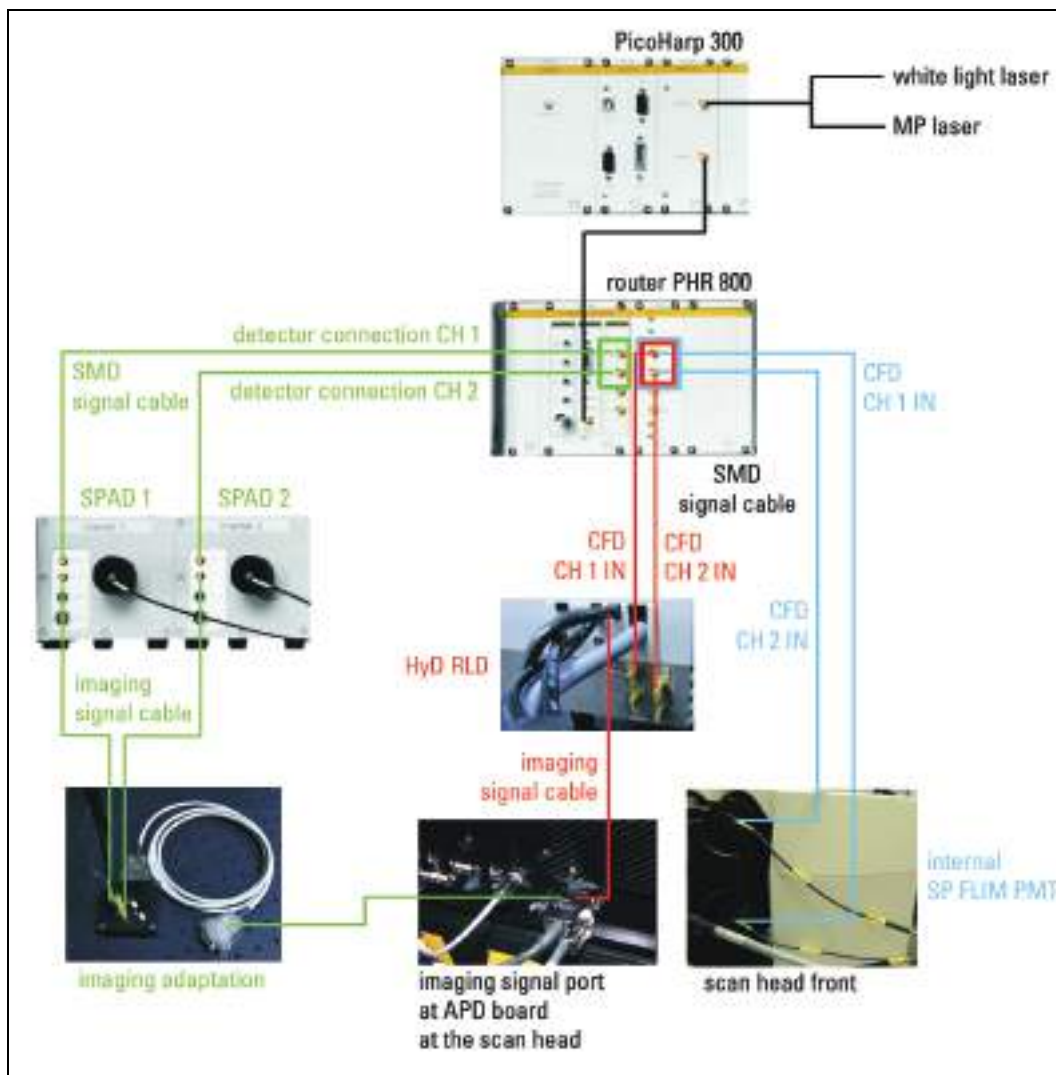

Figure 189: Overview of the terminals and cable connections

## 24.1 Hardware Trees

In order to enable all applications, your system is delivered with three different hardware trees: two for use of APDs and a third for use of HyD-RLDs. Select the correct hardware tree for the desired application when starting LAS AF:

- **MP on FCS FLIM 2 APD** (with use of SP-FLIM-PMTs and external APDs)
- **MP off FCS FLIM 2 APD** (with use of SP-FLIM-PMTs and external APDs)
- **MP on HyD RLD FLIM** (with use of HyD-RLD)

Depending on the hardware tree selected, various lasers and detectors are available to you which can be used for different applications. On the following page, you will find an overview of which applications are possible with the respective hardware configurations. The connections which must be created by the detector and the laser are on **Page 221**.

### 24.1.1 MP on FCS FLIM 2 APD

	SP FLIM PMT	MPD APD	HyD-RLD (no connection)
<b>MP laser</b>	Image acquisition, Descanned spectral MP FLIM	Image acquisition, Descanned MP FLIM	not possible
<b>White light laser</b>	Image acquisition, Spectral WLL FLIM	Image acquisition, WLL FLIM, WLL FCS, WLL FLCS	not possible
<b>Argon laser (if present)</b>	Image acquisition	Image acquisition, Continuous wave FCS	not possible

### 24.1.2 MP off FCS FLIM 2 APD

	SP FLIM PMT	MPD APD	HyD-RLD (no connection)
<b>White light laser</b>	Image acquisition, Spectral WLL FLIM	Image acquisition, WLL FLIM, WLL FCS, WLL FLCS	not possible
<b>Argon laser (if present)</b>	Image acquisition	Image acquisition Continuous wave FCS	not possible

### 24.1.3 MP on HyD RLD FLIM

	SP FLIM PMT	MPD APD (no connection between APDs and APD printed circuit board on the scan head)	HyD RLD
<b>MP laser</b>	Image acquisition, no FLIM (SMD signal cable is not connected)	Descanned MP FLIM, no image acquisition in LAS AF	Image acquisition, Non-descanned MP FLIM
<b>White light laser</b>	Image acquisition (SMD signal cable is not connected)	WLL FLIM, WLL FCS, WLL FLCS, no image acquisition in LAS AF	not possible
<b>Argon laser (if present)</b>	Image acquisition	Continuous wave FCS no image acquisition in LAS AF	not possible

## 24.2 Connect and Use Detectors

### 24.2.1 Using SP FLIM PMT

If you would like to use SP FLIM PMT, you have to connect the SMD signal cable of the detector in the scan head with the router. Proceed as follows:

1. Close the LAS AF software.
2. Switch the system, including the detectors, off.
3. Connect the SMD signal cable of the detector in the scan head (**Figure 192**) to the PHR 800 router's CFD inputs (**Figure 191**).
4. Connect the synchronization cable of the MP or white light laser with Channel 0 of the PicoHarp 300 counting unit (**Figure 197**). The connection between Channel 1 and the PHR 800 router can remain.
5. Switch the system, including the detectors, on.
6. Start the LAS AF software and select the hardware tree **MP on FCS FLIM 2 APD** or **MP off FCS FLIM 2 APD**.

### 24.2.2 Using MPD APDs

If you would like to use MPD APDs, you have to connect the image signal cable and the SMD signal cable of the detector with the scan head and router. Proceed as follows:

1. Close the LAS AF software.
2. Switch the system, including the detectors, off.
3. Connect the image signal cable of the MPD APDs (SPAD 1 and SPAD 2, **Figure 195**) to the signal converter (**Figure 196**). The cables can always stay attached to the signal converter.
4. Connect the signal converter to the APD printed circuit board of the scan head (**Figure 190**).
5. Connect the SMD signal cable MPD APDs (**Figure 195**) to the PHR 800 router's detector connections (**Figure 191**). These cables can always stay attached to the router.
6. Connect the synchronization cable of the MP or white light laser with Channel 0 of the PicoHarp 300 counting unit (**Figure 197**). The connection between Channel 1 and the PHR 800 router can remain.
7. Switch the system, including the detectors, on.
8. Start the LAS AF software and select the hardware tree **MP on FCS FLIM 2 APD** or **MP off FCS FLIM 2 APD**.

### 24.2.3 Using HyD-RLD

If you would like to use HyD RLD, you have to connect the detector's image signal cable and the SMD signal cable with the scan head and router. Proceed as follows:

1. Close the LAS AF software.
2. Switch the system, including the detectors, off.
3. Connect the HyD RLD image signal cable (**Figure 193**) to the scan head's APD printed circuit board (**Figure 190**).
4. Connect the HyD RLD SMD signal cable (**Figure 194**) to the PHR 800 router's CFD inputs.
5. Connect the MP laser's synchronization cable with Channel 0 of the PicoHarp 300 counting unit (**Figure 197**). The connection between Channel 1 and the PHR 800 router should remain in existence.
6. Switch the system, including the detectors, on.
7. Start the LAS AF software and select the **MP hardware tree on HyD RLD FLIM**.

The following figures show the hardware components with the relevant connections:



**Figure 190:** Connection for the image signal cable on the scan head's APD printed circuit board

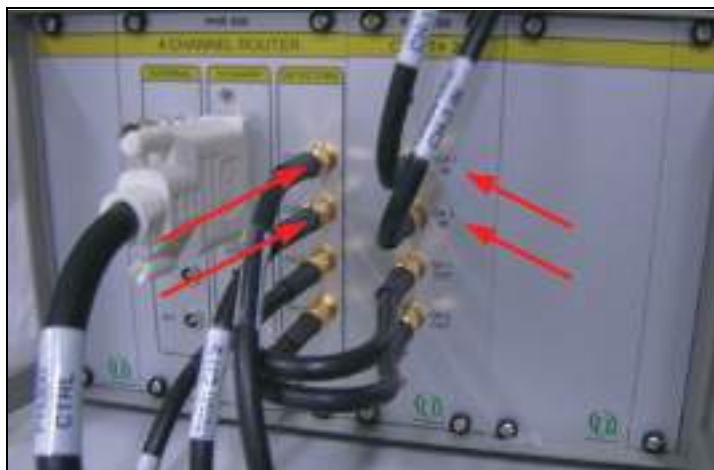

**Figure 191:** PHR 800 router: CH 1 and CH 2 (left) to connect the two SMD signal cables of the MPD APDs (SPAD 1 and SPAD 2) and CH 1 IN and CH 2 IN of the CFD input (right) to connect the SMD signal cable from SP FLIM PMTs or HyD RLDs

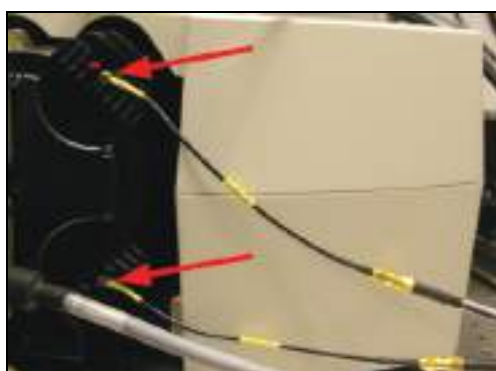

**Figure 192:** SMD signal cable on the scan head's internal SP FLIM PMTs



**Figure 193:** Image signal cable on the HyD RLD, which is attached to the scan head's APD printed circuit board

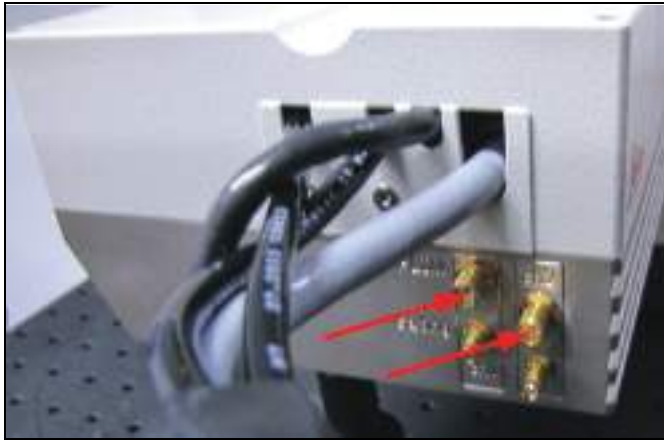

**Figure 194:** Terminals for the FLIM signal cable on HyD RLD, which are connected to the CFD input connector on the PHR 800 router

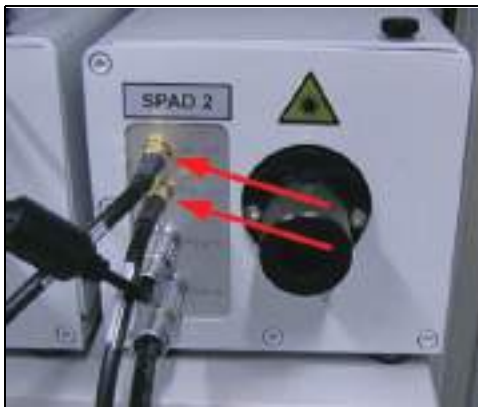

**Figure 195:** MPD APD (SPAD): The upper cable of each SPAD unit is connected to the PHR 800 router (see Figure 191, terminals left); the respective lower cable is connected with the signal converter (see Figure 196)



**Figure 196:** Signal converters to connect the image signal cable of the MPD APDs (SPAD 1 and SPAD 2) to the scan head's APD printed circuit board (see Figure 190)



**Figure 197:** PicoHarp 300 counting unit: At Channel 0, the synchronization cable of the laser used (MP laser or white light laser) is connected

## 25 Switching Off the System

The TCS SP8 SMD is available in different versions. You must precisely follow the switch-off sequence that applies to your system variant. During FLIM experiments, it is also possible to operate the system with a compact supply unit.

**NOTICE**    **Damage to the instrument when not adhering to the switch-off sequence**

The switch-off sequence must be followed! When not adhering to the below listed switch-off sequence, the laser can be damaged.

### 25.1 System with Flexible Supply Unit

1. Save the image data: To do so, click on the **Experiments** tab in LAS AF and click the **Save all** button.



Figure 198: Saving the image data in LAS AF

2. Close the LAS AF software: On the menu bar, select **File > Exit**.



Figure 199: Shutting down LAS AF

3. Save all relevant data in SymPhoTime and close the SymPhoTime software.
4. Turn off the lasers in the supply unit with the key switch on the main switch board of the flexible supply unit (see **Figure 200, item 4**).

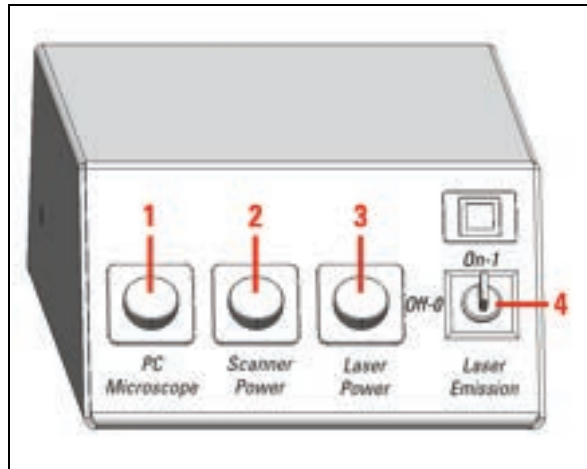

**Figure 200:** Overview of the main switch board on the flexible supply unit

The emission warning indicator goes out.

5. If you are using a DSN-102 power supply, switch off the detectors by pressing the channel buttons on DSN 102.
6. If you are using the PDL 828 Sepia II laser driver, set the key switch to the "OFF" position.
7. If your system has a white light laser, check whether the emission warning indicator lights. Should the emission warning indicator on the front side of the white light laser be lit, press the key below it. This causes all internal white light laser components to shut off and the emission warning indicator to go out.

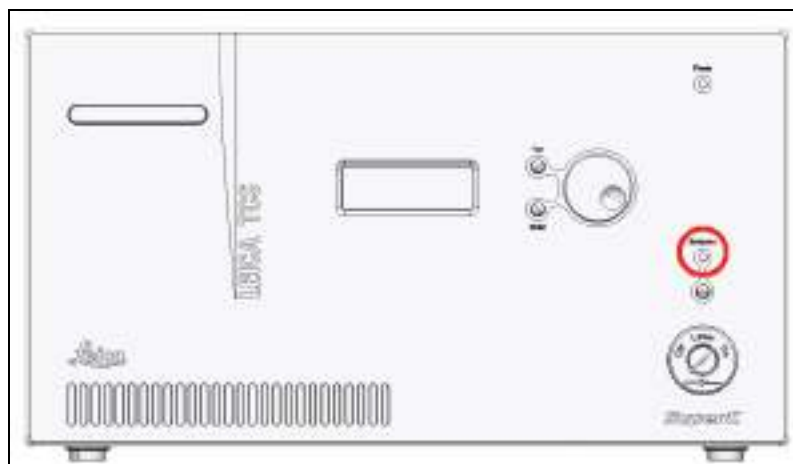

**Figure 201:** Emission Warning Indicator on the White Light Laser

8. Switch off the white light laser with the detachable-key switch on the front of the white light laser.

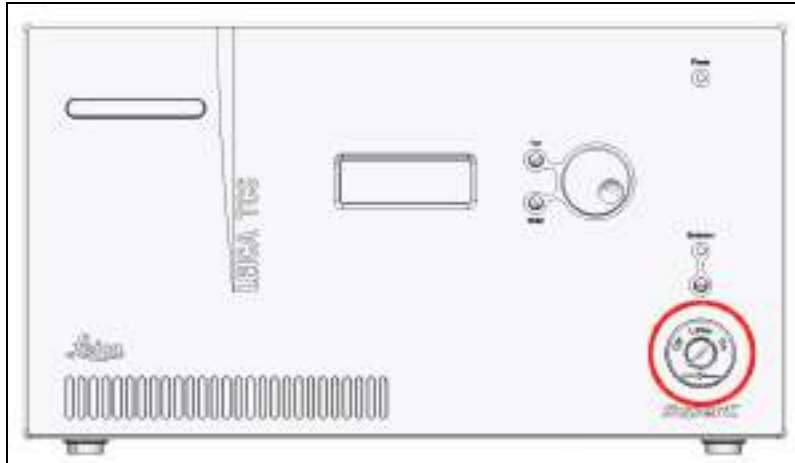

Figure 202: Key Switch for the White Light Laser

9. If you are using an external 355 and 405 (inclusive) UV laser, use the following key switch to turn it off (not possible for FLIM, FCS and FLCS images). The emission warning indicators go out.



Figure 203: Key switch on the power supply of external UV laser 355

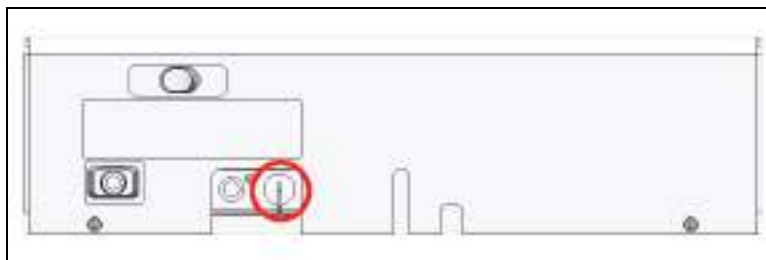

Figure 204: Key switch on external UV laser 405

10. Switch off both external UV laser main power switches 355 and 405.

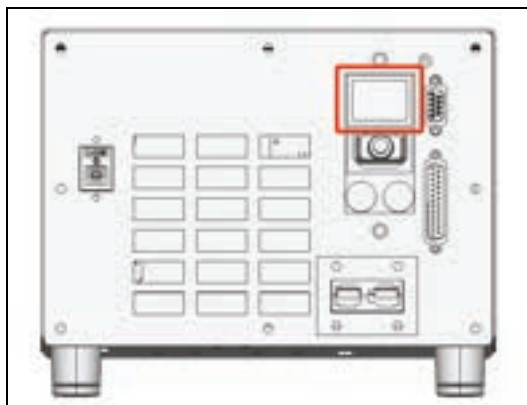

Figure 205: Power switch on external UV laser 355

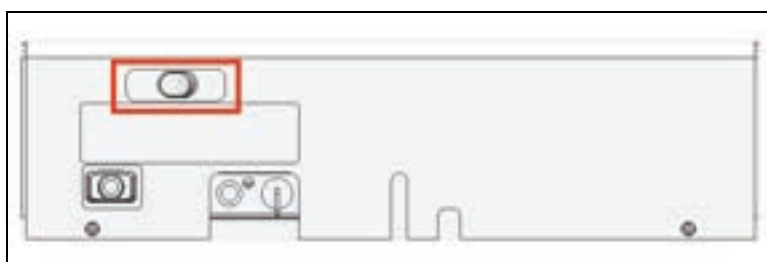

Figure 206: Power switch on external UV laser 405

11. If you are using a HyD RLD, switch it off at its supply unit:



Figure 207: HyD RLD supply unit

12. If your system is equipped with an NDD detection unit, switch it off:

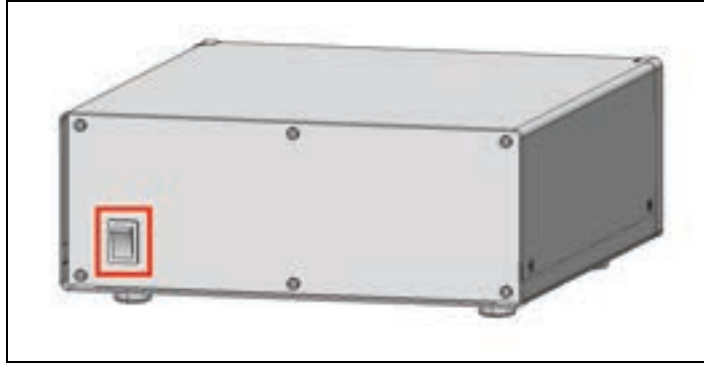

Figure 208: NDD detection unit

13. Shut down both workstations.
14. Switch off the lasers (see **Figure 200, item 3**), the scan head (see **Figure 200, item 2**), the workstation and the microscope (see **Figure 200, item 1**) on the flexible supply unit's main switch board.
15. Turn off any accessories being used.
16. Switch off the multiple socket outlet on the SMD trolley.



#### Observe the user manuals for external lasers

Please refer to the information from the documents provided by the laser manufacturer for the external lasers. Pay particular attention to the laser manufacturer's notes!

## 25.2 System with Compact Supply Unit (Only for FLIM)

1. Save the image data: To do so, click on the **Experiments** tab in LAS AF and click the **Save all** button.



Figure 209: Saving the image data in LAS AF

2. Close the LAS AF software: On the menu bar, select **File > Exit**.



Figure 210: Shutting down LAS AF

3. Save all relevant data in SymPhoTime and close the SymPhoTime software.
4. Turn off the lasers in the supply unit with the key switch on the front side of the compact supply unit (see **Figure 211, item 3**).

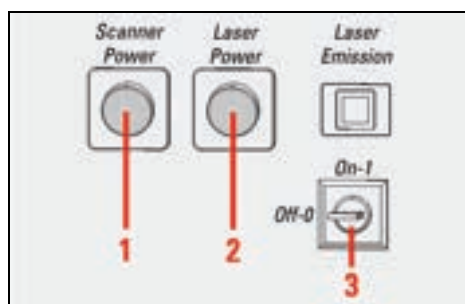

Figure 211: Overview of the Control Panel Field on the Compact Supply Unit

The emission warning indicator goes out.

5. If you are using a DSN102 power supply, switch off the detectors by pressing the channel buttons on DSN 102.
6. If you are using the PDL 828 Sepia II laser driver, set the key switch to the "OFF" position.
7. If you are using an external 355 and 405 (inclusive) UV laser, use the following key switch to turn it off (not possible for FLIM, FCS and FLCS images). The emission warning indicators go out.



Figure 212: Key switch on the power supply of external UV laser 355

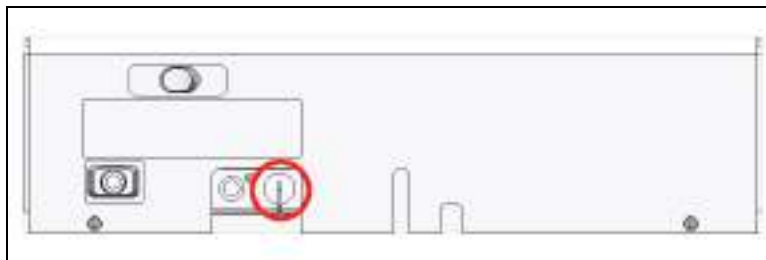

Figure 213: Key switch on external UV laser 405

8. Switch off both external UV laser main power switches 355 and 405.

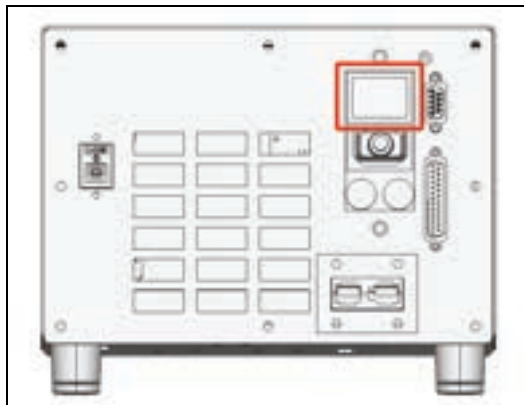

Figure 214: Power switch on external UV laser 355

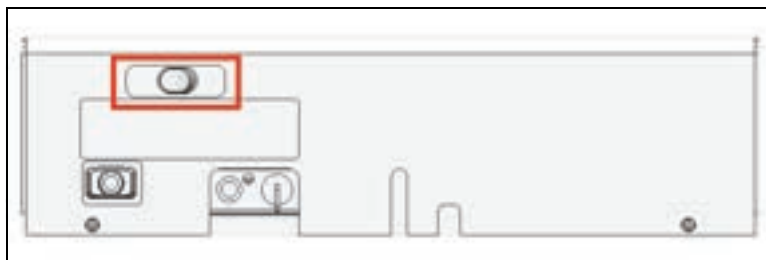

Figure 215: Power switch on external UV laser 405

9. If you are using a HyD RLD, switch it off at its supply unit:



Figure 216: HyD RLD supply unit

10. If your system is equipped with an NDD detection unit, switch it off:

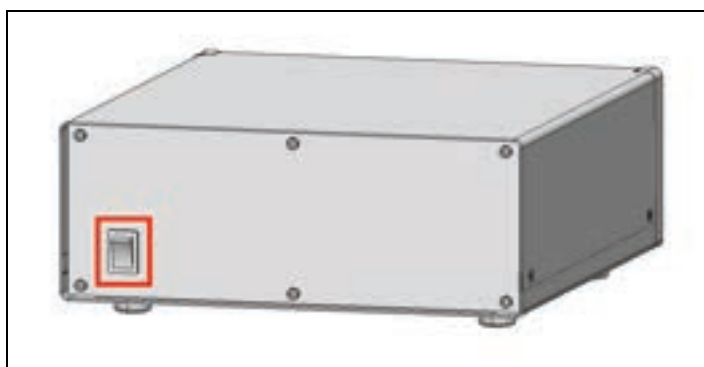

Figure 217: NDD detection unit

11. Shut down both workstations.

12. Switch off the lasers (see **Figure 211, item 2**) and the scan head (see **Figure 211, item 1**) on the front side of the compact supply unit.

13. Turn off the microscope by actuating the electronics box toggle switch (**Figure 218, item 2**). The readiness indicator (**Figure 218, item 1**) on the electronics box goes out.

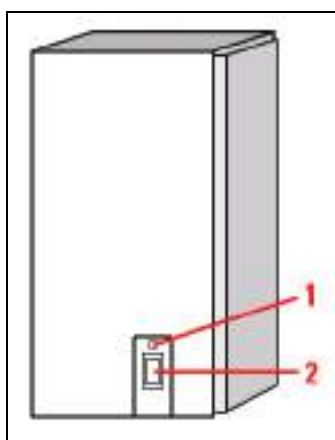

Figure 218: Microscope electronics box

14. Turn off any accessories being used.

15. Switch off the multiple socket outlet on the SMD trolley.



**Observe the user manuals for external lasers**

Please refer to the information from the documents provided by the laser manufacturer for the external lasers. Pay particular attention to the laser manufacturer's notes!



## 26 Care and Cleaning



### Observe the user manuals provided

Always observe all of the user manuals provided for the individual components and peripheral devices.

### WARNING

#### Electric shock



Before cleaning, disconnect the entire system from the power supply. To do so, use the power switches of all components and disconnect all power cables from the power supply.

Ensure that no fluids enter the individual components or peripheral devices during cleaning!

### 26.1 Cleaning Surfaces

- Never use abrasives. Abrasives can scratch the surface and thus have a negative effect on the protection of the parts.
- Remove dust and loose dirt particles using a soft brush or lint-free cotton cloth.
- You may clean uncoated or plastic surfaces only using a dry cotton cloth or one moistened with a little water. Other cleaning agents can attack and tarnish the surface and cause it to become porous.
- Carefully remove clinging dirt on coated surfaces using a clean cloth slightly moistened with water.
- Never use acetone, xylene or nitro thinners as they attack the varnish.

### 26.2 Cleaning the Optical System

- Never open the objectives for cleaning.
- Remove dust with a fine, dry brush made from hair or with a clean, lint-free cloth moistened with distilled water.
- Prevent the optics and mechanical parts from coming into direct contact with acids, bases and other aggressive chemicals.
- Remove persistent dirt from glass surfaces using pure alcohol or chloroform.

## 26.3 Cleaning Immersion Lenses

The immersion oil should be removed from oil immersion lenses immediately after it is applied:

1. First, remove the immersion oil using a clean cloth.
2. Once most of the oil has been removed with a clean tissue, a piece of lens tissue should be placed over the immersion end of the lens.
3. Apply a drop of the recommended solvent. Gently draw the tissue across the lens surface.
4. Repeat this procedure until the lens is completely clean. Use a clean piece of lens tissue each time.



### Caution when objective lens is contaminated

If an objective lens is contaminated by unsuitable immersion oil or by the specimen, please contact your local Leica branch office. Certain solvents may dissolve the glue which holds the lens in place.

## 26.4 Care

- Always keep the optical components of the microscope clean.
- Never touch the optical components with your fingers or anything which may bear dust or grease.
- Always place dust caps over the objective nosepiece positions when no objective is in place in the nosepiece.
- When not in use, cover the system with a plastic cover or a clean piece of cotton cloth.



### Avoid condensation

Allow the entire system to cool down to room temperature before covering the system with a dust cover. This prevents condensation from forming below it, which can enter the system and damage it.

## 27 Repairs and Service Work

### **WARNING** Contamination with hazardous substances



Before each call from a service technician, the system has to be cleaned thoroughly to avoid contamination with hazardous biological materials. When returning system parts, it must be ensured that they are free of hazardous substances - otherwise they must not be sent. This applies in particular to systems that are located in biomedical research labs.

- Repairs and servicing may be performed only by service technicians authorized by Leica Microsystems CMS GmbH. Opening or working on the system in any way shall void any and all warranty claims.
- If housing parts have to be opened for repairs or service work, only Leica service technicians may be present in the room where the system is installed.
- Be sure to back up your data before any service or repair work is performed. Leica Microsystems CMS GmbH shall not be liable for any loss of data.
- Inside the system there are installed components that can cause potentially fatal injury if handled improperly. Opening these components will result in danger to people and the system. Therefore, only authorized Leica service personnel may open or work on the supply unit and the scan head.



## 28 Maintenance

**NOTICE** **Damage to the instrument from not paying attention to the maintenance**  
Absolutely adhere to the prescribed maintenance intervals, as otherwise there can be serious damage to the instrument.

### 28.1 Having Coolant Replaced

The coolant (such as for scan head cooling and cooling the HyD RLD) must be replaced by Leica Service every two years.

You can find the safety data sheet for the coolant in the **Chapter "Appendix"**.

Maintenance and replacement of the coolant may only be carried out by service technicians who are authorized by Leica Microsystems CMS GmbH. Opening or working on the system in any way shall void any and all warranty claims.

**WARNING** **Contamination with hazardous substances**



Before each call from a service technician, the system has to be cleaned thoroughly to avoid contamination with hazardous biological materials. When returning system parts, it must be ensured that they are free of hazardous substances - otherwise they must not be sent. This applies in particular to systems that are located in biomedical research labs.



## 29 Disassembly and Transport

Do not disassemble system components or housing parts yourself. Opening or working on the system in any way shall void any and all warranty claims.

Contact the Leica branch office in your country or your contact person if you need to move or transport the system or need to ship parts of it.

### **WARNING** Contamination with hazardous substances



Before each call from a service technician, the system has to be cleaned thoroughly to avoid contamination with hazardous biological materials. When returning system parts, it must be ensured that they are free of hazardous substances - otherwise they must not be sent. This applies in particular to systems that are located in biomedical research labs.

Follow the notes provided in **Chapter "Repairs and Service Work"**.



## 30 Disposal

At the end of the product service life, please contact the Leica branch office in your country with regard to disposal.



### Disposal

The system, its accessory components and consumable materials must not be disposed of together with general household waste! Be sure to follow the national laws and regulations.



## 31 Troubleshooting

Make sure that all components of the TCS SP8 system as well as of the SMD upgrade are switched on.

### 31.1 Hardware Configuration Gets Lost or Software Needs to be Installed Again

The actual hardware configuration of your SMD upgrade (LSM trigger signal configuration, name of the TCSPC unit and corresponding settings, number of detection channels, etc.) is saved in a \*.cfg file. Restoring the configuration using the CFG file is also useful if you have to reinstall the software.

Select the **Restore from CFG file** menu item in the **Setup** menu (**Figure 219**). The original settings of the SMD upgrade are stored in the **Settings** folder in the SymPhoTime program directory and in the **MicroTime 200.cfg** file on the external USB memory stick included in the standard delivery of the instrument.



Figure 219: SymPhoTime menu for restoring the configuration settings

If the hardware equipment is changed, the CFG file needs to be changed accordingly to adapt the software to the hardware changes. Please contact Leica Microsystems CMS GmbH in this case. As the system is delivered already configured, it is not recommended to change settings without the supervision of Leica Microsystems CMS GmbH.

### 31.2 The Instrument Is Losing Sensitivity

- We recommend installing a power meter in the lab in order to measure the laser intensities for selected wavelengths. This is especially true for FCS measurements, since the laser power is a crucial parameter for FCS.
- If you have purchased an SMD upgrade with one or two APD detectors attached, the performance of the instrument can be checked using FCS traces of a dye solution with a dye that can be effectively excited. At a given laser intensity, filters and objective, and distance to the cover slip surface, the molecular brightness is a stable, characteristic value that can be used to monitor the instrument's performance. Suitable dyes for various wavelengths:

- ATTO655 for 640 nm
- Rhodamine 6G for 532 nm or fluorescein (in a solution with a high pH value)
- ATTO488 for 470-nm excitation
- The molecular brightness is the count rate of the detectors divided by the number of molecules present in the detection volume. It is displayed in the FCS preview. In general, a 10-nM solution is used. For a day-to-day comparison, use the same laser power, ideally controlled using a power meter. A more detailed description of FCS measurements is provided in the point measurement section.

### 31.2.1 Causes for Decreased Performance

If a performance drop is noticed, the origin of the performance drop needs to be determined first. A drop in system performance may be caused by:

- Decreasing laser power:  
Check the laser intensity with a laser power meter. If the laser power from PQ lasers is too low, either the laser coupling unit has to be readjusted or the laser needs to be repaired or replaced. In this case, please contact customer support.
- Decreasing detection sensitivity:
  - Misalignment of the TCS SP8: Contact Leica Service.
  - Misalignment of the fiber decoupler for the fluorescent light: Contact Leica Service.
  - Misalignment of the detector(s): In this case, please contact Leica customer support.

### 31.3 No FLIM Image is Displayed During Measurement

Can laser light be seen over the objective during measurement?

**If not:**

- Is the shutter open in LAS AF?
- Has the laser been activated by moving the corresponding slider?
- Is the multifunction port in the correct position?
- Is the pulse repetition rate of the pulsed lasers correct? This can be checked in the **Time Trace** preview window. When starting a measurement, at least background noise should be displayed (see **Figure 148** at the right in **Chapter 17.8**). If the repetition rate is equal to 0, check whether the SYNCHRONIZATION is set to external on the PDL800B or PDL800D and whether the laser emission lamp is illuminated during scanning.



#### Observe additional manuals

For more information, refer to the manual for the PDL800B or D.

**If yes:**

- Do you see a dark count rate when activating the **Time Trace** tab in the **Preview** window? If not, check to ensure that the detectors are still activated. The DSN 102 (if present) deactivates a detector automatically if the count rate exceeds a certain limit. In

this case, the detector must be switched on again on the DSN.

- Check whether the correct SMD filter cube emission filters are placed in the X1 port adapter. If you have a 2 MPD detector unit from PicoQuant, make sure that the beam splitter is set to the correct position.
- When all detectors are on and background counts are displayed in the oscillator window, place a fluorescent specimen in the Leica microscope, configure all the settings for FLIM in LAS AF and start the scanning operation while the time trace measurement is active in the **Preview** window. The count rate should increase. If the count rate does not increase, make sure that the shutters in front of the detectors are not closed (the filter should sit in the filter holder correctly). Shutters should click quietly when opening and closing.
- Make sure that the X1 port setting of the Leica TCS SP8 is correct. In LAS AF, select the following in the beam path window:
  - The --- position if you use external detectors
  - The **Mirror** position if you use internal SP FLIM detectors.
- If the shutter is not the problem, take a FLIM image as described in **Chapter 16.3**. Although no counts are displayed, a PT3 file is generated. Calculate a time trace from your FLIM \*.pt3 file, the same as if it were a point measurement, by choosing the **MCS Trace** button (only available if you have a software license for point analysis). The displayed time trace should contain the photon count. Select **marker 1 - 3** to show line start, line stop, and frame markers that are transferred from the instrument. You may have to select a suited display range in order to display the marker signals.

If there are no marker signals, check the cable connection between the Leica TCS SP8 and the SMD upgrade. If there are no marker signals even though the connection is intact, contact PicoQuant.

## 31.4 How to Handle PQ Error Codes in LAS AF

Error messages generated in SymPhoTime are also displayed in LAS AF. The following table provides a list of possible messages and recommended user actions.

PQ error code displayed in LAS AF	Recommended user action
PQ_ERRCODE_NO_ERROR	Continue
PQ_ERRCODE_MEASUREMENT_READY	Retry
PQ_ERRCODE_USER_BREAK	Measurement was stopped by user -> Retry
PQ_ERRCODE_MESSAGE_CORRUPTED = -1	Network communication problem -> Retry, report to Leica
PQ_ERRCODE_SERVER_BUSY = -2	Retry or restart system
PQ_ERRCODE_MESSAGE_TIMEOUT = -3	Retry
PQ_ERRCODE_INVALID_REC_VERSION = -10	SymPhoTime and LAS AF version incompatible -> Latest software versions installed?
PQ_ERRCODE_MEASUREMENT_TIMEOUT = -100	Retry
PQ_ERRCODE_FIFO_OVERRUN = -101	Count rates are too high -> Lower laser intensity
PQ_ERRCODE_DMA_ERROR = -102	Retry
PQ_ERRCODE_OSCILLOSCOPE_RUNNING = -103	Stop oscilloscope measurement in SymPhoTime
PQ_ERRCODE_HARDWARE_INIT = -104	Restart PicoHarp and SymPhoTime computer
PQ_ERRCODE_TTTR_INIT = -105	Restart PicoHarp and SymPhoTime computer
PQ_ERRCODE_TTTR_RUNNING = -106	Either another measurement is active -> Stop measurement in SymPhoTime or SymPhoTime is busy with saving data -> In an FCS or FLIM time series, increase the time between individual measurements
PQ_ERRCODE_NO_WORKSPACE = -107	Open workspace in SymPhoTime
PQ_ERRCODE_FILE_EXISTS = -108	Choose new file name in LAS AF that does not appear in the SymPhoTime workspace
PQ_ERRCODE_FILE_CREATE = -109	Folder is write-protected, choose other folder for workspace in SymPhoTime
PQ_ERRCODE_GROUPNAME_TOO_LONG = -110	Group name must be not longer than 63 characters -> Choose shorter base name in LAS AF
PQ_ERRCODE_FILENAME_TOO_LONG = -111	File name must be no longer than 255 characters -> Choose shorter base name in LAS AF
PQ_ERRCODE_TIMESTAMP_ARRAY_TOO_LONG = -112	Reduce frame size of FLIM image in x. Contact Leica
PQ_ERRCODE_INVALID_LICENSE = -999	The software license is not valid for this kind of measurement
PQ_ERRCODE_UNKNOWN_ERROR = -9999	Retry

**Table 23: SymPhoTime error codes displayed in LAS AF and recommended measures**

## **32      Contact**

If you have any further questions, please directly contact your country's Leica branch office or your local contact person. The appropriate contacts can be found on the Internet under:

<http://www.confocal-microscopy.com>



## 33 Recommended literature

Publications related to the LSM FLIM / FCS upgrade hardware, software, and underlying key technologies:

- Wahl M., Koberling F., Patting M., Rahn H., Erdmann R.: Time-resolved confocal fluorescence imaging and spectroscopy system with single molecule sensitivity and sub-micrometer resolution. *Current Pharmaceutical Biotechnology*, Ed. 05, S.299-308 (2004)
- Koberling F., Wahl M., Patting M., Rahn H.-J., Kapusta P., Erdmann R.: Two-channel fluorescence lifetime microscope with two colour laser excitation, single-molecule sensitivity, and submicrometer resolution. *Proceedings of SPIE*, 5143, p.181-192 (2003)
- Ortmann U., Dertinger T., Wahl M., Rahn H., Patting M., Erdmann R.: Compact TCSPC upgrade package for laser scanning microscopes based on 375 to 470 nm picosecond diode lasers *Proceedings of SPIE* 5325, S.179 (2004)
- Benda A., Hof. M., Wahl M., Patting M., Erdmann R., Kapusta P.: TCSPC upgrade of a confocal FCS microscope. *Review of Scientific Instruments*, Ed. 76, 033106 (2005)

Further literature can be found in the help menu of the SymPhoTime software.

The following application and technical notes are available from PicoQuant upon request:

- Koberling F., Schuler B.: FRET analysis of freely diffusing molecules using the MicroTime 200
- Krämer B., Koberling F.: Lifetime based hydrophobicity analysis of hepatocytes using the MicroTime 200
- Krämer B., Koberling F., Tannert A., Korte T., Hermann A.: Lifetime based analysis of lipid organization in hepatocytes using the MicroTime 200
- Ortmann U., Dertinger T., Wahl M., Bültner A., Erdmann R., Kahl H.: Compact FLIM and FCS upgrade kit for Olympus FV 300 and FV 1000 laser scanning microscopes
- Wahl M.: Time-correlated single photon counting in fluorescence lifetime analysis
- Wahl M.: Time tagged time resolved fluorescence data collection

Numerous measurement examples are published on the PicoQuant website. Visit the LSM FLIM / FCS Upgrade section on the following website:

[http://www.picoquant.com/\\_systems.htm](http://www.picoquant.com/_systems.htm)



## 34 Abbreviations

AOBS	Acousto-optical beam splitter
AOTF	Acousto-optical tunable filter
APD	Avalanche Photo Diode
AQR	Product description of the APD by Perkin Elmer
BNC	British Naval Connector or Bayonet Nut Connector or Bayonet Neill Concelman
CCD	Charge-Coupled Device
CFD	Constant Fraction Discriminator
cps	Counts per second
cw	Continuous wave (not pulsed)
DSN	Product name of the Dual SPAD Power Supply
EOM	Electro-optical modulator
FCCS	Fluorescence Cross-Correlation Spectroscopy
FCS	Fluorescence Correlation Spectroscopy
LCU	Laser Coupling Unit
FIFO	First In, First Out (buffer type)
FLIM	Fluorescence Lifetime Imaging
FRET	Förster Resonance Energy Transfer
FWHM	Full Width at Half Maximum
IO	Input-Output
IPS	Instrument Parameter Setting
IRF	Instrument Response Function
LAS AF	Leica Application Suite Advanced Fluorescence
LED	Light Emitting Diode
LSM	Laser Scanning Microscope
MCS	Multichannel Scaling
MPD	Micro Photon Devices (manufacturer of the SPADs)
NDD	Non-descanned detector
OD	Optical Density
PC	Personal Computer
PCI	Peripheral Component Interface
PDL	Product name for PQ Pulsed Laser Drivers
PE	Perkin Elmer
PIE	Pulsed Interleaved Excitation
PMT	Photomultiplier Tube
RGB	Red-Green-Blue (color scheme)
ROI	Region of Interest
SHG	Second Harmonic Generation
SMA	SubMiniature version A (connector type)
SMD	Single Molecule Detection
SPAD	Single Photon Avalanche Diode

SPT	SymPhoTime (software from PicoQuant)
SYNC	Synchronization (signal)
TCSPC	Time-Correlated Single Photon Counting
TTL	Transistor-Transistor Logic
TTR	Time-Tagged Time-Resolved

## **35 Appendix**

### **35.1 Patents**

The Leica TCS SP8 product is protected by US patents:

5,886,784; 5,903,688; 6,137,627; 6,222,961; 6,285,019; 6,311,574; 6,355,919; 6,423,960; 6,433,814; 6,444,971; 6,466,381; 6,510,001; 6,614,031; 6,614,525; 6,614,526; 6,654,165; 6,657,187; 6,677,579; 6,678,443; 6,687,035; 6,738,190; 6,754,003; 6,771,405; 6,801,359; 6,831,780; 6,850,358; 6,852,964; 6,867,899; 7,016,101.

Further patents are pending.

The Leica TCS SP8 X product is protected by US patents:

5,886,784; 5,903,688; 6,137,627; 6,222,961; 6,285,019; 6,311,574; 6,355,919; 6,423,960; 6,433,814; 6,444,971; 6,466,381; 6,510,001; 6,611,643; 6,614,031; 6,614,525; 6,614,526; 6,654,165; 6,657,187; 6,677,579; 6,678,443; 6,687,035; 6,710,918; 6,738,190; 6,754,003; 6,771,405; 6,796,699; 6,801,359; 6,831,780; 6,850,358; 6,852,964; 6,867,899; 6,888,674; 6,898,367; 6,958,858; 7,016,101; 7,110,645; 7,123,408; 7,257,289; 7,679,822

Further patents are pending.

### **35.2 Safety Data Sheets from Third-Party Manufacturers**

The scan head is liquid-cooled. Following are the safety data sheets from the manufacturer "Innovatek" for the coolant used.

EEC - SAFETY DATA SHEET  
Gem. 91/155/EG; 2001/58/EG



Dated:  
February 28st 2011 / innovatek Protect application mixture

innovatek OS GmbH  
[www.innovatek.de](http://www.innovatek.de)  
[info@innovatek.de](mailto:info@innovatek.de)

### 1. Substance/preparation and company name

Trade name: innovatekProtect IP – application mixture  
company: innovatek OS GmbH, Stadtweg 9, 85134 Stammham  
Tel: 08405/92590  
Fax: 08405/925921  
Emergency phone No.: +49 (0) 8405/92590

### 2. Composition / information on ingredients

Chemical nature:	Ethylene glycol (ethane diol). Corrosion inhibitors.	
Hazardous Compounds:		
Ethandiol	Content (w/w): >25% +-5%	CAS No: 107-21-1
	EC No: 203-473-3	Hazard symbol: Xn
	INDEX No: 603-027-00-1	R-phrases: 22
2-ethylhexanoic acid, sodium salt	Content (w/w): 0,5 % - 0,75 %	CAS No: 19766-89-3
	EC No: 243-283-8	Hazard symbol: Xn
		R-phrases: 63

The wording of the hazard symbols and R-phrases is specified in Chapter 16 if dangerous ingredients are mentioned.

### 3. Hazard identification

Special risks for people and environment: Damages caused to someone's health by swallowing.

### 4. First aid measures

General advice:	Remove contaminated clothing.
If inhaled:	If difficulties occur after vapour/aerosol has been inhaled: fresh air, summon physician.
On skin contact:	Wash thoroughly with soap and water.
On contact with eyes:	Wash affected eyes for at least 15 minutes under running water with eyelids held open.
On ingestion:	Rinse mouth immediately and then drink plenty of water, seek medical attention.
Note to physician:	Symptomatic treatment (decontamination, vital functions). Administer 50 ml of pure ethanol in a drinkable concentration.

### 5. Fire fighting measures

Suitable extinguishing media:	Water spray, alcohol-resistant foam, dry extinguishers, carbon dioxide (CO <sub>2</sub> ).
Special protective equipment:	In case of fire, wear a self contained breathing apparatus.
Further information:	The degree of risk is governed by the burning substance and the fire conditions. Contaminated extinguishing water must be disposed of in accordance with local legislation.

Figure 220: innovatek Protect application mixture safety data sheet page 1

EEC - SAFETY DATA SHEET  
Gem. 91/155/EG; 2001/58/EG



Dated:  
February 28st 2011 / innovatek Protect application mixture

innovatek OS GmbH  
[www.innovatek.de](http://www.innovatek.de)  
[info@innovatek.de](mailto:info@innovatek.de)

## 6. Accidental release measures

Personal precautions:	Avoid excessive contact with skin and eyes. In case of release of larger amounts remove contaminated clothing and wash body down thoroughly with water. Hand protection. Pick up immediately as product renders floors slippery.
Environmental precautions:	Contain contaminated water/firefighting water. Do not discharge product into natural waters without pretreatment (biological treatment plant).
Methods for cleaning up / taking up:	Bind the liquid by using suitable absorbent material (saw dust, sand, etc.) and dispose of in accordance with the regulations. Wash away spills thoroughly with large quantities of water. In case of release of larger quantities which might flow into the draining system or waters, contact appropriate authorities.

## 7. Handling and storage

Handling:	Ensure thorough ventilation of stores and work areas.
Protection against fire and explosion:	Take precautionary measures against static discharges. If exposed to fire, keep containers cool by spraying with water.
Storage:	Product is hygroscopic. Containers should be stored tightly sealed in a dry place. Storage in galvanized containers is not recommended.

## 8. Exposure controls and personal protection

Components with workplace control parameters: 107-21-1: Ethylene glycol	MAK value (D): 26 mg/m <sup>3</sup> = 10 ppm (TRGS 900 (DE)). Top limit category 1. There is no reason to fear a risk of damage to the developing embryo when the MAK value is adhered to. Skin resorption hazard: wear suitable gloves (see below).
Personal protective equipment	
Respiratory Protection:	Do not inhale gases/vapours/aerosols.
Hand protection:	Chemical resistant protective gloves (EN 374). Recommended: nitrile rubber, protective index 6. Manufacturers directions for use should be observed because of great diversity of types.
Eye protection:	Safety glasses with side-shields (frame goggles, EN 166)
General safety and hygiene measures:	The usual precautions for the handling of chemicals must be observed.

## 9. Physical and chemical properties

Form:	Liquid
Colour:	Colourless
Odour:	Product specific
pH value ( 500 g/l, 20 °C):	7.0 - 9.0
Solidification temperature:	< -10 °C (DIN/ISO 3016)
Boiling point/range:	>= 105 °C (ASTM D 1120)
Flash point:	>120 °C (only valid für the Ethylenglykol part)(DIN/ISO 2592)
Lower explosion limit:	3.0 % vol. (only valid für the Ethylenglykol – part)

Figure 221: innovatek Protect application mixture safety data sheet page 2

<p>EEC - SAFETY DATA SHEET Gem. 91/155/EG; 2001/58/EG</p>		
<p>Dated: February 28st 2011 / innovatek Protect application mixture</p>		<p>innovatek OS GmbH <a href="http://www.innovatek.de">www.innovatek.de</a> <a href="mailto:info@innovatek.de">info@innovatek.de</a></p>
Upper explosion limit:	15.0 % vol (only valid für the Ethylenglykol – part)	
Ignition point:	>200°C (DIN 51794)(only valid für the Ethylenglykol – part)	
Vapor pressure (20°C):	2 mbar (DIN 51757)	
Density (20°C):	ca. 1.04 g/cm <sup>3</sup>	
Miscibility with water:	optional mixable	
Solubility (quantitative) solvent:	polar solvents: soluble	
Viscosity (kinematic, 20°C):	3-5 mm <sup>2</sup> /s	
<b>10. Stability and reactivity</b>		
Substances to avoid:	Strong oxidizing agents.	
Hazardous reactions:	No hazardous reactions when stored and handled according to instructions.	
Hazardous decomposition products:	No hazardous decomposition products if stored and handled as prescribed/indicated.	
<b>11. Toxicological data</b>		
LD50/oral/rat:	>2000 mg/kg (only valid für the Ethylenglykol – part)	
LD50/dermal/rabbit:	non- irritant (only valid für the Ethylenglykol – part)	
Primary skin irritation/rabbit/:	non-irritant	
Information on Ethylene glycol:		
Further information:	Developmental toxicity was observed after oral ingestion of high doses in studies with rats and mice, but this effect was not seen in a study with rabbits.	
Experiences in humans:	Lethal dose if swallowed approx. 1.5 g/kg body weight. Lethal dose approx. 90-110 g for adults, and correspondingly less for children. Smaller doses can result in: consciousness is affected, kidney damage, damage to the central nervous system.	
Additional information:	The statements are based on the properties of the individual components. There is no reason to fear a risk of damage to the developing embryo or fetus when the MAK value is adhered to. The whole of the information available provides no indication of a carcinogenic effect.	
<b>12. Ecological information</b>		
Ecotoxicity:	<p>Toxicity to fish: <i>Leuciscus idus</i>/LC50 (96 h): &gt;400 mg/l          Aquatic invertebrates: <i>daphnia magna</i>/EC50 (48 h): &gt;400 mg/l          Aquatic plants: algae/EC50 (72 h): &gt;400 mg/l          Microorganisms/Effect on activated sludge: Inhibition of degradation activity in activated sludge is not to be anticipated during correct introduction of low concentrations.</p>	
Persistence and Degradability:	<p>Elimination information:          Test method: OECD 301A (new version)          Method of analysis: DOC reduction          Degree of elimination: &gt;70 %          Evaluation: readily biodegradable.</p>	
Additional information:	Other ecotoxicological advice: Do not release untreated into na-	

Figure 222: innovatek Protect application mixture safety data sheet page 3

EEC - SAFETY DATA SHEET  
Gem. 91/155/EG; 2001/58/EG



Dated:  
February 28st 2011 / innovatek Protect application mixture

innovatek OS GmbH  
[www.innovatek.de](http://www.innovatek.de)  
[info@innovatek.de](mailto:info@innovatek.de)

tural waters. The product has not been tested. The statement was derived from the properties of the individual components.

### 13. Disposal considerations

innovatekProtect must be dumped or incinerated in accordance with local regulations.

Contaminated packaging:

Uncontaminated packs can be reused. Packs that cannot be cleaned should be disposed of in the same manner as the contents.

### 14. Transport information

Not dangerous according to transport regulations (ADR RID ADNR IMDG / GGVSee ICAO / IATA)

### 15. Regulatory information

Regulations of the European union (Labelling) / National legislation / Regulations: Directive 1999/45/EEC („Preparation Directive“)

Hazard Symbol:	Xn:	Harmful
R-phrases:	22:	Harmful if swallowed
S-phrases:	2:	Keep out of reach of children
	24/25:	Avoid contact with skin and eyes
	46:	If swallowed, seek medical advice immediately and show this container or label

Hazard determinant component

for labelling:

1,2-Ethanediol

Other regulations:

Classification according to VbF (Germany): None  
Categorization according to TA-Air (Germany)3.1.7  
Category III  
Water compromises category (attachment 4 of VwVwS(Germany) from 17.Mai 1999): (1) low water compromising

### 16. Further Information

Full text of hazard symbols and R-phrases if mentioned as hazardous components in chapter 2:

Xn: Harmful

22: Harmful if swallowed.

63: Possible risk of harm to the unborn child.

Vertical lines in the left hand margin indicate an amendment from the previous version.

This safety data sheet is intended to provide information and recommendations as to: 1. how to handle chemical substances and preparations in accordance with the essential requirements of safety precautions and physical, toxicological, and ecological data. 2. how to handle, store, use, and transport them safely.

No liability for damage occurred in connection with the use of this information or with the use, application, adaption, or processing of the products here described will be accepted. An exception will be made in the case that our legal representatives should come to be held re-

Figure 223: innovatek Protect application mixture safety data sheet page 4

EEC - SAFETY DATA SHEET  
Gem. 91/155/EG; 2001/58/EG



Dated:  
February 28st 2011 / innovatek Protect application mixture

innovatek OS GmbH  
[www.innovatek.de](http://www.innovatek.de)  
[info@innovatek.de](mailto:info@innovatek.de)

sponsible and liable by reason of intent or gross negligence. No liability will be accepted for damage indirectly incurred.

We provide this information and data according to our present level of knowledge and experience. No assurances concerning the characteristics of our product are hereby furnished.

Figure 224: innovatek Protect application mixture safety data sheet page 5

### 35.3 Compliance

This system has been tested and meets the requirements of the following standards:

IEC/EN 61010-1:2011	"Safety requirements for electrical equipment for measurement, control and laboratory use - Part 1: General requirements"
IEC/EN 60825-1:2007	"Safety of laser products - Part 1: Equipment classifications and requirements"
IEC/EN 61326-1:2006	"Electrical equipment for measurement, control and laboratory use - EMC requirements - Part 1: General requirements (class A)"  This is a Class A instrument for use in buildings that do not include domestic premises and buildings not directly connected to a low-voltage power supply network that supplies buildings used for domestic purposes.

You can find the Declaration of Conformity for the system on the following page of this User Manual.

#### For use in the USA:

CDRH 21 CFR 1040.10:	Laser Products U.S. Food and Drug Administration (FDA) "Complies with FDA performance standards for laser products except for deviations pursuant to laser notice No. 50, dated June 24, 2007".
----------------------	---

For the USA (area of validity of the CDRH/FDA), the designations of the laser class are to be changed in the text from 3B to IIIb and Class 4 to IV.



**EC Declaration of Conformity**  
No.: CE 137-01

**Manufacturer:** Leica Microsystems CMS GmbH

**Address:** Am Friedensplatz 3  
68165 Mannheim, Germany

**Product:** **Confocal Laser Scanning Microscope**  
**TCS SP8 product family and accessories**  
**TCS SP8 X product family and accessories**

We declare that the product described herein complies with the following European Directives:

2004/108/EC Directive on Electromagnetic compatibility  
2006/95/EC Directive on Low-voltage equipment

The product conforms to the standards:

EN 61326-1:2006  
Electrical equipment for measurement, control and laboratory use -  
EMC requirements – Part 1: General requirements  
Emission Class A

EN 61010-1: 2010  
Safety requirements for electrical equipment for measurement,  
control and laboratory use - Part 1: General requirements

EN 60825-1: 2007  
Safety of laser products  
Part 1: Equipment classification and requirements

For the microscope models DM and DMI the respective EC Declaration of Conformity with its corresponding EC Directives is valid.

This declaration shall cease to be valid if modifications are made to the product without our approval.

Mannheim, Germany  
May 30, 2012

  
.....  
i.V. Steffen Laabs  
Head of RA/QA

Figure 225: Declaration of conformity

## 35.4 People's Republic of China

- Administrative Measures on the Control of Pollution Caused by Electronic Information Products -

部件名称 Name of the part	有毒有害物质或元素 Hazardous substances					
	铅 (Pb)	汞 (Hg)	镉 (Cd)	六价铬 (Cr <sup>6+</sup> )	多溴联苯 (PBB)	多溴二苯醚 (PBDE)
印刷电路板 printed circuit boards	X	O	O	O	O	O
电子元器件 electronic components	X	O	O	O	O	O
机械部件 mechanical parts	X	O	O	X	O	O
光学元器件 optical components	X	O	X	O	O	O
电缆 cables	O	O	O	O	X	X
光源 light sources	X	X	X	O	O	O

- o : 表示该有毒有害物质在该部件中的含量均在SJ/T 11363-2006标准规定的限量要求以下。  
Indicates that the concentration of the hazardous substance in all materials in the parts is below the relevant threshold of the SJ/T 11363-2006 standard.
- x : 表示该有毒有害物质至少在该部件的某一材料中的含量超出SJ/T 11363-2006标准规定的限量要求。  
Indicates that the concentration of the hazardous substance of at least one of all materials in the parts is above the relevant threshold of the SJ/T 11363-2006 standard.

Note: The actual product may or may not include all the part types listed above.





www.leica-microsystems.com



Leica Microsystems CMS GmbH  
Am Friedensplatz 3  
D-68165 Mannheim (Germany)

Phone: +49 621 7028 - 0  
Fax: +49 621 7028 - 1028  
<http://www.leica-microsystems.com>

Copyright © Leica Microsystems CMS GmbH • All rights reserved

User Manual Leica TCS SP8 SMD  
Order number: 158000062 | V: 00